

KLM / KLP / DKLM / DKLP

ELECTRIC IN-LINE PUMPS



TECHNICAL DATA

Operating range:

from 2 to 67 m³/h with head up to 13,7 metres.

Pumped liquid: clean, free of solids and abrasives, non-viscous, non-aggressive, non-crystallised and chemically neutral, with properties similar to water. Maximum glycol content 30 % (for other glycol percentages contact Technical Support).

Pumped liquid temperature range: from -15 °C to +120 °C.

Maximum ambient temperature: +40°C.

Maximum operating pressure: 10 bar (1000 kPa).

Standard flanges:

DN 40, DN 50, DN 65, DN 80 - PN 6/PN 10 (4 holes).

Flanges on request: DN 80 - PN 16 (8 holes).

Counter flanges on request:

threaded DN 40, DN 50, DN 65 in PN 10.

welded DN 40, DN 50, DN 65, in PN 10/PN 16 (4 holes).

welded DN 80 in PN 10/PN 16 (8 holes)

Special executions on requests: alternative voltages and frequencies.

APPLICATIONS

Hot or cold water circulation pump with in-line ports, suitable for installation directly on the pipework of civil and industrial heating, air conditioning, refrigeration, and sanitary water systems.

CONSTRUCTION FEATURES OF THE PUMP

Pump body and motor support in cast iron.

PN 10 flanged suction and delivery ports with threaded holes for control manometers. To make replacement in existing systems easier, the pump can accept PN 6 counter flanges.

Technopolymer impeller.

Carbon/ceramic mechanical seal.

The pumps are available both in the single (KLM-KLP) and in the twin (DKLM-DKLP) versions.

For the single version a built in clapet valve in the delivery port is also included, to avoid water recirculation when the unit is idle. A blind flange is also supplied as a standard, to be used during maintenance of one of the two motors.

The twin version gives the possibility of alternating the operation of the pumps when a backup unit is required, or to have the two pumps operating simultaneously.

CONSTRUCTION FEATURES OF THE MOTOR

External ventilation cooling, closed, asynchronous type, with four poles for the KLM and DKLM versions, and two poles for the KLP and DKLP versions.

Rotor running on permanently lubricated ball bearings, oversized to ensure low noise and durability.

Standard built-in thermo-amperometric protection. Capacitor permanently fitted on single phase versions.

For the protection of the three-phase motor, we recommend the use of remote overload cut-outs, in compliance with current local regulations.

Construction according to CEI 2-3.

Protection class: IP 55

Insulation class: F

Standard voltage: single-phase 220-240 V, 50 Hz.
 three-phase 230/400 V, 50 Hz

MATERIALS

N.	PARTS*	MATERIALS
1	PUMP BODY	CAST IRON 250 UNI ISO 185
3	SUPPORT	CAST IRON 250 UNI ISO 185
4	IMPELLER	TECHNOPOLYMER B
7	SHAFT WITH ROTOR	AISI 303 STAINLESS STEEL X10 CrNiS 1809 UNI 6900/71
16	MECHANICAL SEAL	CARBON / CERAMIC
26	OR RING	EPDM RUBBER

* In contact with the liquid

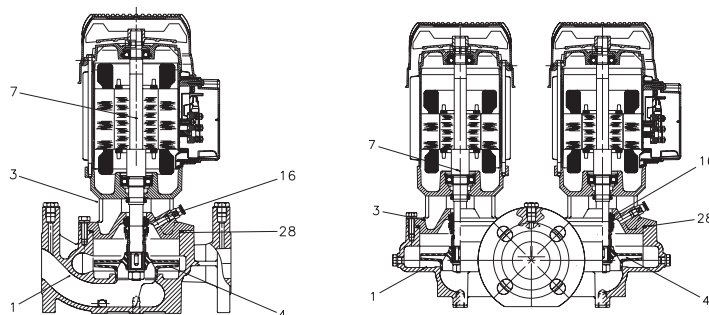

KLM / KLP / DKLM / DKLP

ELECTRIC IN-LINE PUMPS

– Denomination index:
(example)

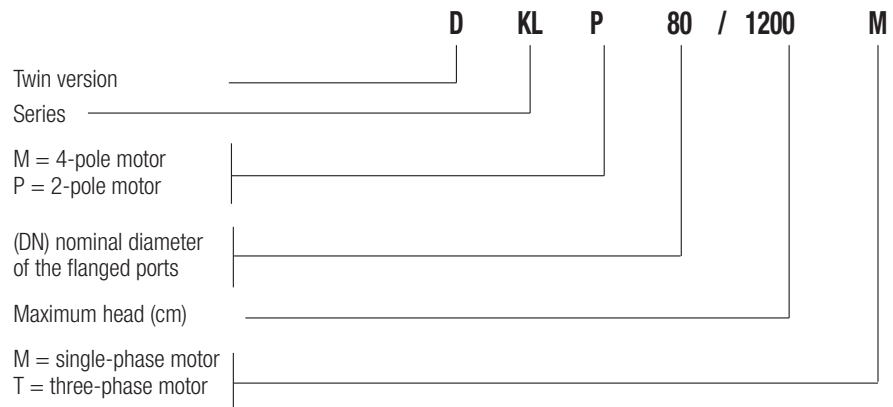

Installation: horizontal or vertical position, provided that the motor is always above the pump.

KLM / KLP

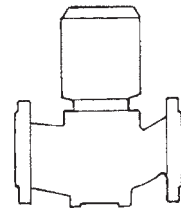
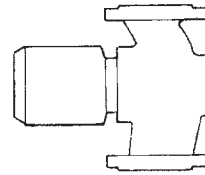

DKLM / DKLP

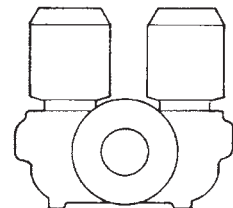
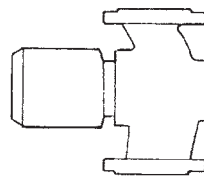
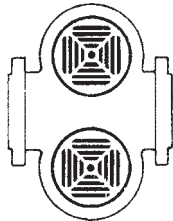
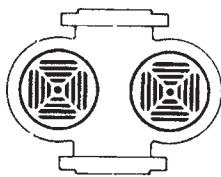

ELECTRIC IN-LINE PUMPS

IN-LINE ELECTRIC PUMPS FOR CIRCULATION SYSTEMS

PERFORMANCE RANGE

The performance curves are based on kinematic viscosity values = 1 mm²/s and density equal to 1000 kg/m³. Curve tolerance according to ISO 9906.

GRAPHIC SELECTION TABLE

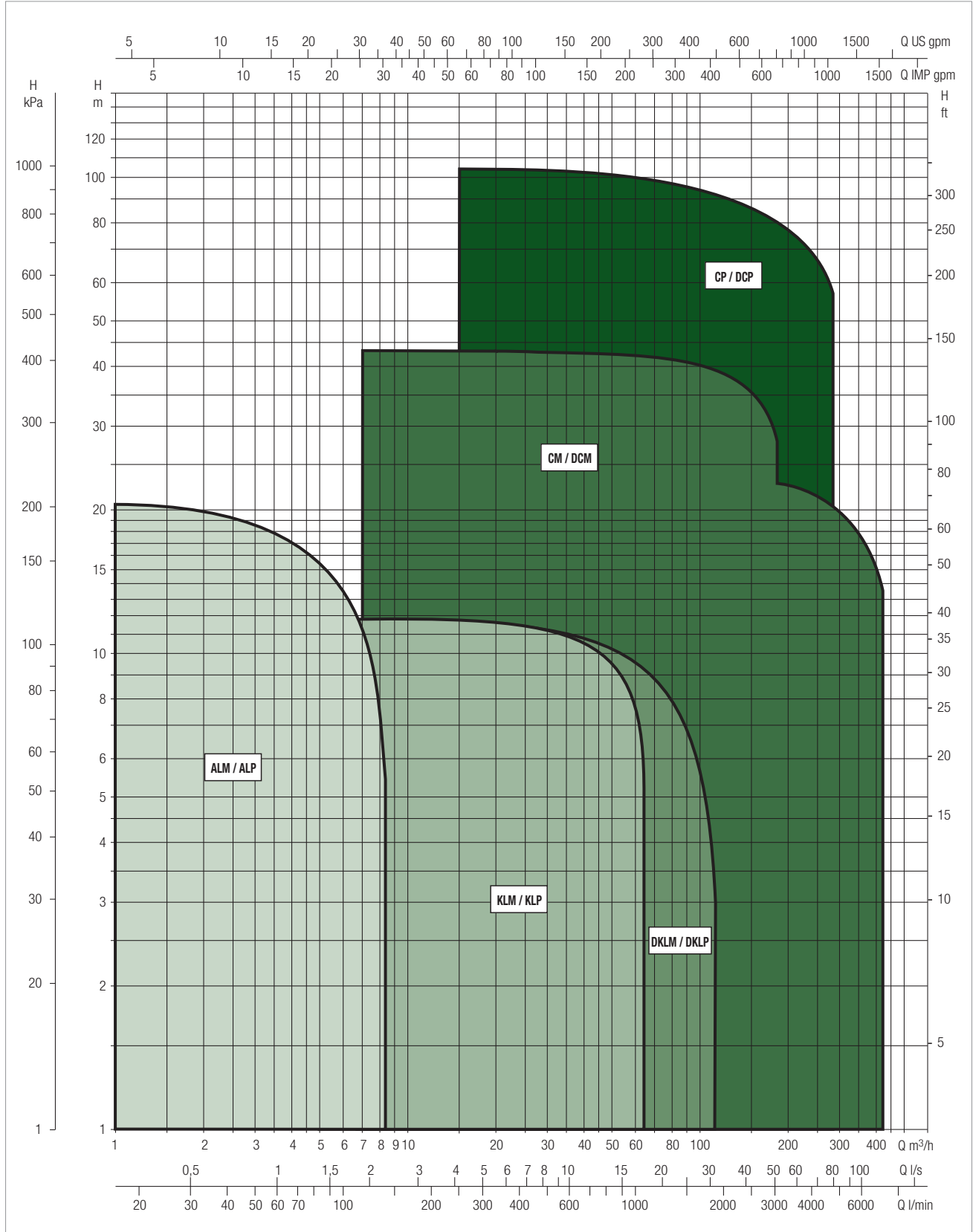

IN-LINE PUMPS

KLM / KLP / DKLM / DKLP

ELECTRIC IN-LINE PUMPS

SELECTION TABLE - KLM / KLP

MODEL	Q=m ³ /h	0	2,4	3,6	4,8	6	7,2	8,4	9,6	12	14,4	16,8	18	24	30	36	48	60
	Q=l/min	0	40	60	80	100	120	140	160	200	240	280	300	400	500	600	800	1000
KLM 40-300 M	H (m)	3,4	3,2	3	2,6	2,3	1,7											
KLM 40-300 T		3,4	3,2	3	2,6	2,3	1,7											
KLP 40-600 M		8,2			7,8	7,4	6,9	6,3	5,7	4								
KLP 40-600 T		8,2			7,8	7,4	6,9	6,3	5,7	4								
KLP 40-900 M		10,2			9,8	9,4	8,8	8,2	7,4	5,6								
KLP 40-900 T		10,2			9,8	9,4	8,8	8,2	7,4	5,6								
KLP 40-1200 M		13,7			13,2	12,6	11,9	11,2	10,4	8,4	5,9							
KLP 40-1200 T		13,7			13,2	12,6	11,9	11,2	10,4	8,4	5,9							

MODEL	Q=m ³ /h	0	2,4	3,6	4,8	6	7,2	8,4	9,6	12	14,4	16,8	18	24	30	36	48	60
	Q=l/min	0	40	60	80	100	120	140	160	200	240	280	300	400	500	600	800	1000
KLM 50-300 M	H (m)	2,9			2,8	2,7	2,6	2,5	2,3	1,8	1,3							
KLM 50-300 T		2,9			2,8	2,7	2,6	2,5	2,3	1,8	1,3							
KLM 50-600 M		5,4			5,2	4,9	4,7	4,5	4,3	3,8	3,2	2,5	2					
KLM 50-600 T		5,4			5,2	4,9	4,7	4,5	4,3	3,8	3,2	2,5	2					
KLP 50-900 M		8,9				8,8	8,7	8,6	8,5	8	7,4	6,6	6,3	3,9				
KLP 50-900 T		8,9				8,8	8,7	8,6	8,5	8	7,4	6,6	6,3	3,9				
KLP 50-1200 M		12				12	11,8	11,6	11	10,5	9,8	9	8,6	6,2				
KLP 50-1200 T		12				12	11,8	11,6	11	10,5	9,8	9	8,6	6,2				

MODEL	Q=m ³ /h	0	2,4	3,6	4,8	6	7,2	8,4	9,6	12	14,4	16,8	18	24	30	36	48	60
	Q=l/min	0	40	60	80	100	120	140	160	200	240	280	300	400	500	600	800	1000
KLM 65-300 T	H (m)	3,1				3	2,9	2,8	2,7	2,6	2,4	2	1,8					
KLM 65-600 T		5,5						5,3	5	4,7	4,6	4	3,8	2,5				
KLP 65-900 T		9							8,8	8,6	8,5	8,1	8	7	5,5	3,5		
KLP 65-1200 T		12									11,6	11,4	11,2	11	10	8,8	6,7	

MODEL	Q=m ³ /h	0	2,4	3,6	4,8	6	7,2	8,4	9,6	12	14,4	16,8	18	24	30	36	48	60
	Q=l/min	0	40	60	80	100	120	140	160	200	240	280	300	400	500	600	800	1000
KLM 80-300 T	H (m)	3,3								3,2	3,1	3	2,9	2,7	2	1,2		
KLM 80-600 T		5,7									5,8	5,8	5,7	5,5	5	4,3	2,5	
KLP 80-900 T		8,8									8,7	8,6	8,5	8,4	8	7,7	6	
KLP 80-1200 T		11,8													11,6	11,5	11	9,7

KLM / KLP / DKLM / DKLP

ELECTRIC IN-LINE PUMPS

SELECTION TABLE - DKLM / DKLP

MODEL	Q=m ³ /h	0	2,4	3,6	4,8	6	7,2	8,4	9,6	12	14,4	16,8	18	24	30	36	48	60
	Q=l/min	0	40	60	80	100	120	140	160	200	240	280	300	400	500	600	800	1000
DKLM 40-300 M	H (m)	3,4	3,2	3	2,6	2,3	1,7											
DKLM 40-300 T		3,4	3,2	3	2,6	2,3	1,7											
DKLP 40-600 M		8,2			7,8	7,4	6,9	6,3	5,7	4								
DKLP 40-600 T		8,2			7,8	7,4	6,9	6,3	5,7	4								
DKLP 40-900 M		10,2			9,8	9,4	8,8	8,2	7,4	5,6								
DKLP 40-900 T		10,2			9,8	9,4	8,8	8,2	7,4	5,6								
DKLP 40-1200 M		13,7			13,2	12,6	11,9	11,2	10,4	8,4	5,9							
DKLP 40-1200 T		13,7			13,2	12,6	11,9	11,2	10,4	8,4	5,9							

MODEL	Q=m ³ /h	0	2,4	3,6	4,8	6	7,2	8,4	9,6	12	14,4	16,8	18	24	30	36	48	60
	Q=l/min	0	40	60	80	100	120	140	160	200	240	280	300	400	500	600	800	1000
DKLM 50-300 M	H (m)	2,9			2,8	2,7	2,6	2,5	2,3	1,8	1,3							
DKLM 50-300 T		2,9			2,8	2,7	2,6	2,5	2,3	1,8	1,3							
DKLM 50-600 M		5,4			5,2	4,9	4,7	4,5	4,3	3,8	3,2	2,5	2					
DKLM 50-600 T		5,4			5,2	4,9	4,7	4,5	4,3	3,8	3,2	2,5	2					
DKLP 50-900 M		8,9				8,8	8,7	8,6	8,5	8	7,4	6,6	6,3	3,9				
DKLP 50-900 T		8,9				8,8	8,7	8,6	8,5	8	7,4	6,6	6,3	3,9				
DKLP 50-1200 M		12				12	11,8	11,6	11	10,5	9,8	9	8,6	6,2				
DKLP 50-1200 T		12				12	11,8	11,6	11	10,5	9,8	9	8,6	6,2				

MODEL	Q=m ³ /h	0	2,4	3,6	4,8	6	7,2	8,4	9,6	12	14,4	16,8	18	24	30	36	48	60
	Q=l/min	0	40	60	80	100	120	140	160	200	240	280	300	400	500	600	800	1000
DKLM 65-300 T	H (m)	3,1				3	2,9	2,8	2,7	2,6	2,4	2	1,8					
DKLM 65-600 T		5,5						5,3	5	4,7	4,6	4	3,8	2,5				
DKLP 65-900 T		9							8,8	8,6	8,5	8,1	8	7	5,5	3,5		
DKLP 65-1200 T		12									11,6	11,4	11,2	11	10	8,8	6,7	

MODEL	Q=m ³ /h	0	2,4	3,6	4,8	6	7,2	8,4	9,6	12	14,4	16,8	18	24	30	36	48	60	
	Q=l/min	0	40	60	80	100	120	140	160	200	240	280	300	400	500	600	800	1000	
DKLM 80-300 T	H (m)	3,3								3,2	3,1	3	2,9	2,7	2	1,2			
DKLM 80-600 T		5,7									5,8	5,8	5,7	5,5	5	4,3	2,5		
DKLP 80-900 T		8,8										8,7	8,6	8,5	8,4	8	7,7	6	
DKLP 80-1200 T		11,8													11,6	11,5	11	9,7	7,2

DKLM / DKLP40 - IN-LINE ELECTRIC PUMPS FOR HEATING, AIR CONDITIONING, REFRIGERATION, SOLAR, AND SANITARY SYSTEMS - SINGLE, FLANGED

Pumped liquid temperature range: from -15 °C to +120 °C - Maximum ambient temperature: +40 °C

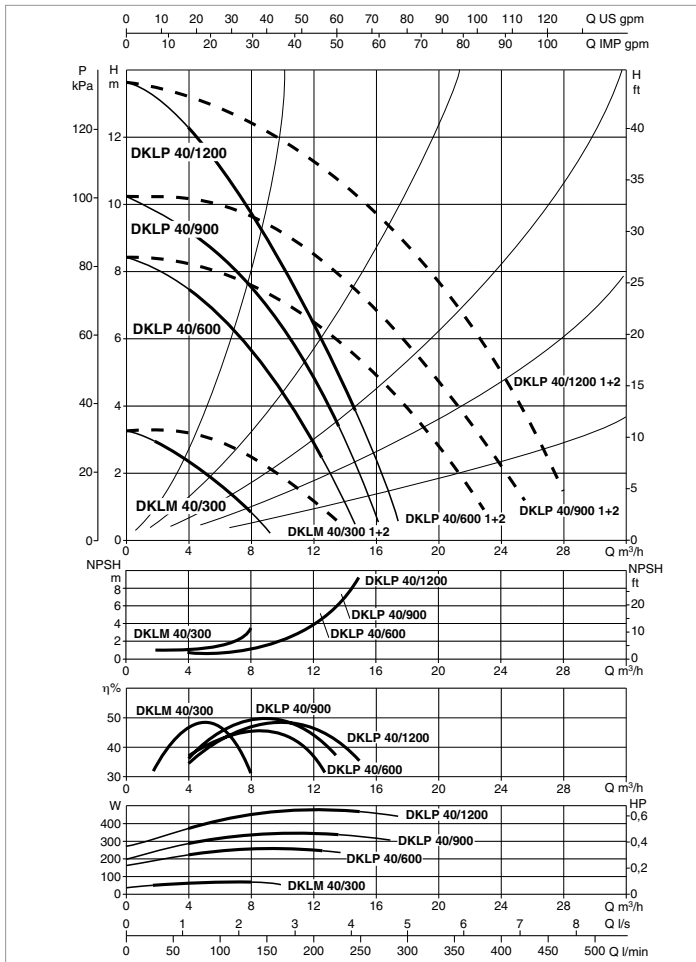
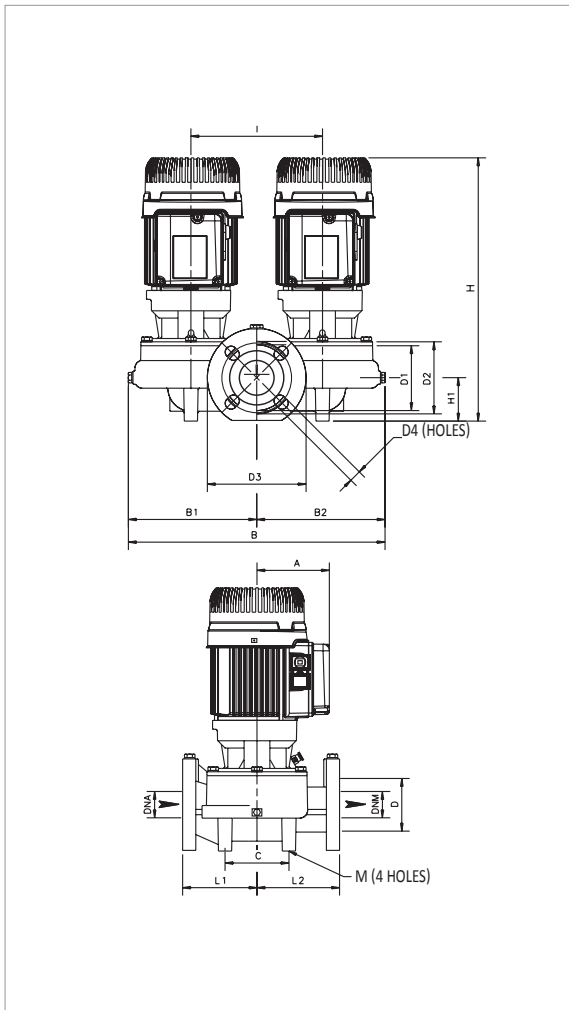

The performance curves are based on kinematic viscosity values = 1 mm²/s and density equal to 1000 kg/m³. Curve tolerance according to ISO 9906.

For the MEI index refer to the hydraulic data of the individual pump.

MODEL	CENTRE DISTANCE	PUMP CONNECTIONS	ELECTRICAL DATA								CAPACITOR	
			POWER INPUT 50 Hz	MOTOR TYPE	n r.p.m.	P1 MAX W	P2 NOMINAL		In A	μF	Vc	
							kW	HP				
DKLM 40-300 M	250	DN 40	1 x 230 V ~	4 POLES	1450	0,17	0,25	0,33	1	8	450	
DKLM 40-300 T	250	DN 40	3 x 230 - 400 V ~	4 POLES	1450	0,14	0,25	0,33	0.9-0.55	-	-	
DKLP 40-600 M	250	DN 40	1 x 230 V ~	2 POLES	2940	0,47	0,37	0,5	3	20	450	
DKLP 40-600 T	250	DN 40	3 x 230 - 400 V ~	2 POLES	2950	0,39	0,37	0,5	1.7-1	-	-	
DKLP 40-900 M	250	DN 40	1 x 230 V ~	2 POLES	2920	0,54	0,37	0,5	3,2	20	450	
DKLP 40-900 T	250	DN 40	3 x 230 - 400 V ~	2 POLES	2920	0,45	0,37	0,5	1.9-1.1	-	-	
DKLP 40-1200 M	250	DN 40	1 x 230 V ~	2 POLES	2890	0,7	0,55	0,75	3,4	20	450	
DKLP 40-1200 T	250	DN 40	3 x 230 - 400 V ~	2 POLES	2890	0,6	0,55	0,75	2-1.2	-	-	

MODEL	A	B	B1	B2	C	DNA	DNM	D	D1	D2	D3	D4	H	H1	I	L	L1	L2	M	PACKING DIMENSIONS			VOLUME (m ³)	WEIGHT kg
																				L/A	L/B	H		
DKLM 40/300	110	372	185	187	100	40	40	80	100	110	150	4 HOLES 18x23	400	55	200	250	125	125	4 HOLES 10	530	280	470	0,07	38,2
DKLP 40/600	110	372	185	187	100	40	40	80	100	110	150		400	55	200	250	125	125		530	280	470	0,07	41,8
DKLP 40/900	110	372	185	187	100	40	40	80	100	110	150		400	55	200	250	125	125		530	280	470	0,07	41,8
DKLP 40/1200	110	372	185	187	100	40	40	80	100	110	150		400	55	200	250	125	125		530	280	470	0,07	41,8

DKLM / DKLP 50 - IN-LINE ELECTRIC PUMPS FOR HEATING, AIR CONDITIONING, REFRIGERATION, SOLAR, AND SANITARY SYSTEMS - SINGLE, FLANGED

Pumped liquid temperature range: from -15 °C to +120 °C - Maximum ambient temperature: +40 °C

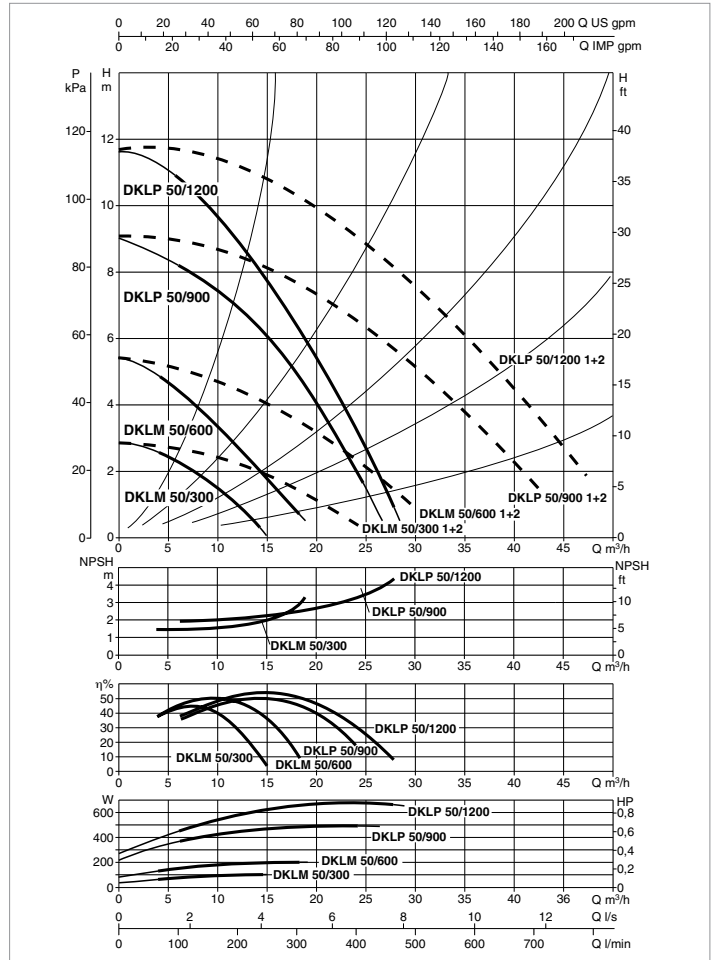
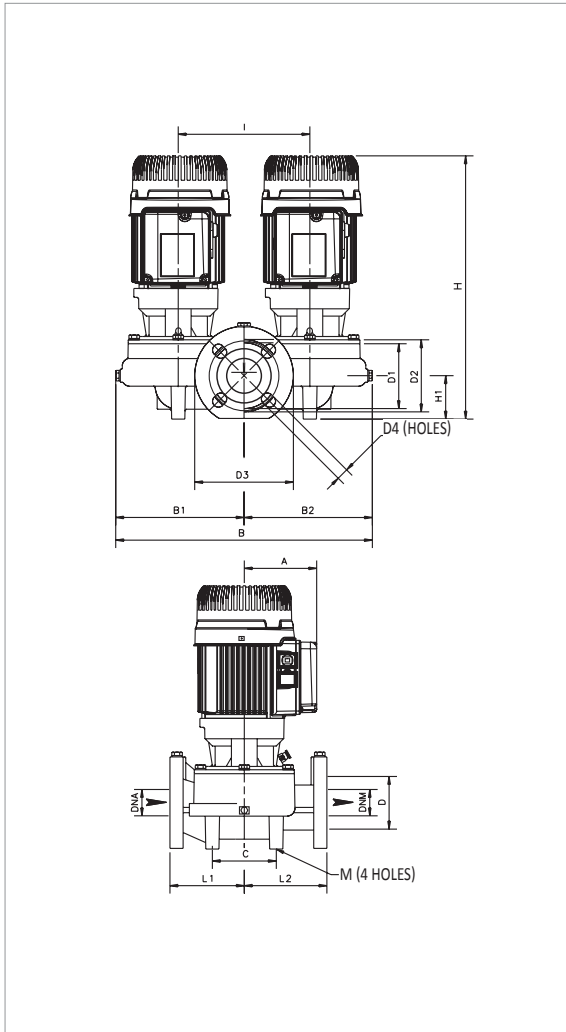

The performance curves are based on kinematic viscosity values = 1 mm²/s and density equal to 1000 kg/m³. Curve tolerance according to ISO 9906.

For the MEI index refer to the hydraulic data of the individual pump.

MODEL	CENTRE DISTANCE	PUMP CONNECTIONS	ELECTRICAL DATA								
			POWER INPUT 50 Hz	MOTOR TYPE	n r.p.m.	P1 MAX W	P2 NOMINAL		In A	CAPACITOR	
							kW	HP		µF	Vc
DKLM 50-300 M	280	DN 50	1 x 230 V ~	4 POLES	1430	0,21	0,25	0,33	1,1	8	450
DKLM 50-300 T	280	DN 50	3 x 230 - 400 V ~	4 POLES	1470	0,16	0,25	0,33	1-0.6	-	-
DKLM 50-600 M	280	DN 50	1 x 230 V ~	4 POLES	1340	0,3	0,25	0,33	1,4	8	450
DKLM 50-600 T	280	DN 50	3 x 230 - 400 V ~	4 POLES	1420	0,32	0,25	0,33	1.2-0.7	-	-
DKLP 50-900 M	280	DN 50	1 x 230 V ~	2 POLES	2900	0,7	0,75	1	3,3	20	450
DKLP 50-900 T	280	DN 50	3 x 230 - 400 V ~	2 POLES	2920	0,7	0,75	1	2.8/1.6	-	-
DKLP 50-1200 M	280	DN 50	1 x 230 V ~	2 POLES	2850	0,9	0,75	1	4,2	20	450
DKLP 50-1200 T	280	DN 50	3 x 230 - 400 V ~	2 POLES	2890	0,86	0,75	1	3.2/1.8	-	-

MODEL	A	B	B1	B2	C	DNA	DNM	D	D1	D2	D3	D4	H	H1	I	L	L1	L2	M	PACKING DIMENSIONS			VOLUME (m³)	WEIGHT kg	
																				L/A	L/B	H			
DKLM 50/300	110	434	217	217	120	50	50	90	110	125	165		410	73	240	280	140	140			540	420	610	0,138	51
DKLM 50/600	110	434	217	217	120	50	50	90	110	125	165	4 HOLES 18x25,5	410	73	240	280	140	140	4 HOLES 14		540	420	610	0,138	52
DKLP 50/900	110	434	217	217	120	50	50	90	110	125	165		410	73	240	280	140	140			540	420	610	0,138	54
DKLP 50/1200	110	434	217	217	120	50	50	90	110	125	165		410	73	240	280	140	140			540	420	610	0,138	54

DKLM / DKLP 65 - IN-LINE ELECTRIC PUMPS FOR HEATING, AIR CONDITIONING, REFRIGERATION, SOLAR, AND SANITARY SYSTEMS - SINGLE, FLANGED

Pumped liquid temperature range: from -15 °C to +120 °C - Maximum ambient temperature: +40 °C

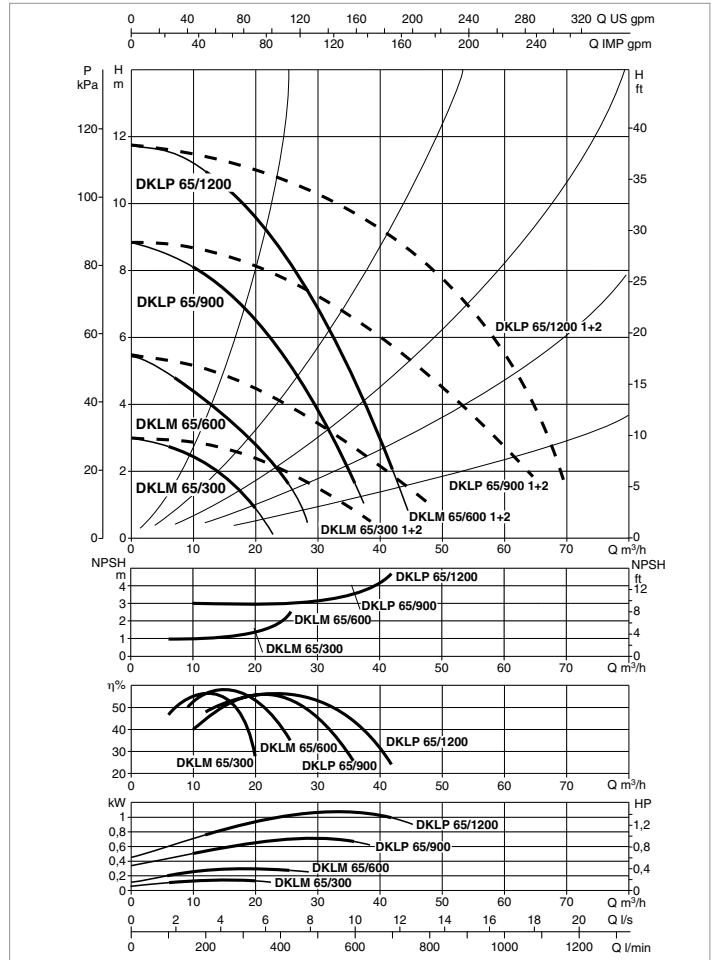
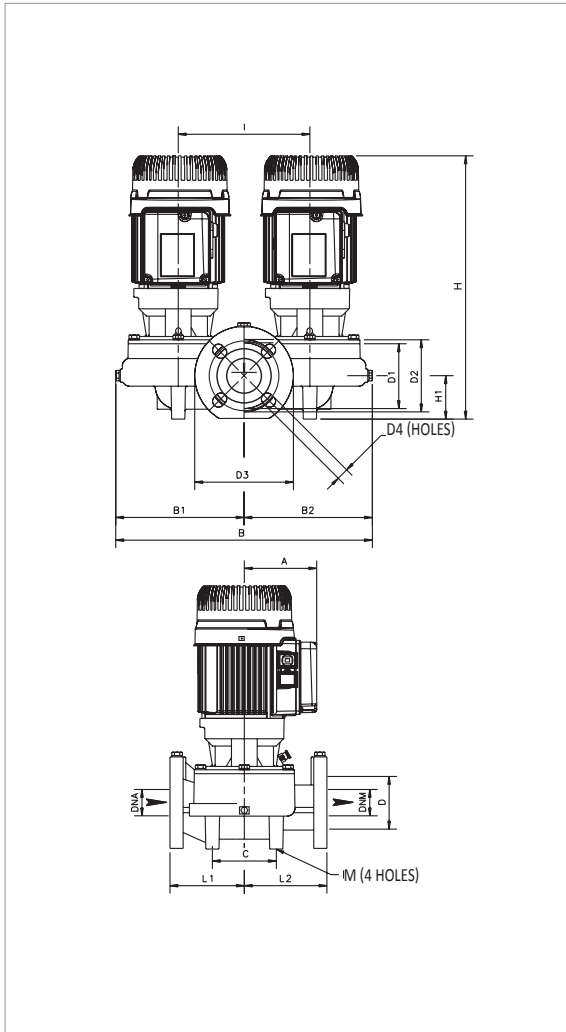

The performance curves are based on kinematic viscosity values = 1 mm²/s and density equal to 1000 kg/m³. Curve tolerance according to ISO 9906.

For the MEI index refer to the hydraulic data of the individual pump.

MODEL	CENTRE DISTANCE	PUMP CONNECTIONS	ELECTRICAL DATA						
			POWER INPUT 50 Hz	MOTOR TYPE	n r.p.m.	P1 MAX W	P2 NOMINAL		In A
							kW	HP	
DKLM 65-300 T	340	DN 65	3 x 230 - 400 V ~	4 POLES	1460	0,2	0,25	0,33	1/0.6
DKLM 65-600 T	340	DN 65	3 x 230 - 400 V ~	4 POLES	1400	0,36	0,37	0,5	1.2/0.7
DKLP 65-900 T	340	DN 65	3 x 230 - 400 V ~	2 POLES	2920	0,98	1,1	1,5	4/2.35
DKLP 65-1200 T	340	DN 65	3 x 230 - 400 V ~	2 POLES	2880	1,3	1,1	1,5	4.7/2.7

MODEL	A	B	B1	B2	C	DNA	DNM	D	D1	D2	D3	D4	H	H1	I	L	L1	L2	M	PACKING DIMENSIONS			VOLUME (m ³)	WEIGHT kg
																				L/A	L/B	H		
DKLM 65/300	110	455	226	229	140	65	65	110	130	145	185	4 HOLES 18x25,5	430	82	240	340	170	170	4 HOLES 14	540	420	610	0,138	55
DKLM 65/600	110	455	226	229	140	65	65	110	130	145	185		430	82	240	340	170	170		540	420	610	0,138	62
DKLP 65/900	110	455	226	229	140	65	65	110	130	145	185		430	82	240	340	170	170		540	420	610	0,138	66
DKLP 65/1200	110	455	226	229	140	65	65	110	130	145	185		430	82	240	340	170	170		540	420	610	0,138	66

DKLM / DKLP 80 - IN-LINE ELECTRIC PUMPS FOR HEATING, AIR CONDITIONING, REFRIGERATION, SOLAR, AND SANITARY SYSTEMS - SINGLE, FLANGED

Pumped liquid temperature range: from -15 °C to +120 °C - Maximum ambient temperature: +40 °C

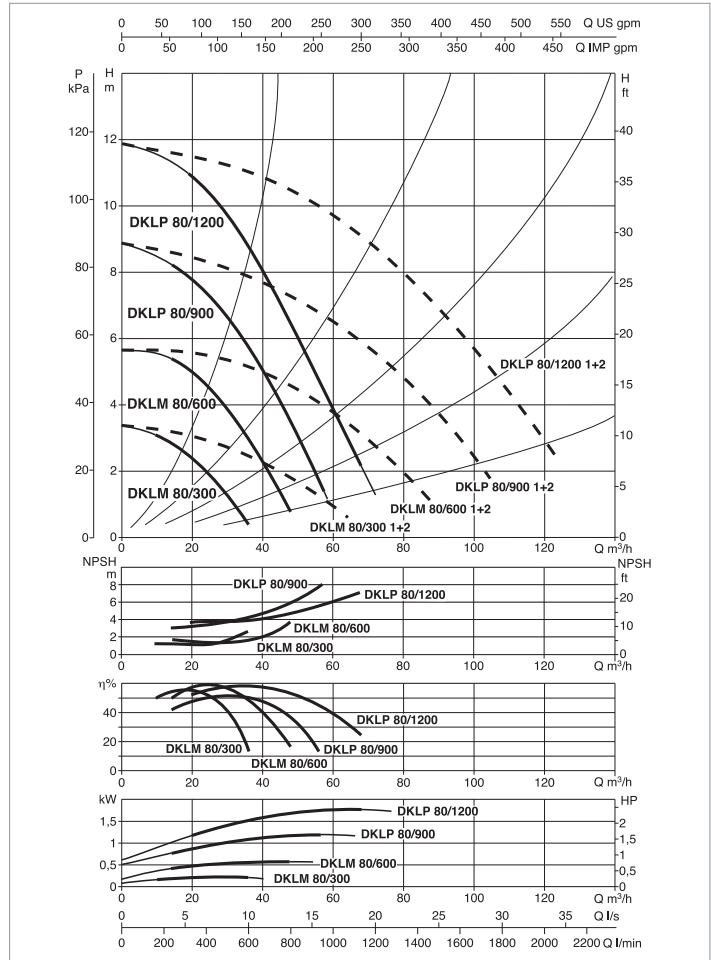
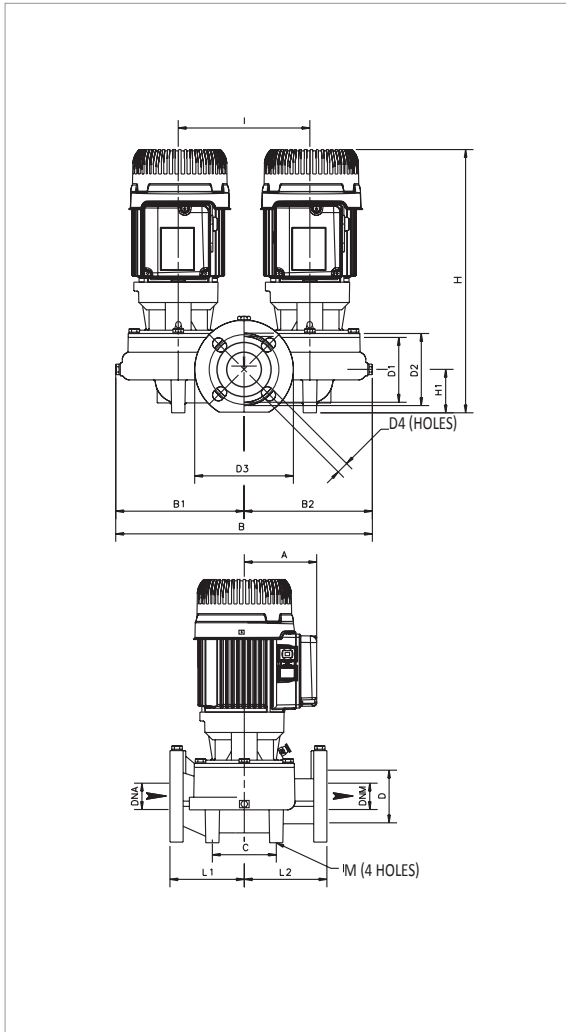

The performance curves are based on kinematic viscosity values = 1 mm²/s and density equal to 1000 kg/m³. Curve tolerance according to ISO 9906.
For the MEI index refer to the hydraulic data of the individual pump.

MODEL	CENTRE DISTANCE	PUMP CONNECTIONS	ELECTRICAL DATA						
			POWER INPUT 50 Hz	MOTOR TYPE	n r.p.m.	P1 MAX W	P2 NOMINAL		In A
							kW	HP	
DKLM 80-300 T	360	DN 80	3 x 230 - 400 V ~	4 POLES	1460	0,36	0,25	0,33	1.2/0.7
DKLM 80-600 T	360	DN 80	3 x 230 - 400 V ~	4 POLES	1400	0,75	0,75	1	2.8/1.6
DKLP 80-900 T	360	DN 80	3 x 230 - 400 V ~	2 POLES	2920	1,4	1,84	2,5	5.2/3
DKLP 80-1200 T	360	DN 80	3 x 230 - 400 V ~	2 POLES	2840	2,1	1,84	2,5	6.6/3.8

MODEL	A	B	B1	B2	C	DNA	DNM	D	D1	D2	D3	D4	H	H1	I	L	L1	L2	M	PACKING DIMENSIONS			VOLUME (m ³)	WEIGHT kg
																				L/A	L/B	H		
DKLM 80/300	110	463	230	233	150	80	80	128	150	150	200	4 HOLES 18x23	445	97	240	360	190	170	4 HOLES 14	540	420	610	0,138	62
DKLM 80/600	110	463	230	233	150	80	80	128	150	150	200		445	97	240	360	190	170		540	420	610	0,138	70
DKLP 80/900	110	463	230	233	150	80	80	128	150	150	200		445	97	240	360	190	170		540	420	610	0,138	76
DKLP 80/1200	110	463	230	233	150	80	80	128	150	150	200		445	97	240	360	190	170		540	420	610	0,138	76