

# EVOPlus<sup>+</sup> v3.0

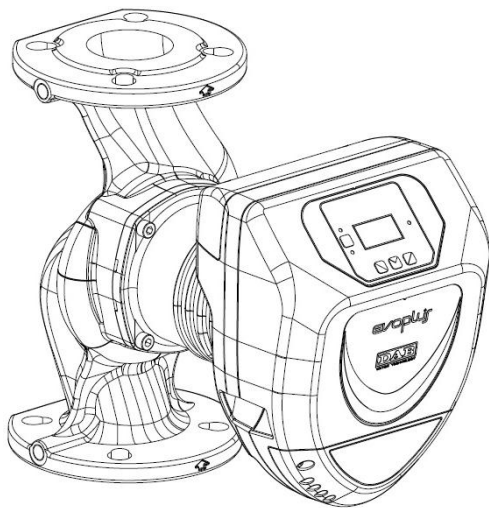

ISTRUZIONI PER L'INSTALLAZIONE E LA MANUTENZIONE  
INSTRUCTIONS FOR INSTALLATION AND MAINTENANCE  
INSTRUCCIONES PARA LA INSTALACIÓN Y EL MANTENIMIENTO  
INSTALLATIONS - OCH UNDERHÅLLSANVISNING  
INSTRUCTIONS POUR L'INSTALLATION ET LA MAINTENANCE  
INSTRUCTIES VOOR INGEBRUIKNAME EN ONDERHOUD  
INSTRUCTIUNI DE INSTALARE SI INTRETINERE  
INSTALLATIONSANWEISUNG UND WARTUNG  
INSTRUKCJA MONTAŻU I KONSERWACJI  
ΟΔΗΓΙΕΣ ΓΙΑ ΤΗΝ ΕΓΚΑΤΑΣΤΑΣΗ ΚΑΙ ΤΗ ΣΥΝΤΗΡΗΣΗ  
NÁVOD NA POUŽITÍ A ÚDRŽBU  
NÁVOD NA INŠTALÁCIU A ÚDRŽBU  
MONTAJ VE BAKIM İÇİN BİLGİLER  
UZSTĀDĪŠANAS UN TEHNISKĀS APKOPES ROKASGRĀMATA  
MONTAVIMO IR TECHNINĖS PRIEŽIŪROS INSTRUKCIJOS  
INSTRUÇÕES PARA A INSTALAÇÃO  
РУКОВОДСТВО ПО МОНТАЖУ И ТЕХНИЧЕСКОМУ ОБСЛУЖИВАНИЮ  
ASENNUS- JA HUOLTO-OHJEET  
NAVODILA ZA VGRADNJO IN UPORABO  
ИНСТРУКЦИЯ ЗА ИНСТАЛИРАНЕ И ОБСЛУЖВАНЕ  
HASZNÁLATI ÚTMUTATÓ A BEÁLLÍTÁSHOZ ÉS KARBANTARTÁSHOZ  
КЕРІВНИЦТВО З МОНТАЖУ ТА ТЕХНІЧНОГО ОБСЛУГОВУВАННЯ

B 120/220.32 M	B 120/220.32 SAN M	D 120/220.32 M
B 40/220.40 M B 60/220.40 M B 80/220.40 M B 100/220.40 M B 120/250.40 M B 150/250.40 M B 180/250.40 M	B 120/250.40 SAN M B 150/250.40 SAN M B 180/250.40 SAN M	D 40/220.40 M D 60/220.40 M D 80/220.40 M D 100/220.40 M D 120/250.40 M D 150/250.40 M D 180/250.40 M
B 40/240.50 M B 60/240.50 M B 80/240.50 M B 100/280.50 M B 120/280.50 M B 150/280.50 M B 180/280.50 M	B 100/280.50 SAN M B 120/280.50 SAN M B 150/280.50 SAN M B 180/280.50 SAN M	D 40/240.50 M D 60/240.50 M D 80/240.50 M D 100/280.50 M D 120/280.50 M D 150/280.50 M D 180/280.50 M
B 40/340.65 M B 60/340.65 M B 80/340.65 M B 100/340.65 M B 120/340.65 M B 150/340.65 M	B 40/340.65 SAN M B 60/340.65 SAN M B 80/340.65 SAN M B 100/340.65 SAN M B 120/340.65 SAN M B 150/340.65 SAN M	D 40/340.65 M D 60/340.65 M D 80/340.65 M D 100/340.65 M D 120/340.65 M D 150/340.65 M
B 40/360.80 M B 60/360.80 M B 80/360.80 M B 100/360.80 M B 120/360.80 M		D 40/360.80 M D 60/360.80 M D 80/360.80 M D 100/360.80 M D 120/360.80 M
B 40/450.100 M B 60/450.100 M B 80/450.100 M B 100/450.100 M B 120/450.100 M		D 40/450.100 M D 60/450.100 M D 80/450.100 M D 100/450.100 M D 120/450.100 M

ITALIANO	pag.	01
ENGLISH	page	12
ESPAÑOL	pág	23
SVENSKA	sid	34
FRANÇAIS	page	45
NEDERLANDS	bladz	56
ROMANA	pag.	67
DEUTSCH	Seite	78
POLSKI	strona	89
ΕΛΛΗΝΙΚΑ	Σελίδα	100
ČESKY	strana	111
SLOVENSKÝ JAZYK	str.	121
TÜRÇE	say	132
LATVIEŠU	lpp.	143
LIETUVIŠKAI	psl.	154
PORTUGUÊS	pág	165
РУССКИЙ	стр.	176
SUOMI	sivu	187
SLOVENŠČINA	str.	198
БЪЛГАРСКИ	Стр.	209
MAGYAR	Old.	220
УКРАЇНСЬКА	стр.	231

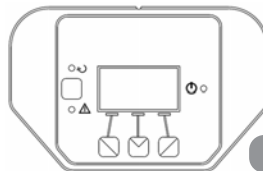
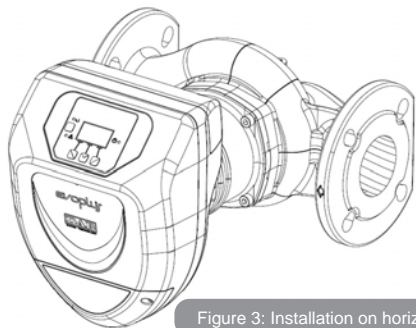
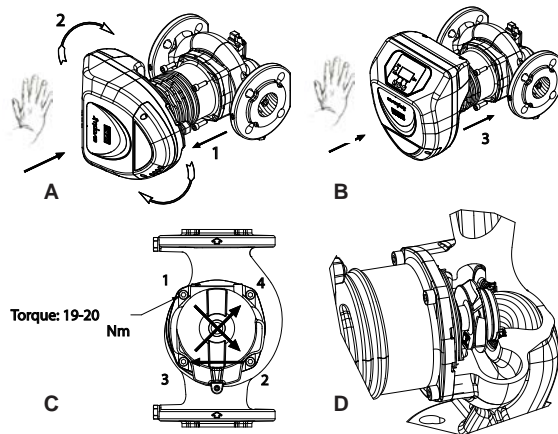
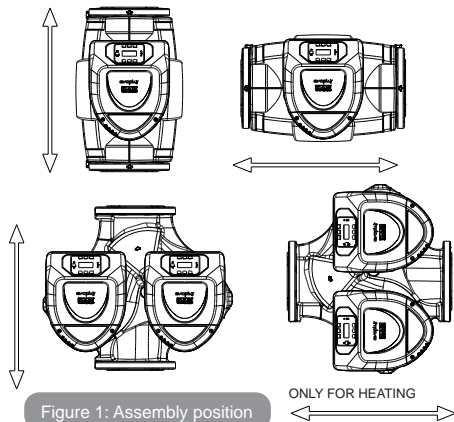

EVOPLUS	Hmax [m]	Qmax [m3/h]	EVOPLUS	Hmax [m]	Qmax [m3/h]
B 120/220.32 M - B 120/220.32 SAN M*	12.0	17.01	D 120/220.32 M	12.0	30.62
B 40/220.40 M	4.0	12.18	D 40/220.40 M	4.0	21.91
B 60/220.40 M	6.0	15.69	D 60/220.40 M	6.0	28.24
B 80/220.40 M	8.0	18.58	D 80/220.40 M	8.0	33.44
B 100/220.40 M	10.0	20.64	D 100/220.40 M	10.0	37.15
B 120/250.40 M - B 120/250.40 SAN M*	12.0	23.48	D 120/250.40 M	12.0	42.26
B 150/250.40 M - B 150/250.40 SAN M*	15.0	25.65	D 150/250.40 M	15.0	46.17
B 180/250.40 M - B 180/250.40 SAN M*	18.0	25.65	D 180/250.40 M	18.0	46.17
B 40/240.50 M	4.0	20.27	D 40/240.50 M	4.0	36.49
B 60/240.50 M	6.0	25.20	D 60/240.50 M	6.0	45.36
B 80/240.50 M	8.0	27.51	D 80/240.50 M	8.0	49.52
B 100/280.50 M - B 100/280.50 SAN M*	10.0	30.08	D 100/280.50 M	10.0	54.14
B 120/280.50 M - B 120/280.50 SAN M*	12.0	32.98	D 120/280.50 M	12.0	59.36
B 150/280.50 M - B 150/280.50 SAN M*	15.0	35.02	D 150/280.50 M	15.0	63.04
B 180/280.50 M - B 180/280.50 SAN M*	18.0	37.02	D 180/280.50 M	18.0	66.64
B 40/340.65 M - B 40/340.65 SAN M*	4.0	27.90	D 40/340.65 M	4.0	50.22
B 60/340.65 M - B 60/340.65 SAN M*	6.0	34.47	D 60/340.65 M	6.0	62.05
B 80/340.65 M - B 80/340.65 SAN M*	8.0	38.30	D 80/340.65 M	8.0	68.94
B 100/340.65 M - B 100/340.65 SAN M*	10.0	41.71	D 100/340.65 M	10.0	75.08
B 120/340.65 M - B 120/340.65 SAN M*	12.0	44.63	D 120/340.65 M	12.0	80.33
B 150/340.65 M - B 150/340.65 SAN M*	15.0	53.44	D 150/340.65 M	15.0	96.19
B 40/360.80 M	4.0	37.30	D 40/360.80 M	4.0	67.14
B 60/360.80 M	6.0	43.54	D 60/360.80 M	6.0	78.37
B 80/360.80 M	8.0	42.84	D 80/360.80 M	8.0	77.11
B 100/360.80 M	10.0	49.02	D 100/360.80 M	10.0	88.24
B 120/360.80 M	12.0	58.12	D 120/360.80 M	12.0	104.62
B 40/450.100 M	4.0	45.29	D 40/450.100 M	4.0	81.52
B 60/450.100 M	6.0	50.77	D 60/450.100 M	6.0	91.39
B 80/450.100 M	8.0	56.85	D 80/450.100 M	8.0	102.33
B 100/450.100 M	10.0	61.60	D 100/450.100 M	10.0	110.88
B 120/450.100 M	12.0	63.73	D 120/450.100 M	12.0	114.71

\*This circulator is suitable for drinking water only.

Table: Maximum head (Hmax) and maximum flow rate (Qmax) of EVOPLUS circulators

Table: Energy Efficiency Index - EEI			
EVOPLUS B 120/220.32 M	0,22	EVOPLUS D 120/220.32 M	0,22
EVOPLUS B 40/220.40 M	0,23	EVOPLUS D 40/220.40 M	0,23
EVOPLUS B 60/220.40 M	0,23	EVOPLUS D 60/220.40 M	0,23
EVOPLUS B 80/220.40 M	0,21	EVOPLUS D 80/220.40 M	0,23
EVOPLUS B 100/220.40 M	0,20	EVOPLUS D 100/220.40 M	0,23
EVOPLUS B 120/250.40 M	0,20	EVOPLUS D 120/250.40 M	0,23
EVOPLUS B 150/250.40 M	0,20	EVOPLUS D 150/250.40 M	0,23
EVOPLUS B 180/250.40 M	0,20	EVOPLUS D 180/250.40 M	0,23
EVOPLUS B 40/240.50 M	0,23	EVOPLUS D 40/240.50 M	0,23
EVOPLUS B 60/240.50 M	0,21	EVOPLUS D 60/240.50 M	0,22
EVOPLUS B 80/240.50 M	0,21	EVOPLUS D 80/240.50 M	0,22
EVOPLUS B 100/280.50 M	0,20	EVOPLUS D 100/280.50 M	0,22
EVOPLUS B 120/280.50 M	0,19	EVOPLUS D 120/280.50 M	0,22
EVOPLUS B 150/280.50 M	0,19	EVOPLUS D 150/280.50 M	0,21
EVOPLUS B 180/280.50 M	0,19	EVOPLUS D 180/280.50 M	0,21
EVOPLUS B 40/340.65 M	0,21	EVOPLUS D 40/340.65 M	0,21
EVOPLUS B 60/340.65 M	0,20	EVOPLUS D 60/340.65 M	0,21
EVOPLUS B 80/340.65 M	0,19	EVOPLUS D 80/340.65 M	0,21
EVOPLUS B 100/340.65 M	0,18	EVOPLUS D 100/340.65 M	0,20
EVOPLUS B 120/340.65 M	0,18	EVOPLUS D 120/340.65 M	0,20
EVOPLUS B 150/340.65 M	0,18	EVOPLUS D 150/340.65 M	0,20
EVOPLUS B 40/360.80 M	0,19	EVOPLUS D 40/360.80 M	0,20
EVOPLUS B 60/360.80 M	0,20	EVOPLUS D 60/360.80 M	0,20
EVOPLUS B 80/360.80 M	0,20	EVOPLUS D 80/360.80 M	0,20
EVOPLUS B 100/360.80 M	0,19	EVOPLUS D 100/360.80 M	0,19
EVOPLUS B 120/360.80 M	0,19	EVOPLUS D 120/360.80 M	0,19
EVOPLUS B 40/450.100 M	0,19	EVOPLUS D 40/450.100 M	0,19
EVOPLUS B 60/450.100 M	0,18	EVOPLUS D 60/450.100 M	0,19
EVOPLUS B 80/450.100 M	0,18	EVOPLUS D 80/450.100 M	0,20
EVOPLUS B 100/450.100 M	0,19	EVOPLUS D 100/450.100 M	0,20
EVOPLUS B 120/450.100 M	0,19	EVOPLUS D 120/450.100 M	0,20

The benchmark for the most efficient circulators is  $EEI \leq 0,20$

## INDEX

<b>1. Particular warnings</b> .....	13
<b>2. Pumped liquids</b> .....	13
<b>3. Electromagnetic Compatibility (EMC)</b> .....	13
<b>4. Management</b> .....	13
4.1 Storage .....	13
4.2 Transport .....	13
4.3 Weight .....	13
<b>5. Installation</b> .....	13
5.1 Circular Installation and Maintenance .....	13
5.2 Rotation of the Motor Heads .....	14
5.3 Non-return valve .....	14
<b>6. Electrical connections</b> .....	14
6.1 Power supply connection .....	15
6.2 Electrical connections of Inputs, Outputs and MODBUS .....	15
6.2.1 Digital Inputs .....	15
6.2.2 MODBUS and LON Bus .....	15
6.2.3 Analogue Input and PWM .....	16
6.2.4 Outputs .....	16
6.3 Connections for Twin Systems .....	16
<b>7. Start</b> .....	16
<b>8. Functions</b> .....	17
8.1 Regulating Modes .....	17
8.1.1 Regulation with Proportional Differential Pressure .....	17
8.1.2 Regulation with Constant Differential Pressure .....	17
8.1.3 Regulation with constant curve .....	17
8.1.4 Regulation with Constant and Proportional Differential Pressure depending on the Water Temperature .....	17
<b>9. Control Panel</b> .....	18
9.1 Graphic Display .....	18
9.2 Navigation Buttons .....	18
9.3 Warning Lights .....	18
<b>10. Menus</b> .....	18
<b>11. Factory settings</b> .....	20
<b>12. TypeS of Alarm</b> .....	21
<b>13. Error Condition And Reset</b> .....	21

## INDEX OF FIGURES

Figure 1: Assembly position .....	1A
Figure 2: Instructions for motor head assembly .....	1A
Figure 3: Installation on horizontal pipes .....	1A
Figure 4: Electrical connections (front) .....	14
Figure 5: Electrical connections (rear) .....	14
Figure 6: Pull-out terminal board for supply .....	15
Figure 7: Pull-out 13-pole terminal board: digital inputs and MODBUS .....	15
Figure 8: Pull-out 13-pole terminal board: 0-10V inputs and PWM .....	16
Figure 9: Pull-out 6-pole terminal board: example of output connection .....	16
Figure 10: Control panel .....	1A

## INDEX OF TABLES

Table 1: Electrical connections .....	14
Table 2: Digital inputs IN1 and IN2 .....	15
Table 3: RS_485 MODBUS terminals .....	15
Table 4: Outputs OUT1 and OUT2 .....	16
Table 5: Characteristics of the output contacts .....	16
Table 6: Factory settings .....	20
Table 7: List of alarms .....	21

<b>Table: Maximum head (Hmax) and maximum flow rate (Qmax) of EVOPLUS circulators</b> .....	2A
---	----

<b>Table: Energy Efficiency Index - EEI</b> .....	3A
---	----

## 1. PARTICULAR WARNINGS



Ensure that the product has not suffered any damage during transport or storage. Check that the outer casing is unbroken and in excellent conditions.



**Always switch off the mains power supply before working on the electrical or mechanical part of the system. Wait for the warning lights on the control panel to go out before opening the appliance. The capacitor of the direct current intermediate circuit remains charged with dangerously high voltage even after the mains power has been turned off.**

**Only firmly cabled mains connections are admissible. The appliance must be earthed (IEC 536 class 1, NEC and other applicable standards).**



**Mains terminals and motor terminals may still have dangerous voltage when the motor is stopped.**



**If the power cable is damaged, it must be replaced by the technical assistance service or by qualified personnel, so as to avoid any risk.**

## 2. PUMPED LIQUIDS

The machine has been designed and made for pumping water, free from explosive substances and solid particles or fibres, with a density of 1000 Kg/m<sup>3</sup>, a kinematic viscosity of 1mm<sup>2</sup>/s and non chemically aggressive liquids. It is possible to use ethylene glycol in a percentage of no more than 30%.

## 3. ELECTROMAGNETIC COMPATIBILITY (EMC)

EVOPLUS circulators respect standard EN 61800-3, in the C2 category, for electromagnetic compatibility.

- Electromagnetic emissions - Industrial environment (in some cases restrictive measures may be requested).
- Conducted emissions - Industrial environment (in some cases restrictive measures may be requested).

## 4. MANAGEMENT

### 4.1 Storage

All the circulators must be stored in a dry covered place, with possibly constant air humidity, free from vibrations and dust. They are supplied in their original pack in which they must remain until the time of installation. If this is not the case, accurately close the suction and delivery mouth.

### 4.2 Transport

Avoid subjecting the products to needless impacts and collisions. To lift and transport the circulator use lifting devices with the aid of the pallet supplied with it (if contemplated).

### 4.3 Weight

The adhesive plate on the packaging indicates the total weight of the circulator.

## 5. INSTALLATION

Carefully follow the advice in this chapter to carry out correct electrical, hydraulic and mechanical installation.



**Ensure that the voltage and frequency on the data plate of the EVOPLUS circulator are the same as those of the power mains.**

### 5.1 Circular Installation and Maintenance



**Always install the EVOPLUS circulator with the motor shaft in a horizontal position. Install the electronic control device in a vertical position (see Figure 1)**

- The circulator may be installed in heating and conditioning systems on either the delivery pipe or the return pipe; the arrow marked on the pump body indicates the direction of flow.
- Install the circulator as far as possible above the minimum boiler level and as far as possible from bends, elbows and junction boxes.
- To facilitate control and maintenance operations, install an interception valve both on the suction pipe and on the delivery pipe.
- **Before installing the circulator, accurately flush the system with only water at 80°C.** Then drain the system completely to eliminate any harmful substance that may have got into circulation.
- Assemble in such a way as to avoid dripping on the motor and on the electronic control device during both installation and maintenance.
- Avoid mixing additives derived from hydrocarbons and aromatic products with the circulating water. It is recommended that the addition of antifreeze, where necessary, should not exceed 30%.
- In the event of heat insulation use the special kit (if provided) and ensure that the condensate draining holes in the motor casing are not closed or partly blocked.
- To guarantee maximum efficiency of the system and long life of the circulator it is recommended to use magnetic sludge-removing filters to separate and collect any impurities present in the system (particles of sand, particles of iron and sludge)



Never insulate the electronic control device.

- In the case of maintenance, always use a set of new gaskets.

### 5.2 Rotation of the Motor Heads

If the circulator is installed on pipes in a horizontal position, it will be necessary to rotate the motor with the respective electronic device through 90 degrees in order to maintain the grade of IP protection and to allow the user a more convenient interaction with the graphic interface (see Figure 2-3).



Before rotating the circulator, ensure that it has been completely drained.

Should it be necessary to rotate the motor heads, follow the instructions below with care to ensure correct installation:

1. Unscrew the 4 screws fixing the motor assembly to the pump body (figure A).
2. Rotate the motor assembly keeping it in the seat where it couples with the pump body (figure A-B).
3. Once the head has been rotated into the desired position, tighten the 4 screws, always proceeding in cross formation (figure C).

If the motor assembly has been removed from its seat, pay the greatest attention during assembly, taking care to insert the impeller completely in the floating ring before tightening the retaining screws (figure D). If it has been correctly assembled, the motor assembly rests completely on the pump body.



Incorrect assembly may damage the impeller, causing a typical rubbing noise when the circulator starts.



The electronic control device must always remain in vertical position!



Ensure that the connecting cable of the pressure sensor never comes in contact with the motor casing.

### 5.3 Non-return valve

If the system is equipped with a non-return valve, ensure that the minimum pressure of the circulator is always higher than the valve closing pressure.

## 6. ELECTRICAL CONNECTIONS

The electrical connections must be made by expert, qualified personnel.

- The circulator does not require any external motor protection.
- Ensure that the supply voltage and frequency are the same as the values indicated on the electrical data plate of the circulator.

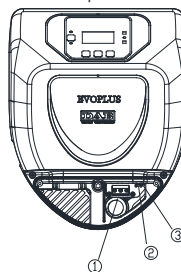

Figure 4: Electrical connections (front)

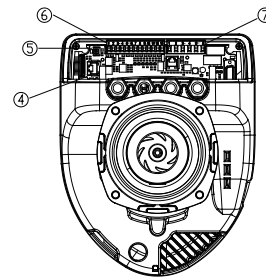

Figure 5: Electrical connections (rear)

Reference (Figure 4 and Figure 5)	Description
1	Pull-out terminal board for connection of the supply line: 1x220-240 V, 50/60 Hz
2	auxiliary LED
3	system live indicating LED
4	Connector for connecting twin circulators
5	Connector for connecting the fluid pressure and temperature sensor (standard)
6	Pull-out 13-pole terminal board for connecting the inputs and the MODBUS systems
7	Pull-out 6-pole terminal board for alarm signals and system status

Table 1 Electrical connections



## 6.1 Power supply connection

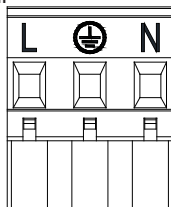

Figure 6: Pull-out terminal board for supply

**Before supplying power to the circulator, ensure that the cover of the EVOPLUS control panel is perfectly closed.**

## 6.2 Electrical connections of Inputs, Outputs and MODBUS

EVOPLUS circulators are equipped with digital and analogue inputs and digital outputs so as to be able to realise interface solutions with more complex installations. For the installer it will be sufficient to wire up the desired input and output contacts and to configure their functions as desired (see par. 8.2.1 par. 6.2.2 par. 6.2.3 and par. 6.2.4).

### 6.2.1 Digital Inputs

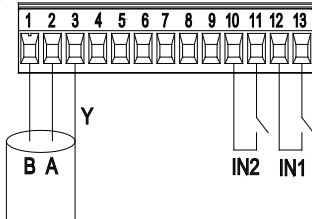

Figure 7: Pull-out 13-pole terminal board: digital inputs and MODBUS

With reference to Figure 7 the digital inputs available are:

Input	Terminal no.	Type of contact	Associated function
IN1	12	Clean contact	<b>EXT:</b> If is activated from the control panel (see par. 12 Page 11.0 of the EVOPLUS menu) it will be possible to command the switching on and off of the pump in remote mode.
	13		
IN2	10	Clean contact	<b>Economy:</b> If is activated from the control panel (see par. 12 Page 5.0 of the EVOPLUS menu) it will be possible to active the set-point reduction function in remote mode.
	11		

Table 2: Digital inputs IN1 and IN2

If the EXT and Economy functions have been activated from the control panel, the system will behave as follows:

IN1	IN2	System Status
Open	Open	Pump stopped
Open	Closed	Pump stopped
Closed	Open	Pump running with set-point set by the user
Closed	Closed	Pump running with reduced set-point

### 6.2.2 MODBUS and LON Bus

EVOPLUS circulators provide serial communication through an input RS-485. The communication is realised according to MODBUS specifications.

With MODBUS it is possible to set the circulator operating parameters in remote mode such as, for example, the desired differential pressure, the influence of temperature, the regulating mode, etc. At the same time the circulator can provide important information on the system status.

For the electrical connections refer to Figure 6 and to Table 3:

MODBUS Terminals	Terminal no.	Description
A	2	Terminal not inverted (+)
B	1	Terminal inverted (-)
Y	3	GND

Table 3: RS\_485 MODBUS terminals

The MODBUS communication configuration parameters are available in the advanced menu see Par.10). EVOPLUS circulators also have the possibility of communicating on LON bus through external interface devices.

Further information and details on the MODBUS and LON bus interface are available at the following link: <http://www.dabpumps.com/evoplus>

### 6.2.3 Analogue Input and PWM

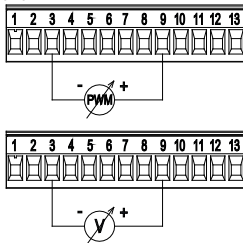

Figure 8: Pull-out 13-pole terminal board: 0-10V inputs and PWM

Figure 8 shows the wiring diagram of the external signals 0-10V and PWM. As may be seen from the figure the 2 signals share the same terminals on the terminal board, so they are mutually exclusive. If you want to use an analogue control signal, you will have to set the type of signal from the menu (see par. 10).

Further information and details on the MODBUS and LON bus interface are available for download at the following link: <http://www.dabpumps.com/evoplus>

### 6.2.4 Outputs

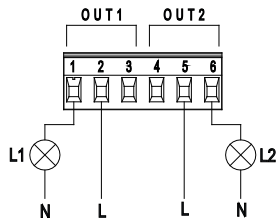

Figure 9: Pull-out 6-pole terminal board: example of output connection

With reference to Figure 9 the digital outputs available are:

Output	Terminal no.	Type of contact	Associated function
OUT1	1	NC	Presence/Absence of alarms in the system
	2	COM	
	3	NO	
OUT2	4	NC	Pump running/Pump stopped
	5	COM	
	6	NO	

Table 4: Outputs OUT1 and OUT2

The outputs OUT1 and OUT2 are available on the pull-out 6-pole terminal board as specified in Table 4 which also shows the type of contact (NC = Normally Closed, COM = Common, NO = Normally Open). The electrical characteristics of the contacts are shown in Table 5. In the example shown in Figure 8 the light L1 is lit when there is an alarm in the system and it goes off when no kind of malfunction is found, whereas the light L2 is lit when the pump is running and goes off when the pump is stopped.

Characteristics of the output contacts	
Max. bearable voltage [V]	250
Max. bearable current [A]	5 If resistive load
	2,5 If inductive load
Max. accepted cable section [mm <sup>2</sup> ]	2,5

Table 5: Characteristics of the output contacts

### 6.3 Connections for Twin Systems

**!** For correct operation of the twin system, all the external connections of the pull-out 13-pole terminal board must be connected in parallel between the 2 EVOPLUS respecting the numbering of the individual terminals.

#### 7. START

**!** All the starting operations must be performed with the cover of the EVOPLUS control panel closed. Start the system only when all the electrical and hydraulic connections have been completed.

Avoid running the circulator when there is no water in the system.



**As well as being at a high temperature and pressure, the fluid in the system may also be in the form of steam. DANGER OF SCALDING!**  
It is dangerous to touch the circulator. DANGER OF SCALDING!

Once all the electrical and hydraulic connections have been made, fill the system with water and if necessary with glycol (for the maximum glycol percentage see par. 2) and feed the system. Once the system has been started it is possible to modify the operating modes to adapt better to the plant requirements (see par.10).

## 8. FUNCTIONS

### 8.1 Regulating Modes

EVOPLUS circulators allow the following regulating modes depending on plant requirements:

- Proportional differential pressure regulation depending on the flow present in the plant.
- Proportional differential pressure regulation with set-point depending on the external signal 0-10V or PWM.
- Proportional differential pressure regulation depending on the flow present in the plant and on the liquid temperature.
- Constant differential pressure regulation.
- Constant differential pressure regulation with set-point depending on the external signal 0-10V or PWM.
- Constant differential pressure regulation with variable set-point depending on the liquid temperature.
- Regulation with constant curve.
- Regulation with constant curve with rotation speed depending on the external signal 0-10V or PWM.

The regulating mode may be set through the EVOPLUS control panel (see par. 10).

#### 8.1.1 Regulation with Proportional Differential Pressure

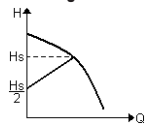

In this regulating mode the differential pressure is reduced or increased as the demand for water decreases or increases.

The  $H_s$  set point may be set from the display or by an external signal 0-10V or PWM.

Regulation indicated for:

- Heating and conditioning plants with high load losses
- Two-pipe systems with thermostatic valves and head  $\geq 4$  m
- Plants with secondary differential pressure regulator

- Primary circuits with high load losses
- Domestic water recirculating systems with thermostatic valves on the rising columns

#### 8.1.2 Regulation with Constant Differential Pressure

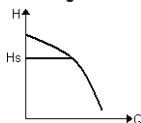

In this regulating mode the differential pressure is kept constant, irrespective of the demand for water,

The  $H_s$  set point may be set from the display or by an external signal 0-10V or PWM.

Regulation indicated for:

- Heating and conditioning plants with low load losses
- Two-pipe systems with thermostatic valves and head  $\leq 2$  m
- Single-pipe systems with thermostatic valves
- Plants with natural circulation
- Primary circuits with low load losses
- Domestic water recirculating systems with thermostatic valves on the rising columns.

#### 8.1.3 Regulation with constant curve

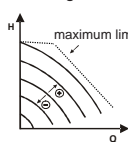

In this regulating mode the circulator works on characteristic curves at a constant speed. The operating curve is selected by setting the rotation speed through a percentage factor. The value 100% indicates the maximum limit curve. The actual rotation speed may depend on the power and differential pressure limits of your circulator model.

The rotation speed may be set from the display or by an external signal 0-10V or PWM.

Regulation indicated for heating and conditioning plants with constant flow.

#### 8.1.4 Regulation with Constant and Proportional Differential Pressure depending on the Water Temperature

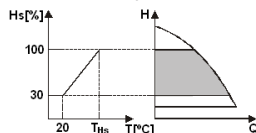

In this regulating mode the regulating set point  $H_s$  is reduced or increased according to the water temperature.  $T_{Hs}$  may be set from 0°C to 100 °C in order to allow operation in both heating and conditioning plants.

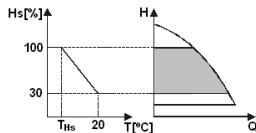

Regulation indicated for:

- Plants with variable flow (two-pipe heating plants), where a further reduction of the circulator performance is ensured depending on the lowering of the temperature of the circulating liquid, when the demand for heating is lower.
- Plants with constant flow (single-pipe and under-floor heating plants), where the circulator performance can be regulated only by activating the temperature influence function.

## 9. CONTROL PANEL

The functions of EVOPLUS circulators offer 2 menus: **user menu** and **advanced menu**. The user menu is accessible from the Home Page by pressing and releasing the central "Menu" button.

The user menu is accessible from the Home Page by holding down the central "Menu" button for 5 seconds

### 9.1 Graphic Display

Using the graphic display it will be possible to navigate in an easy and intuitive menu which will enable you to check and modify the system operating mode, the enabling of the inputs and the working set-point. It will also be possible to view the system status and the log of any alarms memorised by the system.

### 9.2 Navigation Buttons

4 buttons are provided for navigating in the menu: 3 buttons under the display and 1 at the side. The buttons under the display are called active buttons and the one at the side is called hidden button. Each page of the menu is made in such a way as to indicate the function associated with the 3 active buttons (the ones under the display).

### 9.3 Warning Lights

**Yellow light:** System live signal.

If lit, it means that the system is live.



**Never remove the cover if the yellow light is lit.**

**Red light:** Warning of an alarm/malfunction present in the system.

If the light is blinking it is a non-blocking alarm and the pump can still be controlled. If the light is fixed it is a blocking alarm and the pump cannot be controlled.

**Green light:** Pump ON/OFF signal.

If lit, the pump is running. If off, the pump is stopped.

## 10 MENU

EVOPLUS circulators offer 2 menus: **user menu** and **advanced menu**.

The user menu is accessible from the Home Page by pressing and releasing the central "Menu" button.

The user menu is accessible from the Home Page by holding down the central "Menu" button for 5 seconds

Below are shown the user menu pages with which it is possible to check the system status and modify its settings.

Instead on the advanced menu there are the configuration parameters for communication with MODBUS systems (for further details visit the link: <http://www.dabpump.com/evoplus/>). To leave the advanced menu you must scroll through all the parameters using the central button.

If the menu pages show a key at bottom left it means that it is not possible to change the settings. To unblock the menus go to the Home Page and press the hidden button and the button under the key at the same time until the key disappears.

**If no button is pressed for 60 minutes, the settings are automatically blocked and the display switches off. When any button is pressed the display lights up again and the "Home Page" appears.**









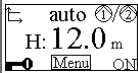
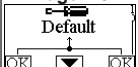

To navigate in the menus, press the central button.





To return to the previous page, hold down the hidden button, then press and release the central button.

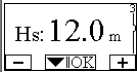

To modify the settings use the left and right buttons.

To confirm the change of a setting, hold down the central button "OK" for 3 seconds.

Confirmation will be indicated by the following icon:

<p><b>Home Page</b></p> 	<p>The main settings of the system are graphically summed up on the Home Page.</p> <p>The icon at top left indicates the type of regulation selected.</p> <p>The icon at centre top indicates the operating mode selected (auto or economy).</p> <p>The icon at top right indicates the presence of a single or twin inverter. The rotation of the icon ① or ② indicates which circulation pump is operating.</p> <p>At the centre of the Home Page is a read-only parameter which can be chosen from a small set of parameters on Page 9.0 of the menu.</p> <p>From the Home Page it is possible to access the page for regulating the contrast of the display: hold down the hidden button, then press and release the right button.</p> <p>EVOPLUS circulators offer 2 menus: user menu and advanced menu. The user menu is accessible from the Home Page by pressing and releasing the central "Menu" button.</p> <p>The user menu is accessible from the Home Page by holding down the central "Menu" button for 5 seconds.</p>
<p><b>Page 1.0</b></p> 	<p>The factory settings are set from Page 1.0 by holding down the left and right buttons at the same time for 3 seconds.</p> <p>The resetting of the factory settings will be notified by the appearance of the symbol  next to the word "Default".</p>
<p><b>Page 2.0</b></p> 	<p>The regulating mode is set from Page 2.0. You can choose between the following modes:</p> <ol style="list-style-type: none"> <li> Proportional differential pressure regulation.</li> <li> EXT = Proportional differential pressure regulation with set-point set by external signal (0-10V or PWM).</li> <li> Proportional differential pressure regulation with set-point depending on temperature.</li> <li> Regulation with constant differential pressure.</li> <li> EXT = Constant differential pressure regulation with set-point set by external signal (0-10V or PWM).</li> <li> = Constant differential pressure regulation with set-point depending on temperature.</li> <li> = Regulation with constant curve with rotation speed set from the display.</li> <li> EXT = Regulation with constant curve with rotation speed set by an external signal (0-10V or PWM).</li> </ol>

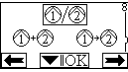
<p><b>Page 2.0</b> displays 3 icons which represent:</p> <ul style="list-style-type: none"> <li>- central icon = setting currently selected</li> <li>- right icon = next setting</li> <li>- left icon = previous setting</li> </ul>	
<p><b>Page 3.0</b></p> 	<p>The regulating set-point can be modified from Page 3.0. Depending on the type of regulation chosen on the previous page, the set-point to be set will be a head or, in the case of a Constant Curve, a percentage of the rotation speed.</p>
<p><b>Page 4.0</b></p> 	<p>On Page 4.0 it is possible to modify the parameter THs with which to make the curve depending on temperature (see Par. 8.1.4).</p> <p>This page will be displayed only for the regulating modes depending on fluid temperature.</p>
<p><b>Page 5.0</b></p> 	<p>Page 5.0 allows you to set the "auto" or "economy" operating mode.</p> <p>"Auto" mode disables the reading of the status of digital input IN2 and in fact the system always activates the set-point set by the user.</p> <p>"Economy" mode enables the reading of the status of digital input IN2. When input IN2 is energised the system activates a percentage reduction of the set-point set by the user (Page 6.0 of the EVOPLUS menu).</p> <p>For the connection of the inputs see par. 6.2.1</p>
<p><b>Page 6.0</b></p> 	<p>Page 6.0 is displayed if "economy" mode has been chosen on page 5.0 and allows setting of the percentage value of the set-point.</p> <p>This reduction will be carried out if digital input IN2 is energised.</p>
<p><b>Page 7.0</b></p> 	<p>Page 7.0 is displayed if an operating mode has been chosen with set-point regulated by an external signal.</p> <p>This page allows you to choose the type of control signal: analogue 0-10V (positive or negative increase) or PWM (positive or negative increase).</p>

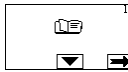
<p><b>Page 8.0</b></p> 	<p>If a twin system is used (see Par. 6.3) on page 8.0 you can set one of the 3 possible twin operation modes:</p> <p>②+① <b>Alternate every 24h:</b> The 2 circulators alternate in regulation every 24 operating hours. If one of the 2 malfunctions, the other takes over regulation.</p> <p>②+① <b>Simultaneous:</b> The 2 circulators work at the same time and at the same speed. This mode is useful when a flow rate is required that cannot be provided by a single pump.</p> <p>②+① <b>Main/Reserve:</b> Regulation is always performed by the same circulator (Main), the other (Reserve) takes over only if there is a malfunction of the Main one.</p> <p>If the twin communication cable is disconnected the systems automatically figure as Single, working completely independent of each other.</p>
<p><b>Page 9.0</b></p> 	<p>On page 9.0 it is possible to choose the parameter to be displayed on the Home Page:</p> <p>H: Measured head expressed in metres Q: Estimated flow rate expressed in m3/h S: Rotation speed expressed in revs per minute (rpm) E: Head requested by external signal 0-10V or PWM, if active P: Power distributed expressed in kW h: Operating hours T: Liquid temperature measured with the sensor fitted on board T1: Liquid temperature measured with an external sensor</p>
<p><b>Page 10.0</b></p> 	<p>On page 10.0 you can choose the language in which to display the messages.</p>
<p><b>Page 11.0</b></p> 	<p>On page 11.0 you can display the alarms log by pressing the right button.</p>

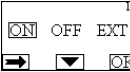
<p><b>Alarms Log</b></p> 	<p>If the system finds any faults it records them permanently in the alarms log (up to a maximum of 15 alarms). For each recorded alarm a page composed of 3 parts is displayed: an alphanumeric code that identifies the type of fault, a symbol that illustrates the fault in graphic mode, and a message in the language selected on Page 10.0, giving a brief description of the fault.</p> <p>By pressing the right button you can scroll through all the pages of the log.</p> <p>2 questions appear at the end of the log:  <b>"Reset Alarms?"</b>  Pressing OK (left button) resets any alarms still present in the system.  <b>"Delete Alarms Log?"</b>  Pressing OK (left button) deletes the alarms memorised in the log.</p>
<p><b>Pagina 12.0</b></p> 	<p>On page 12.0 you can set the system status in ON, OFF or controlled by a remote signal EXT (digital input IN1).</p> <p>If ON is selected the pump is always on.  If OFF is selected the pump is always off.  If EXT is selected, reading of the status of digital input IN1 is enabled. When input IN1 is energised the system goes ON and the pump is started (on the Home Page the messages "EXT" and "ON" appear alternately at bottom right); when input IN1 is not energised the system goes OFF and the pump goes off (on the Home Page the messages "EXT" and "OFF" appear alternately at bottom right).</p> <p>For the connection of the inputs see par. 6.2.1</p>

## 11. FACTORY SETTINGS

Parameter	Value
Regulating mode	= FL <sub>z</sub> portional differential pressure regulation
THs	50 °C
Operating mode	auto
Set-point reduction percentage	50 %
Type of external analogue signal	0-10V
Twin operating mode	②/①mate every 24h
Pump start control	EXT (from remote signal on input IN1).

Table 6: Factory settings

## 12. TYPES OF ALARM

Alarm Code	Alarm Symbol	Alarm Description
e0 - e16; e21		Internal Error
e17 - e19		Short Circuit
e20		Voltage Error
e22 - e31		Internal Error
e32 - e35		Electronic system excess temperature
e37		Low voltage
e38		High voltage
e39 - e40		Pump blocked
e43; e44; e45; e54		Pressure Sensor
e46		Pump Disconnected
e42		Dry operation
e56		Motor excess temperature (motor protector trips)
e57		Frequency of PWM external signal less than 100 Hz
e58		Frequency of PWM external signal greater than 5 kHz

Table 7: List of alarms



## INFORMATION

Frequently asked questions (faq) on the ecodesign directive 2009/125/ec establishing a framework for the setting of ecodesign requirements for energy-related products and its implementing regulations: [http://ec.europa.eu/enterprise/policies/sustainable-business/documents/eco-design/guidance/files/20110429\\_faq\\_en.pdf](http://ec.europa.eu/enterprise/policies/sustainable-business/documents/eco-design/guidance/files/20110429_faq_en.pdf)

Guidelines accompanying commission regulations implementing the ecodesign directive: [http://ec.europa.eu/energy/efficiency/ecodesign/legislation\\_en.htm](http://ec.europa.eu/energy/efficiency/ecodesign/legislation_en.htm) - see "circulators".

## 13. ERROR CONDITION AND RESET

Display indication		Description	Reset
e0 - e16		Internal error	<ul style="list-style-type: none"> <li>- Switch off system power.</li> <li>- Wait for the warning lights on the control panel to go off, then power the system again.</li> <li>- If the error persists, change the circulator.</li> </ul>
e37		Low mains voltage (LP)	<ul style="list-style-type: none"> <li>- Switch off system power.</li> <li>- Wait for the warning lights on the control panel to go off, then power the system again.</li> <li>- Check that the mains voltage is correct, if necessary reset it at the plate values</li> </ul>
e38		High mains voltage (HP)	<ul style="list-style-type: none"> <li>- Switch off system power.</li> <li>- Wait for the warning lights on the control panel to go off, then power the system again.</li> <li>- Check that the mains voltage is correct, if necessary reset it at the plate values.</li> </ul>
e32-e35		Critical overheating of electronic parts	<ul style="list-style-type: none"> <li>- Switch off system power.</li> <li>- Wait for the warning lights on the control panel to go off.</li> <li>- Check that the system ventilation ducts are not blocked and that the environment temperature of the premises is correct.</li> </ul>
e43-e45; e54		Sensor signal absent	<ul style="list-style-type: none"> <li>- Check sensor connection.</li> <li>- If the sensor is faulty, replace it.</li> </ul>
e39-e40		Protection against overcurrent	<ul style="list-style-type: none"> <li>- Check that the circulator turns freely.</li> <li>- Check that any antifreeze added does not exceed the maximum percentage of 30%.</li> </ul>
e21-e30		Voltage Error	<ul style="list-style-type: none"> <li>- Switch off system power.</li> <li>- Wait for the warning lights on the control panel to go off, then power the system again.</li> <li>- Check that the mains voltage is correct, if necessary reset it at the plate values.</li> </ul>
e31		Twin communication absent	<ul style="list-style-type: none"> <li>- Check that the twin communication cable is intact.</li> <li>- Check that both circulators are powered.</li> </ul>
e42		Dry operation	<ul style="list-style-type: none"> <li>- Put the system under pressure.</li> </ul>

e56		Motor excess temperature	<ul style="list-style-type: none"> <li>- Switch off system power.</li> <li>- Wait for the motor to cool down.</li> <li>- Power the system again.</li> </ul>
e57 ; e58		f < 100 Hz ; f > 5 kHz	Check that the PWM external signal is operating and connected as specified.

### Energy Efficiency Index - EEI

The benchmark for the most efficient circulators is  $EEI \leq 0,20$