

**ISTRUZIONI PER L'INSTALLAZIONE E LA MANUTENZIONE**  
**INSTRUCTIONS DE MISE EN SERVICE ET D'ENTRETIEN**  
**INSTRUCTIONS FOR INSTALLATION AND MAINTENANCE**  
**INSTALLATIONSANWEISUNG UND WARTUNG**  
**INSTRUCTIES VOOR INGEBRUIKNAME EN ONDERHOUD**  
**POKYNY K INŠTALÁCI A ÚDRŽBE**  
**ИНСТРУКЦИИ ПО МОНТАЖУ И ТЕХНИЧЕСКОМУ БСЛУЖИВАНИЮ**  
**KULLANIM VE BAKIM TALİMATLARI**  
**INSTALLATIONS - OCH UNDERHÅLLSANVISNING**  
**INSTRUCCIONES PARA LA INSTALACIÓN Y EL MANTENIMIENTO**  
**INSTRUÇÕES PARA A INSTALAÇÃO E A MANUTENÇÃO**  
**POKYNY K INSTALACI A ÚDRŽBĚ**  
**ASENNUS- JA HUOLTO-OHJEET**  
**INSTRUCTIUNI DE INSTALARE SI INTRETINERE**  
**INSTRUKCJA MONTAŻU I KONSERWACJI**  
**安装和维护说明**  
**إرشادات للتكيب والعناية.**  
**INSTALLÁCIÓS ÉS KARBANTARTÁSI KÉZIKÖNYV**  
**ИНСТРУКЦИЯ ЗА МОНТАЖ И ПОДРЪЖКА**

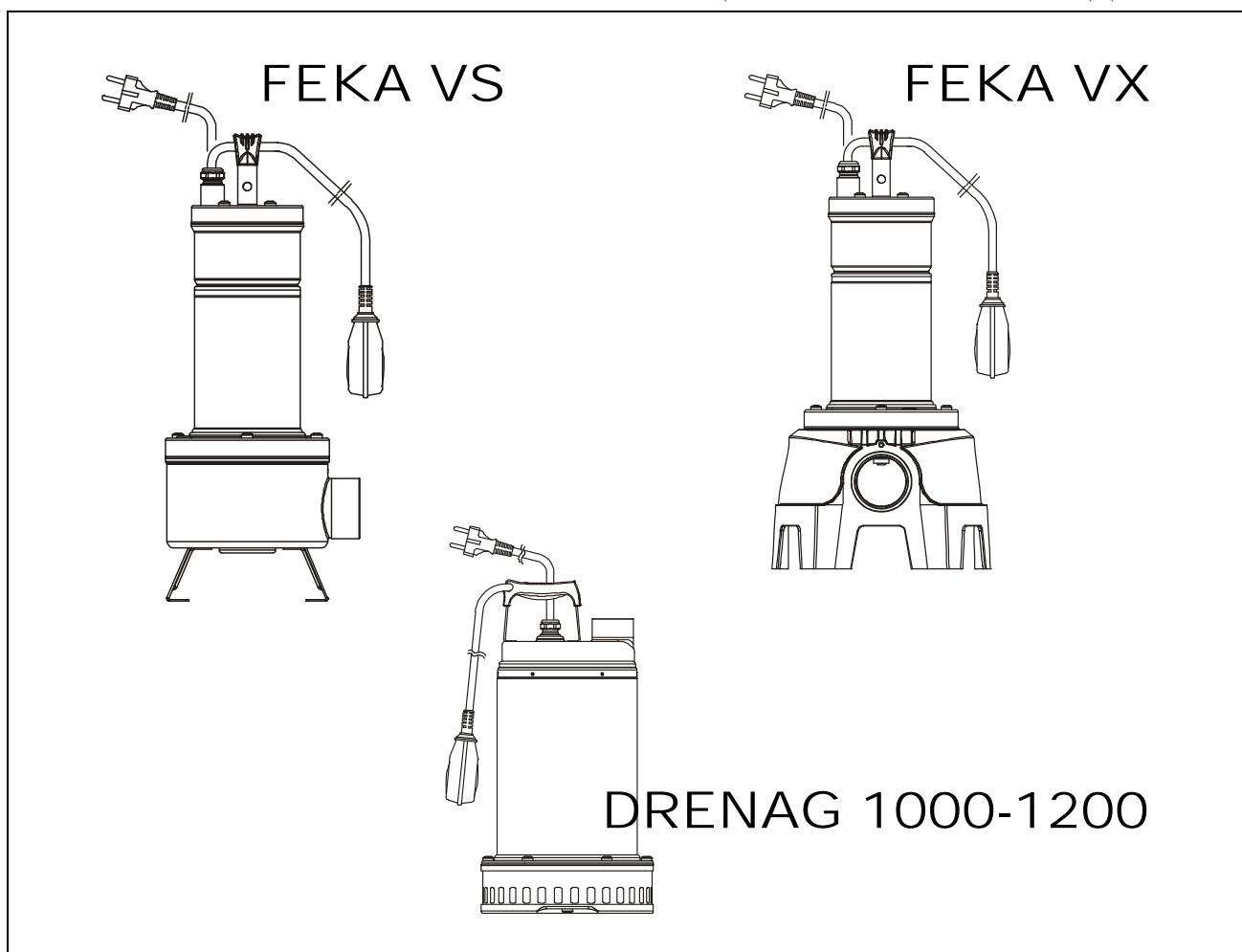

<b>ITALIANO</b>		<b>FRANÇAIS</b>	
Applicazioni	1	Applications	9
Dati tecnici e limitazioni d'uso	1	Caractéristiques techniques et limites d'utilisation	9
Avvertenze	2	Avertissements	10
Installazione	2	Installation	10
Installazione <i>FEKA VS-VX</i>	2	Installation <i>FEKA VS-VX</i>	10
Installazione <i>DRENAG 1000-1200</i>	3	Installation <i>DRENAG 1000-1200</i>	11
Allacciamento elettrico	4	Branchement électrique	12
Controllo del senso di rotazione (3 ~)	4	Contrôle du sens de rotation (3 ~)	12
Avviamento	5	Mise en marche	12
Regolazione dell'interruttore a galleggiante	5	Réglage de l'interrupteur à flotteur	12
Precauzioni	5	Précautions	13
Manutenzione e pulizia	5	Maintenance et lavage	13
Controllo e cambio olio tenuta <i>FEKA VS-VX</i>	6	Contrôle et vidange huile <i>FEKA VS-VX</i>	14
Controllo e cambio olio tenuta <i>DRENAG 1000-1200</i>	7	Contrôle et vidange huile <i>DRENAG 1000-1200</i>	15
Modifiche e parti di ricambio	8	Modifications et pièces de rechange	16
Ricerca e soluzioni inconvenienti	8	Identification des inconvénients et remèdes	16
<b>ENGLISH</b>		<b>DEUTSCH</b>	
Applications	17	Anwendungen	25
Technical data and limits on use	17	Technische Daten und Einsatzgrenzen	25
Warnings	18	Hinweise	26
Installation	18	Installation	26
Installation <i>FEKA VS-VX</i>	18	Installation <i>FEKA VS-VX</i>	26
Installation <i>DRENAG 1000-1200</i>	19	Installation <i>DRENAG 1000-1200</i>	27
Electric connection	20	Elektroanschluss	28
Checking the direction of rotation (3 ~)	20	Kontrolle der Drehrichtung (3 ~)	28
Starting up	20	Anlassen	29
Adjusting the float switch	20	Einstellen des Schwimmerschalters	29
Precautions	21	Vorsichtsmaßnahmen	29
Maintenance and cleaning	21	Wartung und Reinigung	29
Checking and changing the oil <i>FEKA VS-VX</i>	22	Kontrolle und Ölwechsel <i>FEKA VS-VX</i>	30
Checking and changing the oil <i>DRENAG 1000-1200</i>	23	Kontrolle und Ölwechsel <i>DRENAG 1000-1200</i>	31
Modifications and spare parts	24	Änderungen und Ersatzteile	32
Troubleshooting	24	Störungssuche und Abhilfen	32
<b>NEDERLANDS</b>		<b>SLOVENSKÝ JAZYK</b>	
Toepassingen	33	Použitie	41
Technische gegevens en instructie gebruik	33	Technické údaje a obmedzenie použitia	41
Waarschuwingen	34	Upozornenia	42
Installatie	34	Inštalácia	42
Installatie <i>FEKA VS-VX</i>	34	Inštalácia <i>FEKA VS-VX</i>	42
Installatie <i>DRENAG 1000-1200</i>	35	Inštalácia <i>DRENAG 1000-1200</i>	43
Elektrische aansluiting	36	Elektrické pripojenie	44
Controle draairichting (3 ~)	36	Kontrola smeru otáčania (3~)	44
Start	37	Spúšťanie	45
Bijstelling van de drijf vormige knop	37	Regulácia plavákového spínača	45
Voorzorgen	37	Bezpečnosté opatrenia	45
Schoonmaken en onderhoud	37	Údržba a čistenie	45
Controle en olie verversen <i>FEKA VS-VX</i>	38	Kontrola a výmena olejaü <i>FEKA VS-VX</i>	46
Controle en olie verversen <i>DRENAG 1000-1200</i>	39	Kontrola a výmena olejaü <i>DRENAG 1000-1200</i>	47
Veranderingen en wisselstukken	40	Úpravy a náhradné diely	48
Onderzoek en oplossing schade	40	Vyhľadávanie a odstraňovanie porúch	48

<b>РУССКИЙ</b>		<b>TÜRKÇE</b>	
Сферы применения	49	Kullanma şartları	57
Технические данные и ограничения в эксплуатации	49	Teknik bilgiler ve kullanım şartları	57
Предупреждения	50	Uyarılar	58
Монтаж	50	Montaj	58
Монтаж <i>FEKA VS-VX</i>	50	Montaj <i>FEKA VS-VX</i>	58
Монтаж <i>DRENAG 1000-1200</i>	51	Montaj <i>DRENAG 1000-1200</i>	59
Электропроводка	52	Elektrik bağlantısı	60
Проверка направления вращения (3 ~)	52	Dönme yönü kontrolü (3 fazlı)	60
Запуск	53	Çalıştırma	61
Регуляция поплавкового выключателя	53	Flatörlü su seviye şalterinin ayarlanması	61
Предосторожности	53	Önlemler	61
Техническое обслуживание и чистка	53	Bakım ve temizlik	61
Проверка и замена масла <i>FEKA VS-VX</i>	54	Salmastra yağı kontrol ve değiştirme <i>FEKA VS-VX</i>	62
Проверка и замена масла <i>DRENAG 1000-1200</i>	55	Salmastra yağı kontrol ve değiştirme <i>DRENAG 1000-1200</i>	63
Изменения и запасные части	56	Değişiklik ve yedek parçalar	64
Обнаружение и устранение неисправностей	56	Arıza araştırması	64
<b>SVENSKA</b>		<b>ESPAÑOL</b>	
Användningsområden	65	Aplicaciones	73
Tekniska data och användningsbegränsningar	65	Datos técnicos y límites de uso	73
Säkerhetsföreskrifter	66	Advertencias	74
Installation	66	Instalación	74
Installation <i>FEKA VS-VX</i>	66	Instalación <i>FEKA VS-VX</i>	74
Installation <i>DRENAG 1000-1200</i>	67	Instalación <i>DRENAG 1000-1200</i>	75
Elanslutning	68	Conexión eléctrica	76
Kontroll av rotationsriktning (trefas)	68	Control del sentido de rotación (3 ~)	76
Start	69	Puesta en marcha	77
Inställning av flottörbrytare	69	Regulación del interruptor de flotador	77
Försiktighetsåtgärder	69	Precauciones	77
Underhåll och rengöring	69	Mantenimiento y limpieza	77
Kontroll och byte av olja <i>FEKA VS-VX</i>	70	Control y cambio del aceite <i>FEKA VS-VX</i>	78
Kontroll och byte av olja <i>DRENAG 1000-1200</i>	71	Control y cambio del aceite <i>DRENAG 1000-1200</i>	79
Ändringar och reservdelar	72	Modificaciones y piezas de recambio	80
Felsökning och åtgärder	72	Búsqueda y soluciones de los inconvenientes	80
<b>PORTUGUÊS</b>		<b>ČESKÝ JAZYK</b>	
Aplicações	81	Použití	89
Dados técnicos e limites de utilização	81	Technické údaje a omezení použití	89
Advertências	82	Upozornění	90
Instalação	82	Instalace	90
Instalação <i>FEKA VS-VX</i>	82	Instalace <i>FEKA VS-VX</i>	90
Instalação <i>DRENAG 1000-1200</i>	83	Instalace <i>DRENAG 1000-1200</i>	91
Ligação eléctrica	84	Připojení k elektrické síti	91
Verificação do sentido de rotação (3 ~)	84	Kontrola směru otáčení (3 ~)	92
Arranque	85	Uvedení do provozu	92
Regulação do interruptor de bóia	85	Nastavení plovákového spínače	92
Precauções	85	Bezpečnostní opatření	93
Manutenção e limpeza	85	Údržba a čištění	93
Verificação e mudança do óleo <i>FEKA VS-VX</i>	86	Kontrola a výměna oleje u <i>FEKA VS-VX</i>	93
Verificação e mudança do óleo <i>DRENAG 1000-1200</i>	87	Kontrola a výměna oleje u <i>DRENAG 1000-1200</i>	94
Modificações e peças de reposição	88	Úpravy a náhradní díly	94
Procura e solução dos inconvenientes	88	Vyhledávání a odstranění poruch	95

## INSTRUCTIONS FOR INSTALLATION AND MAINTENANCE



Installation and functioning must comply with the safety regulations in force in the country in which the product is installed. The entire operation must be carried out in a workmanlike manner.

Failure to comply with the safety regulations not only causes risk to personal safety and damage to the equipment, but invalidates every right to assistance under guarantee.

### APPLICATIONS

The **FEKA VS-VX** pump is a submersible centrifugal pump made of stainless steel with a vortex back impeller, designed and built for use with dirty water from septic tanks and dirty water in general containing solid bodies with maximum diameter 50 mm, but only for non-aggressive water. Thanks to the radial delivery aperture (2" female) it may be easily fitted on lifting devices (type DSD2).

The float, where fitted, allows fixed installation and guarantees automatic pumping operation.

The **DRENAG 1000 - 1200** pump is of submersible centrifugal type, made completely of stainless steel with a clearance impeller, designed and built to pump clear waste water, sandy, muddy and sludgy waters, without fibre, containing solid bodies with maximum dimensions up to 10 mm in diameter, but always non-aggressive waters. Suitable for domestic and building-site uses in fixed applications, with manual or automatic operation, for draining cellars and garages prone to flooding, for pumping drains, rainwater traps or infiltrations from gutters, excavations, etc. Thanks to their compact shape and easy manoeuvrability and to the vertical delivery mouth with male thread, they are also suitable for particular applications as portable pumps for emergency uses, such as for drawing water from tanks or rivers, draining swimming pools or fountains, excavations or underpasses. Also suitable for gardening and hobby uses in general.

The float, where fitted, allows fixed installation and guarantees automatic pumping operation.



**These pumps cannot be used in swimming pools, ponds or tanks in which people or present, or for pumping hydrocarbons (petrol, diesel fuel, fuel oils, solvents, etc.) in accordance with the accident-prevention regulations in force.**

**N.B.** The liquid inside the pump, to lubricate the seal device, is not toxic but it may alter the characteristics of the water (if it is pure water) if there is a leak in the seal device.

### TECHNICAL DATA AND LIMITS ON USE

- |   |   |   |   |
|---|---|---|---|
| <ul style="list-style-type: none"> <li>- <b>Supply voltage:</b></li> <li>- <b>Flow rate:</b></li> <li>- <b>Hmax ( m ) - Head:</b></li> <li>- <b>Degree of motor protection:</b></li> <li>- <b>Protection class:</b></li> <li>- <b>Absorbed power:</b></li> <li>- <b>Liquid temperature range:</b></li> <li>- <b>Maximum immersion:</b></li> <li>- <b>Storage temperature:</b></li> <li>- <b>Noise level:</b></li> </ul> | <table border="0"> <tr> <td style="border-right: 1px solid black; padding-right: 10px;">           1 X 220/240V 50Hz<br/>           3 X 400V 50Hz<br/>           3 X 230V 50Hz         </td> <td style="padding-left: 10px;">           1 X 220/230V 60Hz<br/>           3 X 230V 60Hz<br/>           3 X 380/400V 60Hz         </td> </tr> </table> <ul style="list-style-type: none"> <li>see electric data plate</li> <li>pag. 152</li> <li>see electric data plate</li> <li>see electric data plate</li> <li>see electric data plate</li> <li>– from 0°C to +35°C for domestic use (safety standards EN 60335-2-41)</li> <li>– from 0°C to +50°C for other uses</li> <li>10 metres</li> <li>-10°C to +40°C</li> <li>Falls within the limits envisaged by EC Directive 89/392/EEC and subsequent modifications.</li> </ul> | 1 X 220/240V 50Hz<br>3 X 400V 50Hz<br>3 X 230V 50Hz | 1 X 220/230V 60Hz<br>3 X 230V 60Hz<br>3 X 380/400V 60Hz |
| 1 X 220/240V 50Hz<br>3 X 400V 50Hz<br>3 X 230V 50Hz   | 1 X 220/230V 60Hz<br>3 X 230V 60Hz<br>3 X 380/400V 60Hz   |   |   |

**WARNINGS**

1. Use is allowed only if the electric system is in possession of safety precautions in accordance with the regulations in force.
2. The pump is provided with a carrying handle which may also be used to lower it into wells or deep holes with a rope or cable.



**The pumps must never be carried, lifted or made to operate hanging from their power cable.**

3. If the power cable is damaged in any way it must be **replaced** and **not repaired** (use cable type H07RN-F diam. 9 – 9.5 mm. with minimum length 10 metres for the portable version, with a UNEL 47166-68 plug for the SINGLE-PHASE version and with an EEC plug for the THREE-PHASE version). This must be done by skilled personnel, in possession of the qualifications required by the regulations in force.
4. Qualified personnel must also be employed for all electrical repairs which, if badly carried out, could cause damage and accidents.
5. The pump must **never** be allowed to run dry.
6. The Manufacturer does not vouch for correct operation of the pump if it is tampered with or modified.

**INSTALLATION**

1. If the bottom of the well or borehole in which the pump is to operate is particularly dirty, it is advisable to provide a support for the pump to sit on so as to avoid clogging of the intake grid. (**Fig. 1-Fig.3**).
2. Before putting the pump in position, ensure that the strainer is not totally or partially blocked by mud, sediment or similar substances.
3. It is advisable to use pipes with an internal diameter at least equal to that of the delivery mouth, to avoid falls in pump performance and the possibility of clogging. In cases where the delivery pipe has long horizontal stretches, it is advisable for this pipe to have a larger diameter than that of the delivery mouth.
- 4.



**Totally immerse the pump in the water.**

**INSTALLATION FEKA VS-VX**

1. On the version provided with a float switch, ensure that the float can move freely (SEE THE PARAGRAPH ON ADJUSTING THE FLOAT SWITCH). Ensure that the **minimum dimensions** of the borehole are as in **Fig.1**. The dimensions of the borehole must also be calculated with relation to the quantity of water arriving and to the pump flow rate so as not to subject the motor to excessive starting operations.
2. When the pump is to be in a fixed installation, with a float, a check valve must always be fitted in the delivery pipe. This is also advisable on pumps with manual operation.

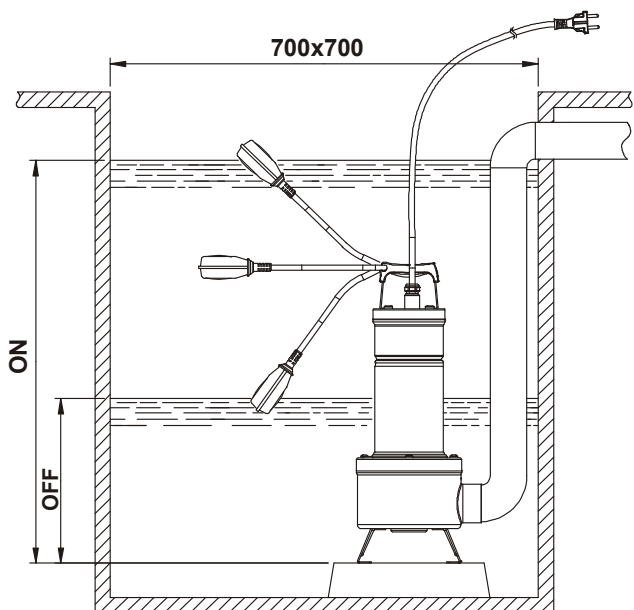

**(Fig.1)**

3. Connect the delivery pipe or hose directly to the pump mouth. If the pump is used in fixed installations it is advisable to connect it to the pipe with a coupling so as to facilitate disassembly and reinstallation. If a hose is used, fit a threaded hosetail on the pump mouth. Wrap the thread with suitable material to ensure an effective seal (teflon tape or similar).

4. For fixed installations we advise the use of the lifting device DSD2 (available on request - **Fig.2**) to facilitate pump maintenance operations. When fitted between the pump delivery aperture and the pipe, it avoids having to remove the delivery pipe during maintenance jobs. The DSD2 device is composed of 8 parts:

- A. Pipe anchoring bracket
- B. 3/4" pipes (not supplied)
- C. Slide
- D. Pipe guide columns
- E. Foot
- F. Screw TCEI M10X25
- G. Base bracket
- H. Nut M10
- I. Pump flange screw
- L. Pump

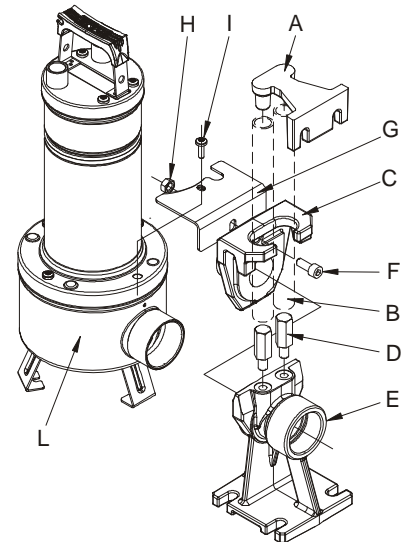

**(Fig.2)**

The foot is positioned on the bottom of the tank and fixed with expansion screws of suitable dimensions. The pipe guide bracket must be positioned at the top of well or borehole and inserted in the end of two 3/4" pipes (not supplied), which act as a slide. The two pipes connect the bracket to the foot. Position the base bracket in contact with the pump suction strainer near the delivery aperture, secure everything to the strainer cover with the screws provided to lock the strainer cover.

Remove the top screw from the flange on the delivery side ( I ).

Assemble the anti-rotation bracket ( G ).

Replace the screw ( I ).

Extract the slide from the coupling foot and connect it to the delivery port of the pump.

Using the screw F and the nut H, fix the slide to the pump as indicated in the figure.

Reposition the slide/pump assembly on the foot (**Fig.2**).

### **INSTALLATION DRENAG 1000-1200**

1. Connect the delivery pipe or hose directly to the pump mouth. If the pump is used in fixed installations it is advisable to connect it to the pipe with a coupling so as to facilitate disassembly and reinstallation. If a hose is used, fit a threaded hosetail on the pump mouth. Wrap the thread with suitable material to ensure an effective seal (teflon tape or similar).
2. On the version provided with a float switch, ensure that the float can move freely (SEE THE PARAGRAPH ON ADJUSTING THE FLOAT SWITCH). Ensure that the **minimum dimensions** of the borehole are as in **Fig.3**. The dimensions of the borehole must also be calculated with relation to the quantity of water arriving and to the pump flow rate so as not to subject the motor to excessive starting operations.

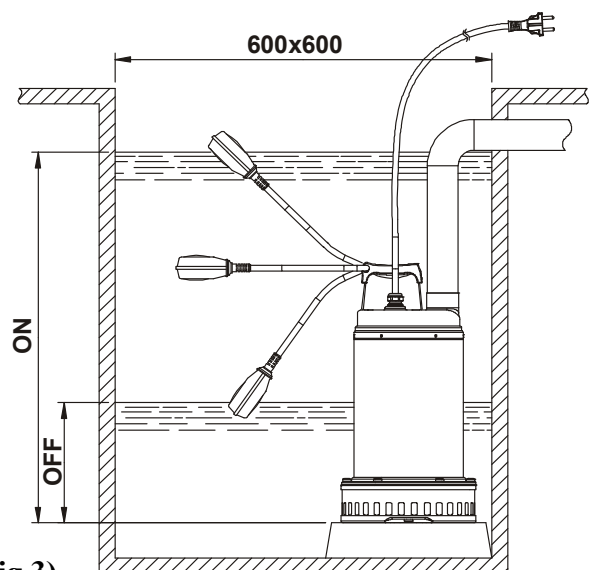

**(Fig.3)**

3. When the pump is to be in a fixed installation, with a float, a check valve must always be fitted in the delivery pipe. This is also advisable on pumps with manual operation.

**ELECTRIC CONNECTION****CAUTION! ALWAYS FOLLOW THE SAFETY REGULATIONS.**

1. Use is allowed only if the electric system is in possession of safety precautions in accordance with the regulations in force.
2. Ensure that the mains voltage is the same as the value shown on the motor plate and that there is the possibility of **MAKING A GOOD EARTH CONNECTION**.
3. **Pumping stations must always be provided with an automatic switch with an intervention current of less than 30 mA.**
4. Single-phase motors are provided with built-in thermal overload protection and may be connected directly to the mains. **N.B.** If the motor is overloaded it stops automatically. **Once it has cooled down it starts again automatically without any need for manual intervention.**
5. Three-phase pumps must be protected with motor protectors suitably calibrated according to the values on the data plate of the pump to be installed. The plug on the pump must be connected to an EEC socket complete with isolating switch and fuses.
6. Do not damage or cut the power cable. If this should occur accidentally, have it repaired or replaced by skilled and qualified personnel.

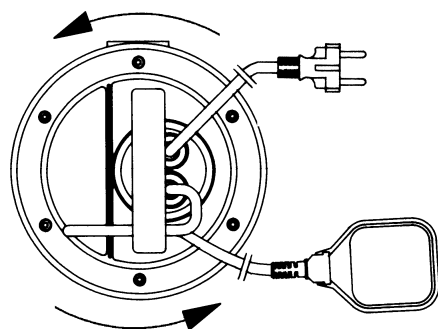
**CHECKING THE DIRECTION OF ROTATION (for three-phase motors)****(Fig.4)**

The direction of rotation must be checked each time a new installation is made.

Proceed as follows **(Fig.4)**:

1. Place the pump on a flat surface.
2. Start the pump and stop it immediately.
3. Carefully observe the kick-back on starting, looking at the pump from the motor side. The direction of rotation is correct, that is clockwise, if the protection cap moves as in the drawing (anti-clockwise).

If it is not possible to check as described above because the pump is already installed, check as follows:

1. Start the pump and observe the water flow rate.
2. Stop the pump, switch off the power and invert two phases on the supply line.
3. Restart the pump and check the water flow rate again.
4. Stop the pump.



**The correct direction of rotation will be the one in which the flow rate and electric absorption are LOWER!**

**STARTING UP**

Models with a float switch start up automatically when the water level rises; models without a float are started by means of a switch located upstream from the socket (not supplied).

**ADJUSTING THE FLOAT SWITCH**

Lengthening or shortening the cable between the float and the fixed point (slot provided in the handle - **Fig.5**) adjusts the **START** or **STOP** level of the pump. Be sure that the float can move freely.



**DRENAG** → Ensure that the stop level does not uncover the strainer.  
**FEKA VS-VX 550-750** → Minimum stopping level 370mm from the bottom.  
**FEKA VS-VX 1000-1200** → Minimum stopping level 400mm from the bottom.

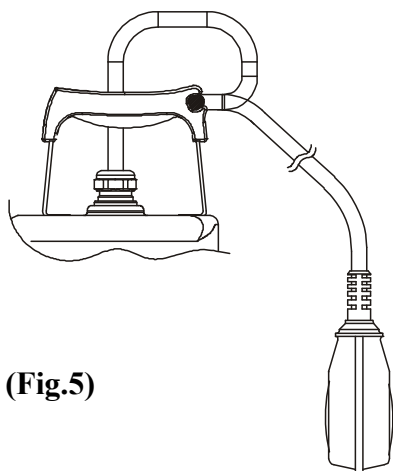

(Fig.5)

### PRECAUTIONS

1. The intake strainer must always be in place during pump operation.
2. The pump should not be started more than 20 times in one hour so as not to subject the motor to excessive thermal shock.
3. **DANGER OF FROST:** When the pump remains inactive for a long time at temperatures of less than 0°C, it is necessary to ensure that there is no water residue which could freeze and cause cracking of the pump components.
4. If the pump has been used with substances which tend to form a deposit, rinse it after use with a powerful jet of water so as to avoid the formation of deposits or scale which would tend to reduce the yield of the pump.

### MAINTENANCE AND CLEANING



In normal operation, the pump does not require any specific maintenance, thanks to its mechanical seal lubricated in an oil chamber and to its sealed-for-life bearings. **The electropump must not be dismantled unless by skilled personnel in possession of the qualifications required by the regulations in force.** In any case, all repairs and maintenance jobs must be carried out only after having disconnected the pump from the power mains.

During disassembly, pay attention to any sharp parts which could cause injury.



**CHECKING AND CHANGING THE SEALING OIL *FEKA VS-VX***

To perform this operation, slacken the six screws (45) so as to be able to remove the strainer cover, the strainer and the pump body (1). Retain the O-ring (28) and the nuts (51). Using a suitable spanner, unscrew the impeller retaining nut (18), holding the impeller (4) still with your hand. Retain the key (17) and the sand guard (15). Now overturn the pump with the hydraulic part facing upwards, unscrew and remove the drainage cap (64).

Tilt the pump so as to let the oil flow out of the drainage hole (64) and catch it in a container. Analyse the oil: if you find any particles of water or abrasive materials (for example, sand) it is advisable to check the condition of the mechanical seal (16) and to have it changed if necessary (at a specialized centre). In this case change the oil too, with **about 170 gr of oil type MARCOL 152ESSO**.

Top up the oil level inside the sealing oil chamber using a special funnel inserted in the hole in the cap (64). Screw the drainage cap (64) back on and perform the disassembly operations in inverse order to reassemble the pump after having spread a suitable amount of teflon grease in the seat of the sand guard (15).

**OLD OIL MUST BE DISPOSED OF AS REQUIRED BY THE REGULATIONS IN FORCE.**

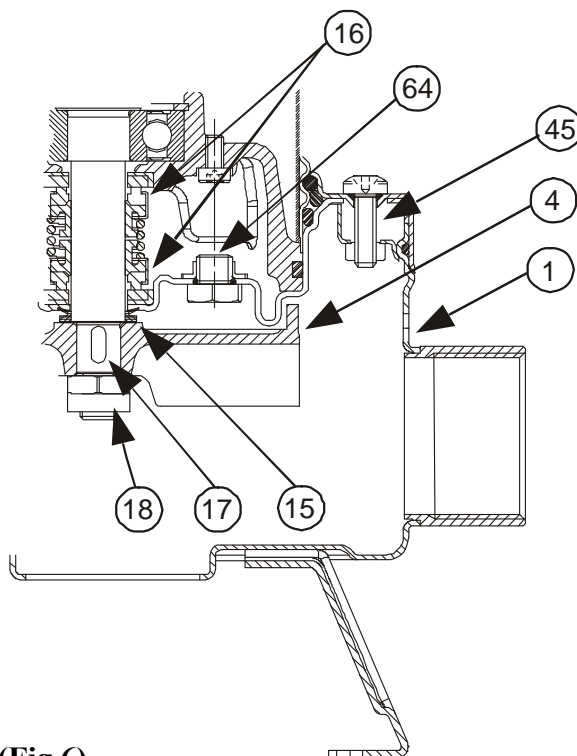

**(Fig.6)**

**CHECKING AND CHANGING THE SEALING OIL *DRENAG 1000-1200***

To perform this operation you must unscrew the six screws of the flange (45) so as to be able to remove the flange (105) and the outer jacket (77). Unscrew the three screws of the filter cover (136) and remove the cover (92) and the filter (42). Unscrew the four screws of the pump body (52) and remove the pump body (1). Using a suitable wrench, unscrew the nut (18) that blocks the impeller, holding the impeller (4) still with your hand. Remove the impeller (4), if necessary with the aid of levers. Recover the tab (17) and the sand protection ring (15), unscrew and remove the cap (64). Tilt the pump so as to drain the oil out of the hole of the cap (64) and pour it into a container. Analyse the oil: if you find any particles of water or abrasive materials (for example, sand) it is advisable to check the condition of the mechanical seal (16) and to have it changed if necessary (at a specialized centre). In this case change the oil too, with **about 170 gr of oil type MARCOL 152 ESSO**.

Top up the oil level inside the sealing oil chamber using a special funnel inserted in the hole in the cap (64). Screw the drainage cap (64) back on and perform the disassembly operations in inverse order to reassemble the pump after having spread a suitable amount of teflon grease in the seat of the sand guard (15).

**Attention! During assembly, fit all the O-rings correctly, without damaging them.**

**OLD OIL MUST BE DISPOSED OF AS REQUIRED BY THE REGULATIONS IN FORCE.**

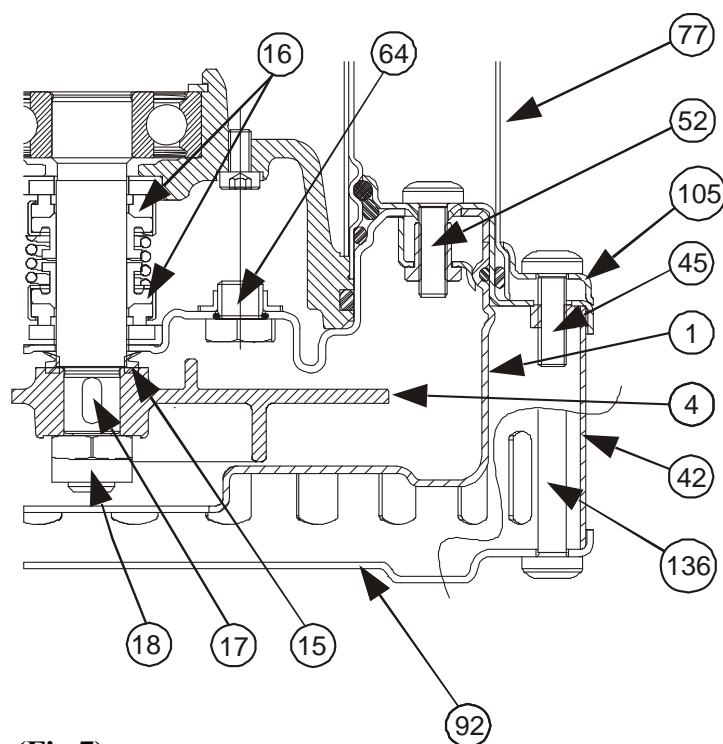

**(Fig.7)**

**MODIFICATIONS AND SPARE PARTS**

**Any modification not authorized beforehand relieves the manufacturer of all responsibility. All the spare parts used in repairs must be original ones and the accessories must be approved by the manufacturer so as to be able to guarantee maximum safety of the machines and systems in which they may be fitted.**

The manufacturer declines all responsibility for possible errors in this booklet, if due to misprints or errors in copying. The company reserves the right to make any modifications to products that it may consider necessary or useful, without affecting the essential characteristics.

**TROUBLESHOOTING**

<b>FAULT</b>	<b>CHECK (possible cause)</b>	<b>REMEDY</b>
1. The motor does not start and makes no noise.	A. Check that the motor is live. B. Check the protection fuses. C. The float switch does not allow starting.	B. If they are burnt-out, change them. C. -Ensure that the float moves freely. -Ensure that the float is efficient (contact the supplier).
2. The pump does not deliver.	A. The intake grid or the pipes are blocked. B. The impeller is worn or blocked. C. The check valve, if installed on the delivery pipe, is blocked in closed position. D. The level of the liquid is too low. When starting, the level of the liquid must be higher than that of the strainer. E. The required head is higher than the pump characteristics.	A. Remove the blockage. B. Change the impeller or remove the blockage. C. Check that the valve is operating correctly and replace it if necessary. D. Adjust the length of the float switch cable (SEE THE PARAGRAPH ON "ADJUSTING THE FLOAT SWITCH").
3. The pump does not stop.	A. The switch is not deactivated by the float.	A. -Ensure that the float moves freely. -Check float efficiency (the contacts could be damaged - contact the supplier).
4. The flow is insufficient.	A. Ensure that the intake grid is not partly blocked. B. Ensure that the impeller or the delivery pipe are not partly blocked or encrusted. C. Ensure that the impeller is not worn. D. Ensure that the check valve (if fitted) is not partly clogged. E. On three-phase motors, check that the direction of rotation is correct (See the paragraph on "CHECKING THE DIRECTION OF ROTATION").	A. Remove any blockage. B. Remove any blockage. C. Change the impeller. D. Carefully clean the check valve. E. Invert the connection of two supply wires.
5. The thermal overload protection stops the pump.	A. Check that the liquid to be pumped is not too dense as this could cause overheating of the motor. B. Check that the water temperature is not too high. C. The pump is partly blocked by impurities. D. The pump is mechanically blocked.	C. Carefully clean the pump. D. Check whether there is rubbing between the moving and fixed parts; check the wear of the bearings (contact the supplier).