

ISTRUZIONI PER L'INSTALLAZIONE E LA MANUTENZIONE (IT)  
INSTRUCTIONS FOR INSTALLATION AND MAINTENANCE (GB)  
INSTRUCTIONS POUR L'INSTALLATION ET LA MAINTENANCE (FR)  
INSTALLATIONS- UND WARTUNGSANLEITUNGEN (DE)  
INSTRUCTIES VOOR INSTALLATIE EN ONDERHOUD (NL)  
INSTRUCCIONES DE INSTALACIÓN Y MANTENIMIENTO (ES)  
ІНСТРУКЦІЇ ПО МОНТАЖУ І ТЕХОБСЛУЖИВАННЮ (RU)  
ASENNUS- JA HUOLTO-OHJEET (FI)  
INSTRUCTIUNI PENTRU INSTALARE SI INTRETINERE (RO)  
INSTRUKCJA MONTAŻU I KONSERWACJI (PL)  
ΟΔΗΓΙΕΣ ΓΙΑ ΤΗΝ ΕΓΚΑΤΑΣΤΑΣΗ ΚΑΙ ΤΗ ΣΥΝΤΗΡΗΣΗ (GR)  
INSTALLÁCIÓS ÉS KARBANTARTÁSI KÉZIKÖNYV (HU)  
NÁVOD K INSTALACI A ÚDRŽBĚ (CZ)  
ІНСТРУКЦІЇ З МОНТАЖУ ТА ТЕХНІЧНОГО ОБСЛУГОВУВАННЯ (UA)

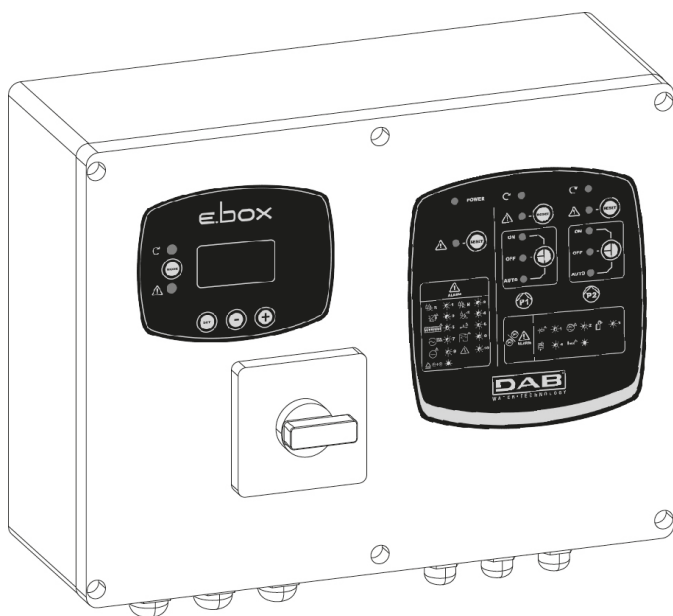

**E.Box Plus**

**E.Box Plus D**

**E.Box Basic**

**E.Box Basic D**



<b>ITALIANO</b>	Pag.	1
<b>ENGLISH</b>	Pag.	59
<b>FRANÇAIS</b>	Page	117
<b>DEUTSCH</b>	Seite	175
<b>NEDERLANDS</b>	Pag.	233
<b>ESPAÑOL</b>	Pág.	291
<b>РУССКИЙ</b>	Стр.	349
<b>SUOMI</b>	Sivu	407
<b>ROMÂNĂ</b>	Pag.	464
<b>POLSKI</b>	Str.	522
<b>ΕΛΛΗΝΙΚΑ</b>	Σελ.	580
<b>MAGYAR</b>	Oldal	640
<b>ČEŠTINA</b>	Str.	700
<b>УКРАЇНСЬКА</b>	стор.	758

**INDEX**

<b>KEY</b> .....	<b>64</b>
<b>WARNINGS</b> .....	<b>64</b>
<b>RESPONSIBILITY</b> .....	<b>64</b>
<b>1 GENERAL</b> .....	<b>64</b>
<b>1.1 Technical characteristics</b> .....	<b>65</b>
<b>1.2 Protections</b> .....	<b>65</b>
<b>2 INSTALLATION</b> .....	<b>65</b>
<b>2.1 Electrical connections</b> .....	<b>66</b>
2.1.1 Instrumental checks to be carried out by the installer.....	66
2.1.2 Boards and connections .....	67
<b>2.2 Electrical connection of the pumps</b> .....	<b>69</b>
Connection of three-phase pumps.....	69
Connection of single-phase pumps with internal capacitor.....	69
Connection of single-phase pumps with external capacitor.....	69
<b>2.3 Power supply electrical connection</b> .....	<b>70</b>
<b>3 FRONT PANEL</b> .....	<b>71</b>
<b>4 PANEL INTERNAL REGULATING BOARD</b> .....	<b>72</b>
<b>4.1 Trimmer for regulating the system (I<sub>max</sub> – SP – DP)</b> .....	<b>72</b>
<b>4.2 Dip-switch for selecting functions (DS_A – DS_B)</b> .....	<b>73</b>
<b>5 PRESSURE BOOSTING FUNCTION</b> .....	<b>73</b>
<b>5.1 Expansion vessel</b> .....	<b>73</b>
<b>5.2 Electrical connections of pump and supply</b> .....	<b>73</b>
<b>5.3 Connection of additional protections: high pressure, low pressure and motor thermal protection</b> .....	<b>74</b>
<b>5.4 Connection of the alarm outputs</b> .....	<b>74</b>
<b>5.5 Operation with pressure sensor (recommended choice)</b> .....	<b>75</b>
<b>5.6 Connection of the pressure sensor</b> .....	<b>75</b>
<b>5.7 Operation with pressure switches</b> .....	<b>75</b>
<b>5.8 Setting with the display, wizard</b> .....	<b>75</b>
<b>5.9 Setting with a pressure sensor</b> .....	<b>76</b>
<b>5.10 Configuration with pressure switches</b> .....	<b>77</b>
<b>5.11 Setting the E.box with dip switches</b> .....	<b>77</b>
<b>5.12 Activation of the set</b> .....	<b>78</b>
<b>5.13 Regulating the rated current of the pumps (I<sub>max</sub>), Set point (SP) and differential restarting pressure (DP)</b> .....	<b>78</b>
<b>5.14 System operation</b> .....	<b>78</b>
Pressure switches:.....	78
Pressure sensor:.....	79
<b>6 FILLING FUNCTION</b> .....	<b>80</b>
<b>6.1 Electrical connections of pump and supply</b> .....	<b>80</b>
<b>6.2 Control inputs</b> .....	<b>80</b>
<b>6.3 Connection of additional protections: overflow, water lack, motor thermal protection</b> .....	<b>80</b>
<b>6.4 Connection of the alarm outputs</b> .....	<b>81</b>
<b>6.5 Connection of floats or level probes</b> .....	<b>82</b>
<b>6.6 Depth sensor connection</b> .....	<b>82</b>
<b>6.7 Setting with the display, wizard</b> .....	<b>82</b>
<b>6.8 Configuration of floats or level probes</b> .....	<b>83</b>
<b>6.9 Configuration with a depth sensor</b> .....	<b>84</b>
<b>6.10 Setting the E.box with dip switches</b> .....	<b>85</b>
<b>6.11 Activation of the set</b> .....	<b>85</b>
<b>6.12 Regulating the rated current of the pumps (I<sub>max</sub>) and the pump starting and stopping levels (only with depth sensor connected)</b> .....	<b>85</b>
<b>6.13 System operation:</b> .....	<b>86</b>
Operation with 2 floats or level probes.....	86
Operation with 3 floats or level probes.....	86
Operation with depth sensor and display.....	86
Operation with depth sensor without display .....	86
<b>7 Draining function</b> .....	<b>88</b>
<b>7.1 Electrical connections of pump and supply</b> .....	<b>88</b>
<b>7.2 Control inputs</b> .....	<b>88</b>
<b>7.3 Connection of additional protections: overflow, water lack, motor thermal protection</b> .....	<b>88</b>
<b>7.4 Connection of the alarm outputs</b> .....	<b>89</b>

7.5	Connection of floats or level probes .....	90
7.6	Depth sensor connection .....	90
7.7	Setting with the display, wizard .....	90
7.8	Configuration of floats or level probes .....	91
7.9	Configuration with a depth sensor .....	92
7.10	Setting the E.box with dip switches .....	93
7.11	Activation of the set .....	93
7.12	Regulating the rated current of the pumps (I <sub>max</sub> ) and the pump starting and stopping levels (only with depth sensor connected) .....	94
7.13	<b>System operation:</b> .....	94
	Operation with 2 floats or level probes.....	94
	Operation with 3 floats or level probes.....	94
	Operation with depth sensor and display.....	94
	Operation with depth sensor without display .....	95
8	<b>KIWA PRESSURE BOOSTING FUNCTION</b> .....	95
8.1	Expansion vessel.....	95
8.2	Electrical connections of pump and supply .....	95
8.3	Connection of additional protections: high pressure and motor thermal protection .....	95
8.4	Connection of the alarm outputs .....	96
8.5	Operation with pressure sensor (recommended choice).....	96
8.6	Connection of the pressure sensor.....	96
8.7	Operation with pressure switches.....	97
8.8	Connection of pressure switches.....	97
8.9	Connecting the low-pressure pressure switch .....	97
8.10	Setting with the display, wizard.....	97
8.11	Setting with a pressure sensor:.....	98
8.12	Configuration with pressure switches:.....	98
8.13	System status in Kiwa mode.....	99
8.14	Setting the E.box with dip switches .....	99
8.15	Activation of the set.....	99
8.16	Regulating the rated current of the pumps (I <sub>max</sub> ), Set point (SP) and differential restarting pressure (DP) .....	100
8.17	<b>System operation</b> .....	100
	Pressure switches:.....	100
	Pressure sensor:.....	100
9	<b>THE KEYPAD AND THE DISPLAY</b> .....	102
9.1	<b>Status line</b> .....	103
9.2	<b>Menus</b> .....	103
9.3	<b>Access to the menus</b> .....	103
	Direct access with a combination of keys .....	103
	Access by name with a drop-down menu .....	105
9.4	<b>MEANING OF THE INDIVIDUAL PARAMETERS</b> .....	105
9.4.1	<b>USER MENU</b> .....	105
	VP: Pressure display .....	105
	C1: Display of the phase current of pump P1 .....	105
	C2: Display of the phase current of pump P2 .....	105
	PO1: Display of the power absorbed by pump P1 .....	105
	PO2: Display of the power absorbed by pump P2 .....	105
	VE: System monitor .....	105
	SN: Serial 105 .....	
9.4.2	<b>MONITOR MENU</b> .....	105
	FF: Fault log display .....	106
	CT: Display contrast .....	106
	LA: Language .....	106
	HS: System operating hours .....	106
	H1: Pump P1 operating hours .....	106
	H2: Pump P2 operating hours .....	106
9.4.3	<b>SETPOINT MENU</b> .....	106
	SP: Setting the Set Point pressure (only in pressure boosting and in KIWA pressure boosting with pressure sensor) .....	106
	RP: Setting the Pressure Differential (only in pressure boosting and in KIWA pressure boosting with pressure sensor).....	106
	HC: Pump P2 starting level (only in drainage or filling with depth sensor) .....	106

ENGLISH

HB: Pump P1 starting level (only in drainage or filling with depth sensor).....	106
HA: Pumps stopping level (only in drainage or filling with depth sensor) .....	106
<b>9.4.4 INSTALLER MENU .....</b>	<b>106</b>
RC: Setting the rated current of the electropump .....	107
MF: Operating mode .....	107
MC: Control devices .....	107
GS: Protection devices (only in drainage or filling or with depth sensor).....	107
PR: Type of sensor used (only if a pressure or depth sensor is used) .....	107
MS: Measuring system .....	107
SO: Dry running factor .....	107
MP: Minimum pressure threshold (only in pressure boosting and KIWA pressure boosting) .....	107
OD: Expansion vessel size (only in pressure boosting and KIWA pressure boosting) .....	107
EP: Pump exclusion.....	107
<b>9.4.5 TECHNICAL ASSISTANCE MENU .....</b>	<b>107</b>
TB: Water lack blockage time .....	107
T1: Switch-off time after the low pressure signal (only in pressure boosting and KIWA pressure boosting) .....	107
T2: Switch-off delay time (only in KIWA pressure boosting) .....	107
ET: Exchange mode .....	107
AL: Anti-leakage .....	108
AB: Anti-blocking (only in drainage).....	108
TH: Tank height (only in filling or drainage mode with a depth sensor).....	108
ML: Maximum level alarm (only in filling or drainage mode with a depth sensor).....	108
LL: Minimum level alarm (only in filling or drainage mode with a depth sensor).....	108
PS: Power supply system (can be changed only on EBOX plus with 230V power supply) .....	108
RF: Reset fault & warning .....	108
PW: Setting the password .....	108
<b>10 PANEL PROTECTIONS AND ALARMS.....</b>	<b>108</b>
<b>10.1 Errors indicated by alarm leds and relays.....</b>	<b>108</b>
<b>10.2 Digital inputs R and N protection /alarm.....</b>	<b>110</b>
- Relay/remote control switch alarm.....	111
- Pump disconnected .....	111
- Dry running protection/alarm .....	111
- Protection against too frequent starts .....	111
- Current overload protection/alarm (overload protection) .....	111
- Pressure or depth sensor alarm .....	111
- Floats and/or probes incoherence alarm .....	111
- Dip-Switch alarm.....	111
- Error alarm.....	111
- Input voltage .....	111
- Voltage selector error .....	112
- Voltage Error .....	112
- Internal error .....	112
- General pump error P1 + P2 .....	112
<b>10.3 Alarms shown on the display .....</b>	<b>112</b>
<b>10.3.1 Alarms indicated on the display.....</b>	<b>112</b>
- JR: Relay/remote control switch stuck alarm.....	113
- NC: Pump Disconnected .....	113
- BL: Dry running protection/alarm .....	113
- LK: Protection against too frequent starts.....	114
- OC: Current overload protection/alarm (overload protection).....	114
- RI: RI alarms.....	114
- NI: NI alarms.....	114
- HL: Maximum level alarm .....	115
- LL: Minimum level alarm.....	115
- BP1/BP2: Pressure sensor / depth sensor alarm .....	115
- FI: Floats or level probes state incoherence.....	115
- DS: Dip Switch alarm.....	115
- W1: Trimmer SP .....	115
- W2: Trimmer DP .....	115
- W3: Trimmer lmax .....	115
- PK: Key error .....	115

- NL: Input voltage error .....	115
- VS: Voltage selector error.....	115
- V0..V15: Voltage error .....	116
- OM: Changed operating mode .....	116
- E0..E15: Internal error .....	116
<b>11 RESET AND FACTORY SETTINGS.....</b>	<b>116</b>
<b>11.1 General system reset.....</b>	<b>116</b>
<b>11.2 Restoring the factory settings .....</b>	<b>116</b>

**INDEX OF TABLES**

Table 1: Technical data .....	65
Table 2: Pressure boosting operation with pressure switches.....	78
Table 3: Pressure boosting operation standard vessel < 100 litres.....	79
Table 4: Operation with additional expansion vessel > 100 litres.....	79
Table 5: Filling operation with 2 floats .....	86
Table 6: Filling operation with 3 floats .....	86
Table 7: Operation with depth sensor, without display .....	87
Table 8: Filling operation with 2 floats .....	94
Table 9: Filling operation with 3 floats .....	94
Table 10: Drainage with depth sensor, without display .....	95
Table 11: Pressure boosting operation with pressure switches.....	100
Table 12: Pressure boosting operation standard vessel < 100 litres.....	101
Table 13: Operation with additional expansion vessel > 100 litres.....	101
Table 14: Key functions .....	103
Table 15: Access to the menus .....	104
Table 16: Menu structure.....	105
Table 17: General table of alarms: signals and contacts.....	110
Table 18: Digital inputs R and N protection /alarm .....	110
Table 19: E.Box errors shown on the display .....	113
Table 20: RI alarms .....	114
Table 21: NI alarms .....	115

**INDEX OF FIGURES**

Figure 1: E.box Basic Board .....	67
Figure 2: E.Box Plus Board .....	68
Figure 3: Electrical connection of pumps.....	69
Figure 4: Connection of pump external capacitors .....	70
Figure 5: Electrical connection to the supply line.....	70
Figure 6: Display label, present only on plus models .....	71
Figure 7: Front label.....	71
Figure 8: Inputs and outputs .....	74
Figure 9: Thermal protection inputs KK .....	74
Figure 10: Pressure sensor connection 4..20mA.....	75
Figure 11: Terminals for connecting the pressure switches .....	75
Figure 12: Configuration with a pressure sensor .....	76
Figure 13: Configuration with pressure switches .....	77
Figure 14: Dip switches for pressure boosting.....	77
Figure 15: Enabling P1 and P2.....	78
Figure 16: Regulating: I <sub>max</sub> , SP and DP.....	78
Figure 17: Regulation with expansion vessel < 100 litres.....	79
Figure 18: Regulation with expansion vessel > 100 litres.....	79
Figure 19: Diagram of filling system inputs.....	80
Figure 20: Inputs and protections .....	81
Figure 21: Thermal protection inputs KK .....	81
Figure 22: Inputs.....	82
Figure 23: Depth sensor connection.....	82
Figure 24: Configuration of Filling with floats or level probes .....	83
Figure 25: System status in filling mode, with floats or level probes as control inputs.....	83
Figure 26: A System status with depth sensor only, B depth sensor and floats, C depth sensor and level probes .....	84
Figure 27: Setting the filling dip switches.....	85
Figure 28: Enabling P1 and P2.....	85

ENGLISH

Figure 29: Regulating the rated current SP and DP .....	86
Figure 30: Filling with a depth sensor .....	87
Figure 31: Draining system diagram .....	88
Figure 32: Position of inputs and alarms .....	89
Figure 33: Thermal protection inputs KK .....	89
Figure 34: Inputs .....	90
Figure 35: Depth sensor connection .....	90
Figure 36: Configuration of Drainage floats or level probes .....	91
Figure 37: System status in drainage mode, A with level probes. B with floats .....	91
Figure 38: Configuration with only a depth sensor .....	92
Figure 39: System status in configurations: A with only depth sensor, B: depth sensor and floats, C depth sensor and level probes .....	93
Figure 40: Setting the Drainage dip switches .....	93
Figure 41: Enabling P1 and P2 .....	93
Figure 42: Regulating the rated current SP and DP .....	94
Figure 43: Drainage with a depth sensor .....	95
Figure 44: Inputs .....	96
Figure 45: Thermal protection inputs KK .....	96
Figure 46: Connection of the pressure sensor 4..20mA .....	97
Figure 47: Pressure switch terminal board .....	97
Figure 48: KIWA pressure boosting with pressure sensor .....	98
Figure 49: Kiwa configuration with pressure switches .....	98
Figure 50: System status in KIWA mode .....	99
Figure 51: Dip switches for KIWA pressure boosting .....	99
Figure 52: enabling P1 and P2 .....	99
Figure 53: Regulating the rated current SP and DP .....	100
Figure 54: Regulation with expansion vessel < 100 litres .....	101
Figure 55: Regulation with expansion vessel > 100 litres .....	101
Figure 56: Label and keys .....	102
Figure 57: Label, keys and display .....	103
Figure 58: Selection of the drop-down menus .....	105
Figure 59: Errors in the memory .....	106

**KEY**

The following symbols have been used in the discussion:



**Situation of general danger.** Failure to respect the instructions that follow may cause harm to persons and property.



**Situation of electric shock hazard.** Failure to respect the instructions that follow may cause a situation of grave risk for personal safety.

**WARNINGS**



**Read this documentation carefully before installation.**

Installation and operation must comply with the local safety regulations in force in the country in which the product is installed. Everything must be done in a workmanlike manner.

Failure to respect the safety regulations not only causes risk to personal safety and damage to the equipment, but invalidates every right to assistance under guarantee.



**Skilled personnel**

It is advisable that installation be carried out by competent, skilled personnel in possession of the technical qualifications required by the specific legislation in force.

The term skilled personnel means persons whose training, experience and instruction, as well as their knowledge of the respective standards and requirements for accident prevention and working conditions, have been approved by the person in charge of plant safety, authorizing them to perform all the necessary activities, during which they are able to recognize and avoid all dangers. (IEC 60730).



**Safety**

Use is allowed only if the electric system is in possession of safety precautions in accordance with the regulations in force in the country where the product is installed. Check that the panel has not been damaged.



In particular, check that all the internal parts of the panel (components, leads, etc.) are completely free from traces of humidity, oxide or dirt: if necessary, clean accurately and check the efficiency of all the components in the panel. If necessary, replace any parts that are not perfectly efficient.



It is indispensable to check that all the panel leads are correctly tightened in the respective clamps.



In the event of a long period of inactivity (or when any component has been replaced), it is advisable to perform on the panel all the checks indicated by standard EN 60730-1.

Failure to observe the warnings may create situations of risk for persons or property and will void the product guarantee.



**NOTA: Some functions might not be available, depending on the software version.**

**For software updates performed with DConnect Box see the respective manual.**

**RESPONSIBILITY**

**The Manufacturer does not vouch for correct operation of the electropumps or answer for any damage that they may cause if they have been tampered with, modified and/or run outside the recommended work range or in contrast with other indications given in this manual.**

The Manufacturer declines all responsibility for possible errors in this instructions manual, if due to misprints or errors in copying. The Manufacturer reserves the right to make any modifications to products that it may consider necessary or useful, without affecting their essential characteristics.

**1 GENERAL**

This documentation supplies the general indications for the storage, installation and use of the E.box electric panel, which has been designed and made for the control and protection of Sets of 1 or 2 pumps for: drainage (emptying), filling and pressure boosting.



**WHERE TO INSTALL THE PANEL:**

It is good practice to install the panel correctly, taking particular care to comply with the following indications.

- the panel must be kept in a completely dry place, far from sources of heat;
- the electric panel must be perfectly closed and isolated from the outside environment, so as to avoid the entry of insects, humidity and dust which could damage the electrical components, jeopardising their regular operation.
- Choose the sensors with a grade of protection suitable for the place in which they will be positioned.

**1.1 Technical characteristics**

	<b>E.box Plus E.box Plus D</b>	<b>E.box Basic E.box Basic D</b>
Power supply +10% - 15%	3 x 400V 3 x 230 V 1 x 230V	1 x 230V
Frequency	50/60Hz	50/60Hz
Grade of protection	IP 55	IP55
No. pumps that can be connected:	1 or 2	1 or 2
Maximum rated current of the pumps	12A	12A
Maximum rated power of the pumps	5.5kW at 3 x 400V 3.2kW at 3 x 230V 2.2kW at 1x230V	2.2kW at 1 x 230V
Environment temperature	-10 ÷ 40°C	10 ÷ 40°C
Storage temperature	-25°C ÷ 55°C	-25°C ÷ 55°C
Air relative humidity	50% at 40°C 90% at 20°C	50% at 40°C 90% at 20°C
Max. altitude:	1000 m (a.s.l.)	1000 m (a.s.l.)

Table 1: Technical data

**1.2 Protections**

The panel is self-protected and protects the electropumps against:

- **overloads and excess temperature with automatic reset,**
- **short circuits with fuses (only Plus model),**
- **excess currents in pumps (overload protection),**
- **abnormal voltages,**
- **lack of phase and thermal protection KK,**
- **dry operation,**
- **rapid starts,**
- **faults of the pressure sensor,**
- **inconsistency of floats and/or probes,**
- **blocking of the pumps.**

**2 INSTALLATION**



**Strictly respect the electric supply values indicated on the electrical data plate.**

- Although it has a grade of protection IP55, it is not advisable to use it in an atmosphere charged with oxidising or corrosive gases.
- The panels must be protected against the direct rays of the sun and against unfavourable weather conditions.
- Use good quality cables with a section suitable for the current required by their motors and for their length. Pay particular attention to the power cable which must carry the current for all the pipes connected.
- The sensors must be suitable for the place in which they are positioned.
- It is necessary to take suitable steps to keep the temperature inside the panel within the “limits of environment temperature use” listed below.
- High temperatures can lead to accelerated ageing of all the components, resulting in more or less severe malfunctions.
- It is also recommended that the person carrying out installation should ensure the cable clamps are watertight.
- Accurately tighten the cable clamps where the power cable enters the panel and those of any external controls, connected by the installer, so as to ensure that the cables cannot work loose from the clamps.

## 2.1 Electrical connections

Ensure that the main switch on the power distribution panel is in OFF position (0) and that no one can switch on the power accidentally before connecting the power cables to the terminals:



L1 - L2 - L3 -  for three-phase systems

L - N -  for single-phase systems

and to the isolating switch QS1.

Scrupulously observe all the regulations in force concerning safety and accident prevention.

Ensure that all the terminals are fully tightened, **paying particular attention to the earth screw.**



- Connect the cables to the terminal board as indicated in the wiring diagrams.
- Check that all the connecting cables are in excellent condition, with the external sheathing unbroken.
- **The system must be correctly and safely earthed as required by the regulations in force.**
- **Check that the differential switch that protects the system is of the correct dimensions.**

### 2.1.1 Instrumental checks to be carried out by the installer

- Continuity of the protection leads and of the main and supplementary equipotential circuits.
- Insulating resistance of the electric system between the active circuits L1-L2-L3 (short-circuited with each other) and the equipotential protection circuit.
- Testing the efficiency of the differential protection.
- Testing the voltage applied between the active circuits L1-L2-L3 (short-circuited with each other) and the equipotential protection circuit.
- Testing operation.

2.1.2 Boards and connections

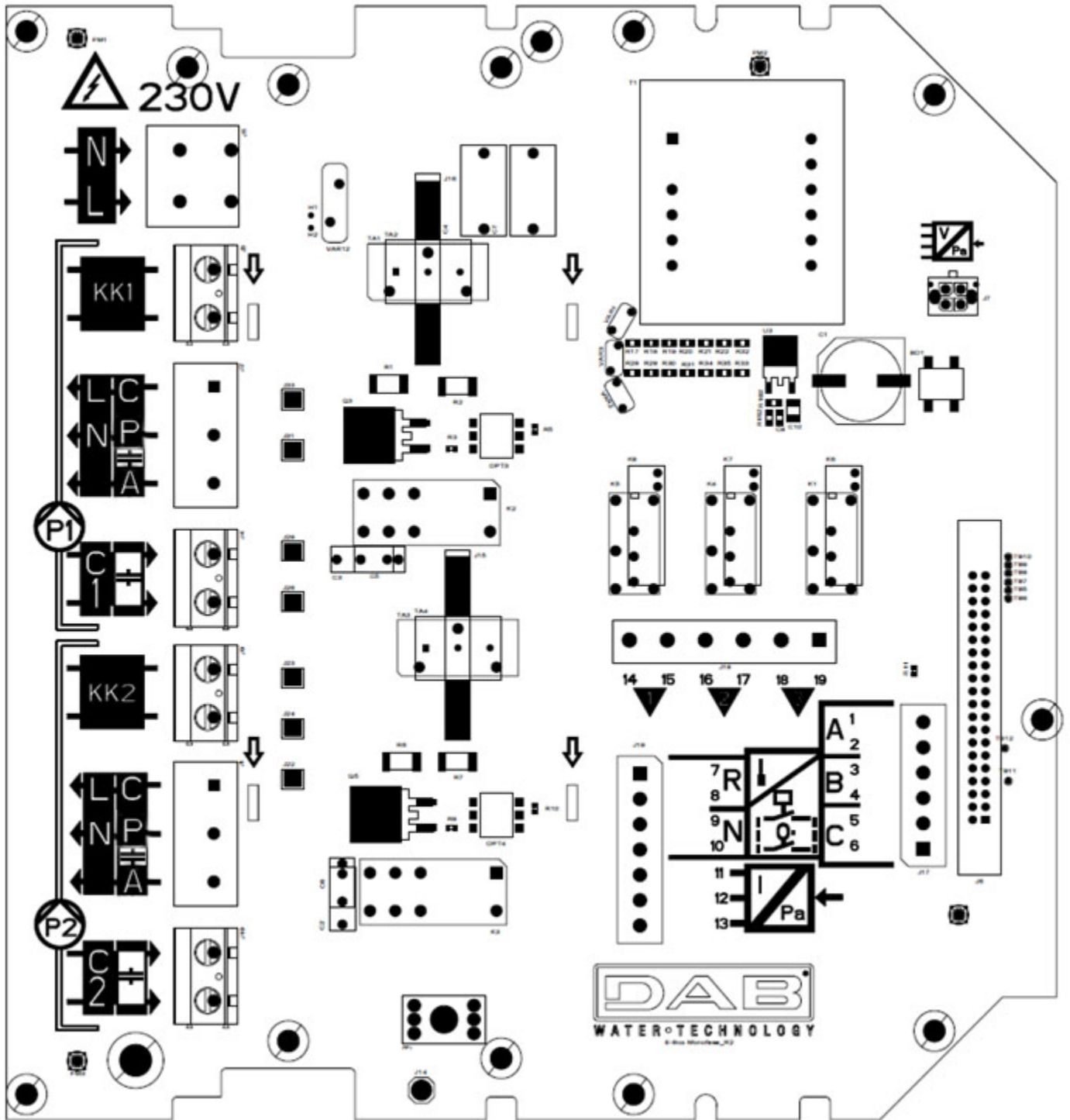

Figure 1: E.box Basic Board

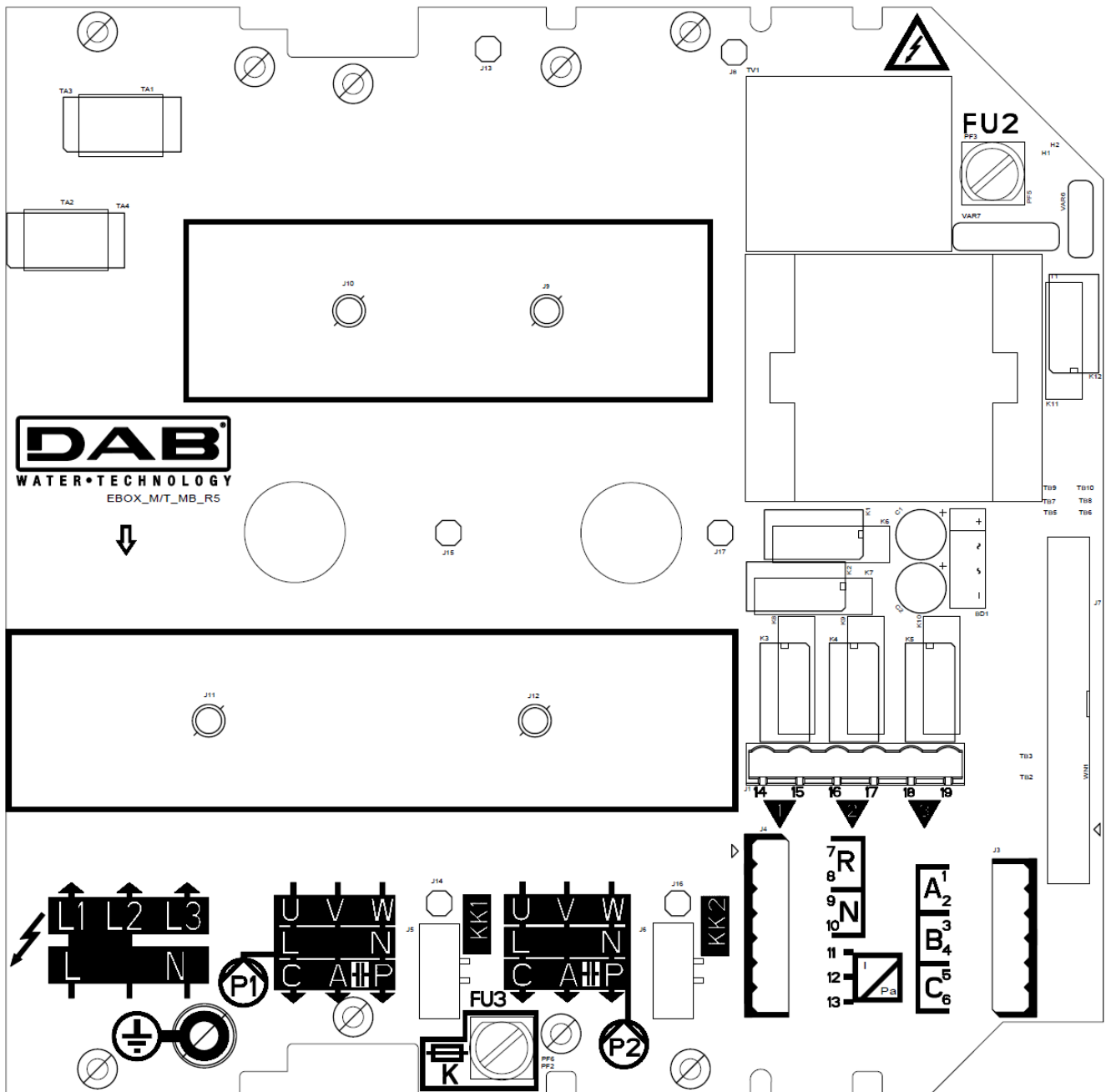

Figure 2: E.Box Plus Board

	Function
QS1	Supply line isolating switch (On the front panel of the e.box not shown in the figure)
L1 – L2 – L3	Three-phase power supply line connection
L – N	Single-phase power supply line connection
⊕	Earthing connection
U - V - W	Three-phase electrical connection of the pumps P1 and P2
L - N	Single-phase electrical connection of the pumps P1 and P2
C - A - P	Electrical connection for single-phase pumps P1 and P2 with external capacitor
C1 – C2	Electrical connection for external starting capacitor for single-phase pumps with external capacitor. For P1 and P2. Basic version only.
A - P	Electrical connection for external starting capacitor for single-phase pumps with external capacitor. For P1 and P2. Plus version only.
KK1- KK2	Thermal protection input for the motor of pumps P1 and P2
A-B-C	Terminals connecting digital inputs for level or pressure control

R-N	Terminals connecting digital alarm inputs
I: 11-12	Sensor input connection terminal
Q1: 14-15 Q2: 16-17 Q3: 18-19	Terminals connecting the alarms Q1, Q2, Q3.
FU2 - FU3	Panel protection fuses (Plus version only)
FU5	Pump P2 protection fuse (Plus version only)
FU4	Pump P1 protection fuse (Plus version only)



- The supply voltage of the E.BOX PLUS panel must be the same as that of the pumps used. For example, if the panel is fed with a supply voltage of 3~400V the pumps must be at 3~400V.
- The E.BOX BASIC panel must be fed with a supply voltage of 1~230V. The pumps must be single-phase 230V.
- Connect the earth cables of the pumps to the earth terminals in the E.Box panel! Make sure that all the cables have adequate dimensions for the currents they have to bear.
- If the single-phase pump needs an external capacitor, it can be placed inside the panel.
- If 2 pumps are used, they must be identical.
- Attention, an incorrect electrical connection could damage the E.Box panel.

## 2.2 Electrical connection of the pumps

### Connection of three-phase pumps



E.Box Basic



E.Box Plus

Figure 3: Electrical connection of pumps



Three-phase pumps can be connected only to the E.box Plus. They must be connected to the terminals P1 and P2 as shown in Figure 3. The correct sequence of phases U, V and W must be respected so that they turn in the correct direction.

#### Connection of single-phase pumps with internal capacitor.

The pumps must be connected to the terminals P1 and P2 shown in Figure 3. The neutral wire must be connected to the terminal N, the phase wire must be connected to the terminal with a screenprinted L.

#### Connection of single-phase pumps with external capacitor.

Pumps with an external capacitor must be connected to the terminals P1 and P2 shown in Figure 5. Particular care must be taken to respect the correspondence between the screenprinting and the names of the pump wires. The pump cable marked C must be connected to terminal C. The same applies to cables A and P. See Figure 3.

The pump capacitor can be placed inside the E.box panel, on the metal bracket provided.

The capacitors must be connected as shown in Figure 4. Take care because in the E.Box Plus they share the same terminal as the pump.

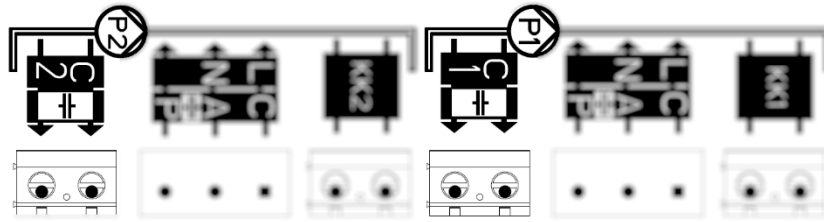

E.Box Basic

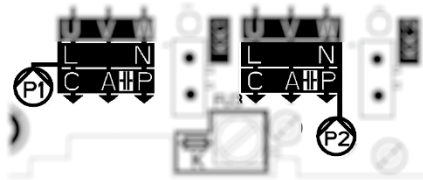

E.Box Plus

Figure 4: Connection of pump external capacitors

### 2.3 Power supply electrical connection



Before starting work, disconnect the power from the supply line. Use cables with a suitable size for the currents involved, considering that the in-line current is the total of the currents on the pumps.

In the case of single-phase power supply use terminals L and N. In the case of three phase power supply use terminals L1, L2, L3. See Figure 5 Electrical connection to the supply line.

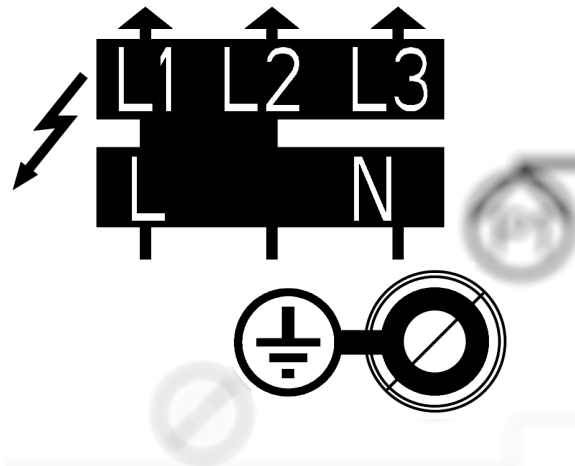

Figure 5: Electrical connection to the supply line



Connect the earth cables of the pumps to the earth terminals in the E.Box panel!

3 FRONT PANEL



Figure 6: Display label, present only on plus models



Figure 7: Front label

**Section concerning the panel**



White led indicating that the panel is fed

Red alarm led of the panel with the alarm reset button next to it. The number of blinks of the led indicates the type of error, as shown in the table below.

List of panel alarms. The number of blinks of the led indicates the type of alarm. On the display there is a complete indication of the problem. For further information, see the chapter PANEL PROTECTIONS AND ALARMS.

**Section concerning the pump**

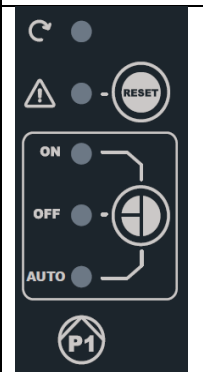

Green led, if lit it indicates that the pump is running.

Red alarm led of the pump with the alarm reset button next to it. The number of blinks of the led indicates the type of error, as shown in the table on the label. On the display there is a complete indication of the problem. For further information, see the chapter PANEL PROTECTIONS AND ALARMS.

Leds indicating the type of pump operation: ON always on, OFF always off, AUTO the pump is controlled by the panel.

Button for changing the pump operating mode. If held down for more than 3 seconds, it switches on the pump until the button is released. Simply pressing the button alternates the pump status from OFF to AUTO.

Pump to which the indications refer.

**4 PANEL INTERNAL REGULATING BOARD**

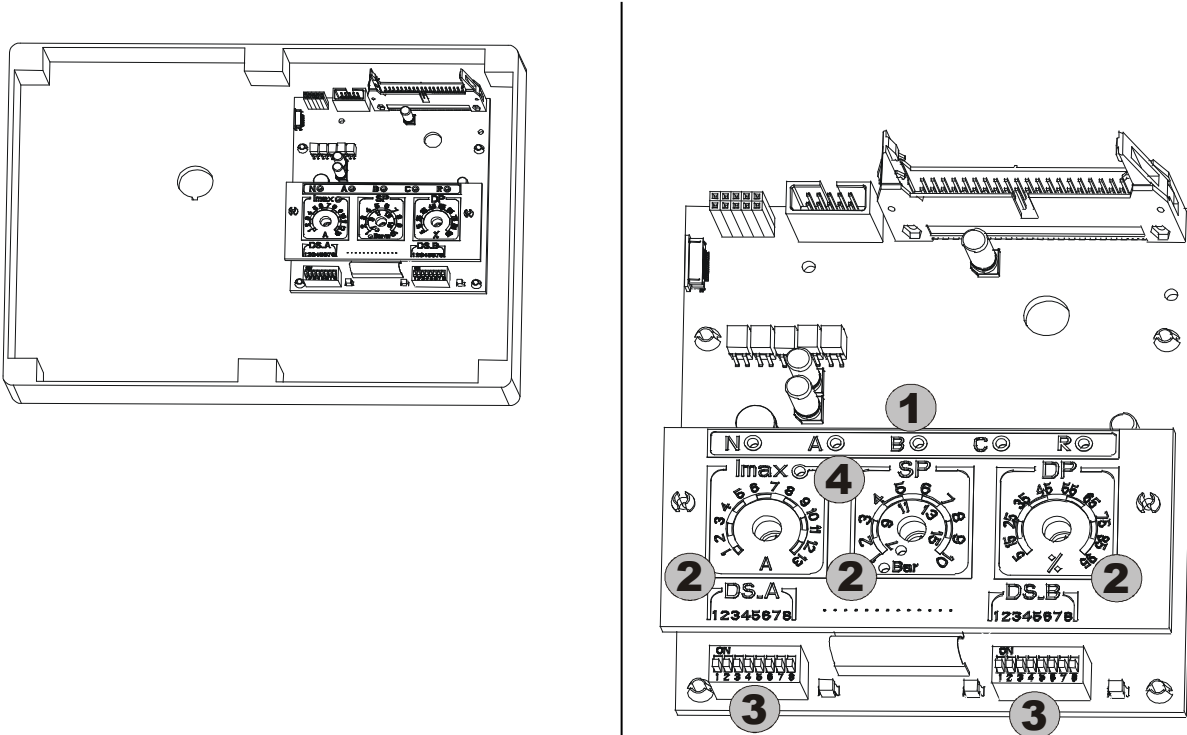

**Before starting regulation, switch off the mains power.**

To access the internal panel, slacken the screws, turn the cover of the electric panel downwards and operate the commands.

Ref.	Function
1	Warning lights for activating the digital inputs (N-A-B-C-R)
2	Trimmer for regulating the system (Imax – SP – DP).
3	Dip-switch for selecting functions (DS_A – DS_B).
4	Led indicating current overload set at the motor data plate values. For a correct setting the Led must be off.

**4.1 Trimmer for regulating the system (Imax – SP – DP)**

**T1 – Trimmer (Imax)**

Trimmer for setting the maximum current for the two electropumps P1 and P2 (0.25A – 13A).  
Set the Trimmer at the motor data plate value (the yellow led must be off).

**T2 – Trimmer (SP – system Set Point) / Trimmer 3 (DP – Pressure level differential)**

Trimmer for setting the pressures or level of the system.

- The trimmer SP (set by DS\_B5) presents a double regulating scale in bar: from 1 to 10 bar or from 7 to 15 bar corresponding to the led lit, if a pressure sensor is used in the booster sets. This scale can also be expressed in metres (as an optional version, using the plate provided): **from 1 to 3 metres or from 2 to 5 metres** corresponding to the led lit, if an analog level sensor is used in the filling and draining sets.

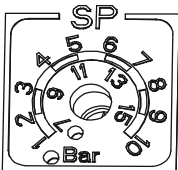

Standard regulation in bars

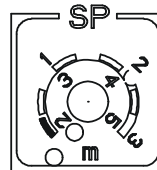

Optional regulation in metres (plate supplied)

- The DP regulation is expressed as a percentage with respect to the value set in SP.



4.2 Dip-switch for selecting functions (DS\_A – DS\_B)

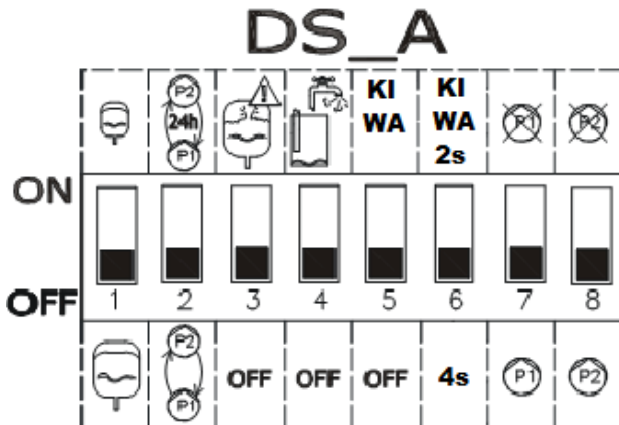

1.	N o .	ON	OFF
1		STANDARD expansion vessels, minimum 19 litres per pump. Effective only in pressure boosting and kiwa	MAXI expansion vessels, over 100 litres per pump. Effective only in pressure boosting and kiwa
2		Automatic exchange between pump P1 and P2 every 24 hours.	Automatic exchange between pump P1 and P2 at each start.
3		Checks too frequent starts and reduces them to 8 per minute per pump.	Allows all the starts requested by the system.
4		Dry operation protection active. Pressure boosting only. Indicates dry operation if the pressure falls below 0.5bar.	Dry operation protection not active.
5		Activates KIWA operating mode if pressure boosting is active.	Does not activate KIWA mode.
6		KIWA mode switch-off delay of 2 seconds.	KIWA mode switch-off delay of 4 seconds.
7 (**)		Pump P1 not available.	Pump P1 available.
8 (**)		Pump P2 not available.	Pump P2 available.

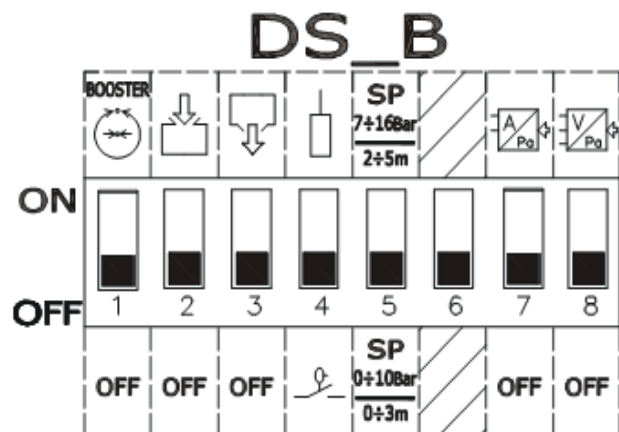

2.	N o.	ON status	OFF status
1 (*)		Operation as pressure boosting set.	OFF
2 (*)		Operation as filling set.	OFF
3 (*)		Operation as draining set.	OFF
4		Use of electric probes.	Use of floats.
5		Pressure set point scale: 7-16 bar / 2-5 m.	Pressure set point scale: 1-10 bar / 0-3 m.
6		Not used	Not used
7 (**)		Regulation with analog sensor with current output.	OFF
8 (**)		Regulation with analog sensor with voltage output.	OFF

(\*) Only one (and at least one) of these Dip Switches can be in ON position.

(\*\*) Only one (or none) of these Dip Switches can be in ON position.

5 PRESSURE BOOSTING FUNCTION

The E.box panel can be used for making a system to increase water pressure. As control inputs, either pressure switches on a pressure sensor can be used. To operate, the panel requires an expansion vessel.

5.1 Expansion vessel

In pressure boosting it is necessary to use an expansion vessel of at least 19 litres per pump.

5.2 Electrical connections of pump and supply

Connect the supply line and the pumps as described in the chapter ELECTRICAL CONNECTIONS.

### 5.3 Connection of additional protections: high pressure, low pressure and motor thermal protection

It is possible, but not necessary, to use the alarm inputs to the E.box so that the pumps stop in the case of pressure that is too high, too low, or too high motor temperature. In the case of an alarm, the pumps stop, the alarm leds blink, the corresponding alarm outputs are activated. If the display is present, the type of alarm is indicated. When the alarm conditions no longer exist, the E.box resumes normal operation.

- **Alarm, Pressure in system too high:** the pressure switch must be installed in the delivery of the set. The normally closed contact of the pressure switch must be connected to terminal R of the E.box. The pressure switch must be set at the maximum pressure that can be reached by the system. If it is not used, the contact is jumpered.
- **Alarm, Pressure in system too low:** the pressure switch can be installed either on suction or on delivery depending on the type of system. The pressure switch must be connected to terminal N of the E.box, it must be set at the minimum pressure necessary for the system to work correctly. The contact must open if the pressure falls below the minimum value. This contact may be used either to prevent blocks for lack of water or to discover burst pipes. A level probe or float can also be connected to this alarm to check the state of a tank or well. If it is not used, the contact is jumpered.

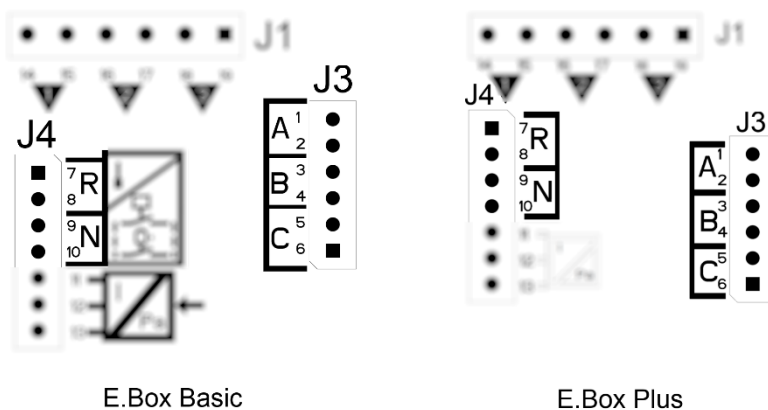

Figure 8: Inputs and outputs

- **Motor thermal protection:** the device has an input for the thermal protection of each motor. If the motor used is provided with thermal protection, this protection can be connected to the terminals KK shown in Figure 9. If there is no protection in the motor, the terminals must be jumpered.

If the alarms are not used, the corresponding inputs must be jumpered. So jumpers must be fitted on the inputs of the contacts N, R, KK1 and KK2. These jumpers are provided with the E-box.

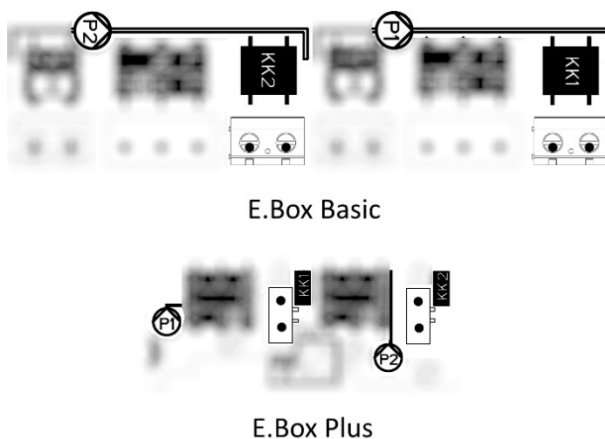

Figure 9: Thermal protection inputs KK

### 5.4 Connection of the alarm outputs



**If alarms occur, this is indicated by the E.box in three ways:**

- With the leds on the front panel, which give a number of blinks depending on the error.
  - With the outputs Q1, Q2, Q3 which short circuit as specified in Table 17. The operating logic of the alarms is as follows: Q1 closes following malfunctions of pump 1, Q2 of pump 2 and Q3 for general errors.
  - With the indications on the display (if present). In this case it is also possible to see the alarm log.
- If the panel is not fed, Q1, Q2 and Q3 are closed, so they give an alarm signal.

**5.5 Operation with pressure sensor (recommended choice)**

It is recommended to use this operating mode, rather than pressure switches, because it allows greater flexibility in managing the system, the pressure distributed by the set can be seen, and installation is easier. In this case it will be possible to set the Set Point pressure and the pressure differential for the restarting and stopping of the pumps.

**5.6 Connection of the pressure sensor**

The pressure sensor must be connected to the terminal board, see Figure 10 Pressure sensor connection, according to the following diagram:

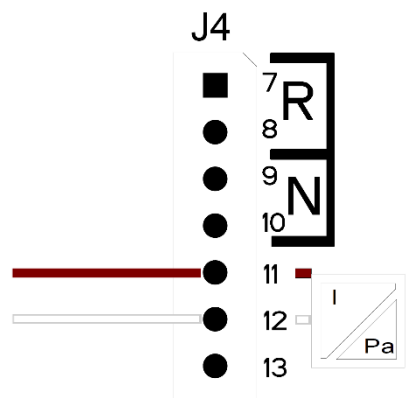

Pressure sensor connections 4..20mA	
Terminal	Cable to be connected
11	+VCC (brown)
12	- OUT/GND (white)

Figure 10: Pressure sensor connection 4..20mA



**ATTENTION:** incorrect wiring of the sensor can damage the appliance and the sensor.

**NOTE:** the choice of sensor limits the maximum set-point that can be reached.

**5.7 Operation with pressure switches**

If you decide to operate the booster set with pressure switches, they must be connected on the delivery of the booster set. The pressure switches to be used are B and C and they are connected as indicated in the next chapter.

**Connection of pressure switches**

The pressure switches must be connected to the contacts B and C of the terminal board shown in Figure 11.

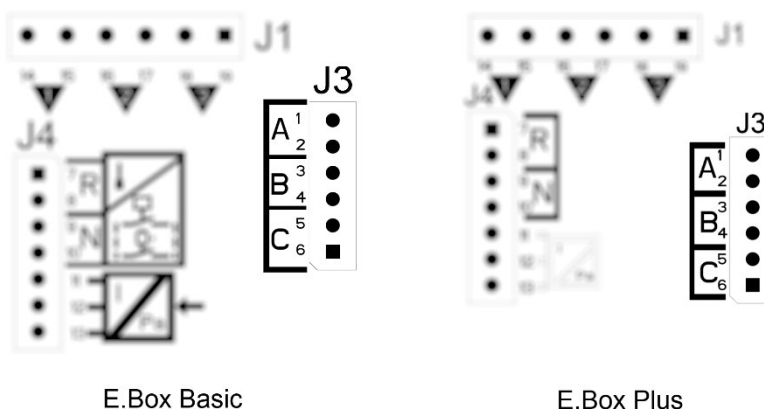

Figure 11: Terminals for connecting the pressure switches

**5.8 Setting with the display, wizard**

The E.box D can be configured with a simple wizard. The device asks the user for all the parameters necessary for its configuration. If necessary, it can be loaded by pressing the “set” + “+” keys when switching on. To navigate in the wizard, use the following keys:

- “mode” to accept the parameter displayed and move on to the next
- “mode” held down for more than 1 second to return to choose the parameter
- “-” and “+” to vary the value of the parameter.

5.9 Setting with a pressure sensor



Figure 12: Configuration with a pressure sensor

5.10 Configuration with pressure switches



Figure 13: Configuration with pressure switches

5.11 Setting the E.box with dip switches

If the E.box is provided with a display, it is recommended to use the display for configuration. Otherwise it is possible to use the dip switches inside the panel and set them as shown in Figure 14 Dip switches for pressure boosting.

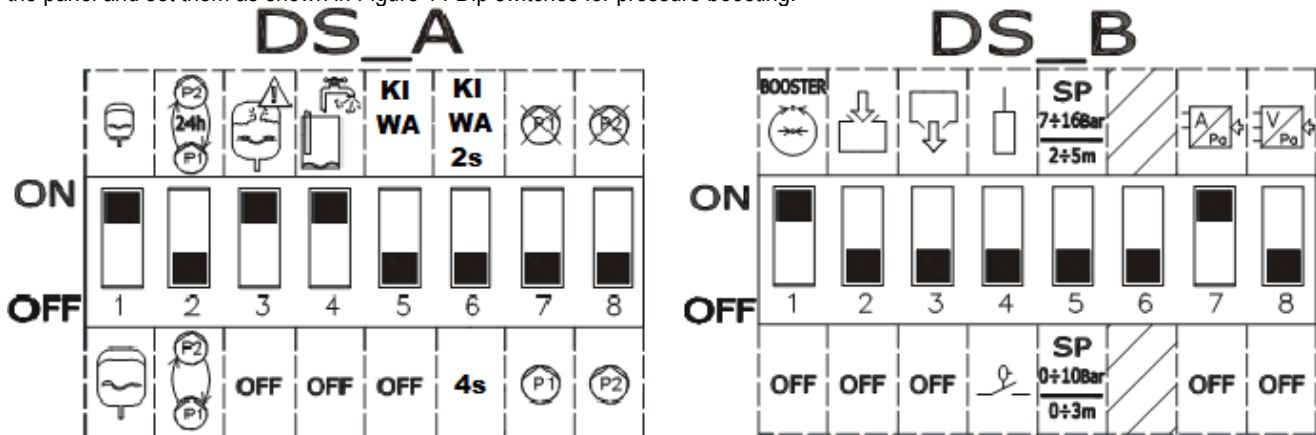



Figure 14: Dip switches for pressure boosting

The following modifications may be made during configuration:

- If the expansion vessel is larger than 100 litres, set **DS\_A1** at **OFF**.
- If you want the pumps to be exchanged every 24 hours and not at each restart, set **DS\_A2** at **ON**.
- If you do not want protection against too rapid restarts, set **DS\_A3** at **OFF**.
- If you do not want protection against lack of water, set **DS\_A4** at **OFF**.
- If you do not want to use the pump P1 set **DS\_A7** at **ON**.
- If you do not want to use the pump P2 set **DS\_A8** at **ON**.
- If you intend to use a set-point between 7 and 16 bar, set **DS\_B5** at **ON**.
- If you intend to use pressure switches, set **DS\_B7** at **OFF**.

5.12 Activation of the set



To activate the set it is necessary to enable the pumps. During the first configuration, for safety's sake, the pumps are disabled and are OFF. To change to automatic mode, just briefly press the  buttons on the pumps P1 and P2. As shown in Figure 15 Enabling P1 and P2.

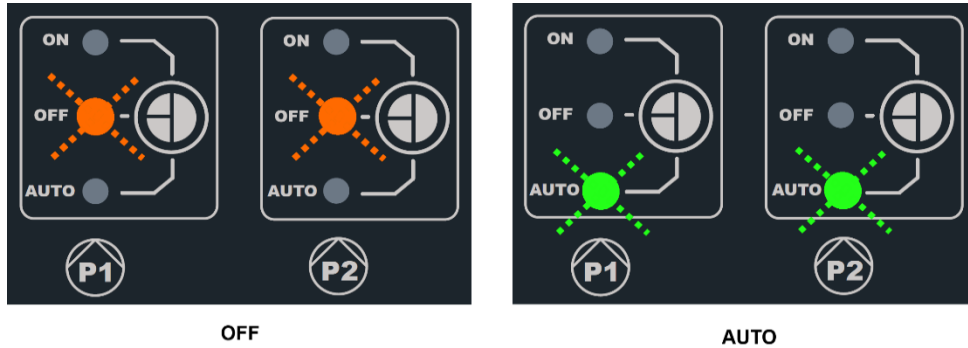

Figure 15: Enabling P1 and P2.

5.13 Regulating the rated current of the pumps (Imax), Set point (SP) and differential restarting pressure (DP)

With a straight tip screwdriver, position the indices in the centre of the graduated scales, shown in Figure 16 Regulating: Imax, SP and DP, so that:

- Imax indicates the rated current of the installed pumps, which you can find on the pump data plate.
- SP indicates the desired set point pressure.
- DP is the pressure variation, in percentage of the set point, necessary to restart the pumps.



Attention, the differential restarting pressure is calculated as  $SP * DP$ . If the set point is 4 bar and DP is 50%, the pressure differential RP is 2 bar.

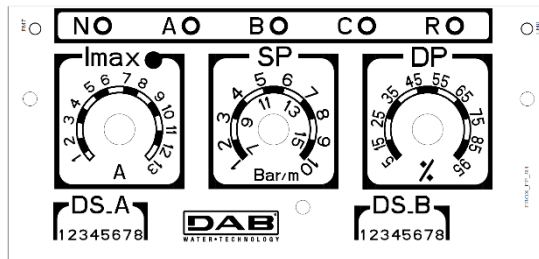

Figure 16: Regulating: Imax, SP and DP

5.14 System operation

Pressure switches:

The operating logic is the following:

Pressure boosting operation with pressure switches		
	Start	Stop
P1	Pressure switch B = CLOSED	Pressure switch B = OPEN
P2	Pressure switch C = CLOSED	Pressure switch C = OPEN

Table 2: Pressure boosting operation with pressure switches

- Pressure switch connected to input B starts and stops Pump 1
- Pressure switch connected to input C starts and stops Pump 2

**Pressure sensor:**

RP is the pressure differential, and indicates the pressure variation around the Set Point for which the pumps are switched on. In systems with a display it is set directly. In systems without a display, DP is set as a percentage of the Set Point.  $RP = SP \cdot DP$ . For further information see Figure 17 and Figure 18.

The operating logic is the following:

Pressure boosting operation standard vessel < 100 litres		
Pumps	Start	Stop
P1	System pressure $\leq$ SP	System pressure $\Rightarrow$ SP+RP
P2	System pressure $\leq$ SP – RP/2	System pressure $\Rightarrow$ SP+RP

Table 3: Pressure boosting operation standard vessel < 100 litres

Operation with additional expansion vessel > 100 litres		
Pumps	Start	Stop
P1	System pressure $\leq$ SP	System pressure $\Rightarrow$ SP+RP
P2	System pressure $\leq$ SP – 2%	System pressure $\Rightarrow$ SP+RP

Table 4: Operation with additional expansion vessel > 100 litres

- The first pump starts when the pressure falls below the Set Point and it stops when it reaches the Set Point pressure + differential restarting pressure.
- The second pump starts when the pressure falls below the Set Point minus half the differential restarting pressure, or 2% of the Set Point if vessels over 100 litres are used. It stops when the pressure in the system reaches the Set Point pressure + differential restarting pressure.



Attention: If DIP SWITCH configuration is used, the differential restarting pressure is calculated as  $SP \cdot DP$ . If the set point is 4 bar and DP is 50%, the restarting pressure RP is 2 bar.

The indications pump P1 and P2 are only indicative. If exchange mode is activated, the pumps P1 and P2 are alternated as specified in the exchange mode.

The two pumps will always be started alternately with a minimum interval of 2 seconds from each other.

Example of Regulation with Standard expansion vessel and Regulation with additional expansion vessel:

SP= 4 bar

RP= 2 bar Attention: if DP is set (with the trimmers)  $RP=SP \cdot DP$



Figura 17: Regulation with expansion vessel < 100 litres



Figura 18: Regulation with expansion vessel > 100 litres

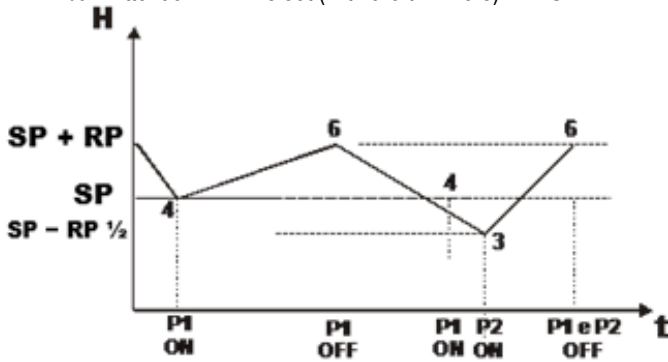

## 6 FILLING FUNCTION

The E.box panel can be used for making filling systems. As control inputs, any of the following may be used: floats, level probes or a depth sensor.

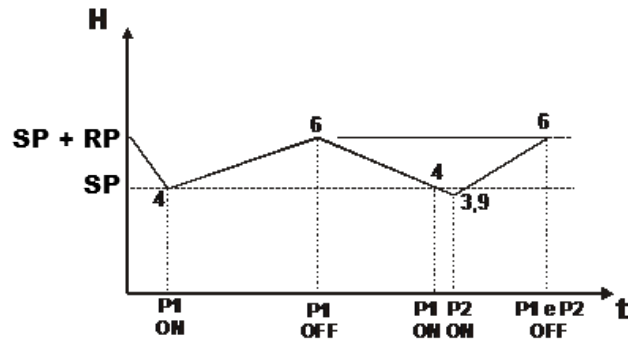
The general diagram is as follows:

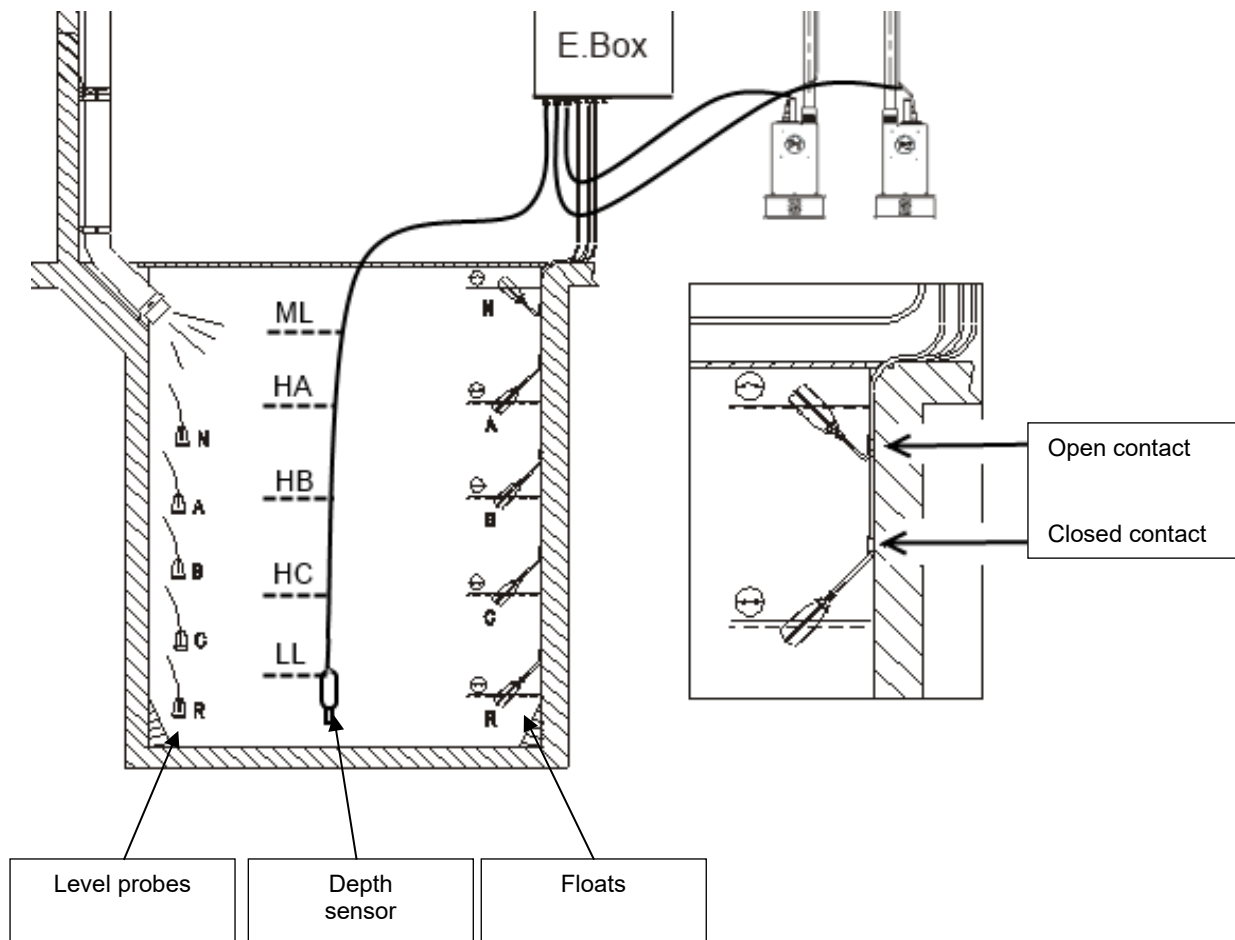

Figure 19: Diagram of filling system inputs

### 6.1 Electrical connections of pump and supply

Connect the supply line and the pumps as described in chapter 2.1.

### 6.2 Control inputs

As inputs the E.box accepts either floats, level probes or depth sensors. Particular care must be taken:

- Use floats for filling, closed contact with low water level, see Figure 19 Diagram of filling system inputs.
- Floats and level probes cannot be used at the same time.
- Level probes can only be used with clear, clean water.
- The maximum level and minimum level alarms can be generated by floats or by level probes, or, if the depth sensor is used, by thresholds of the value read by the sensor itself.

### 6.3 Connection of additional protections: overflow, water lack, motor thermal protection

It is possible, but not necessary, to use the alarm inputs to the E.box so that the pumps stop in the case of reaching the maximum level, or too high motor temperature. In the case of an alarm, the pumps stop, the alarm leds blink, the corresponding alarm outputs are activated.



**If the minimum level is reached, the pumps are activated. The alarm leds blink, the corresponding alarm outputs are activated.**

If the display is present, in all cases the type of alarm is indicated.

When the alarm conditions no longer exist, the E.box resumes normal operation.



- **Maximum level alarm:** the signal for this alarm may come from a float, from a level probe, or from the depth sensor (only for E.Box with display). The level probe or float must be connected to terminal N of the E.box and positioned in the tank in the highest point that the liquid can safely reach.



**Note:** if this alarm is not used, the terminal N must be jumpered except in the case where level probes are used.

If the depth sensor is used to obtain this alarm (only for E.Box with display), the threshold ML must be set at the highest level that the liquid can safely reach.

- **Minimum level alarm:** the signal for this alarm may come from a float, from a level probe, or from the depth sensor (only for E.Box with display). The level probe or float must be connected to terminal N of the E.box and positioned in the tank in the highest point that the liquid can safely reach. If the depth sensor is used to obtain this alarm, the threshold LL must be set at the lowest level that the liquid can safely reach.



**Note:** if this alarm is active, the pumps start automatically.

**Note:** if this alarm is not used, and the protection devices are level probes, the input R must be jumpered. Not in other cases.

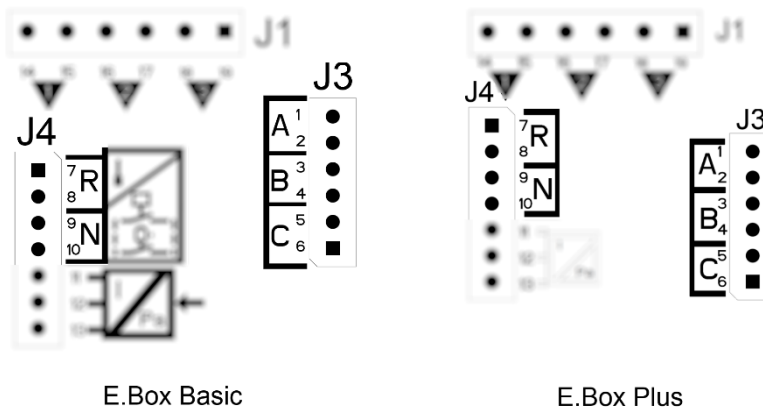

Figure 20: Inputs and protections

- **Motor thermal protection:** the device has an input for the thermal protection of each motor. If the motor used is provided with thermal protection, this protection can be connected to the terminals KK. If the protection is not present in the motor, the terminals must be jumpered. The terminals can be seen in Figure 21.

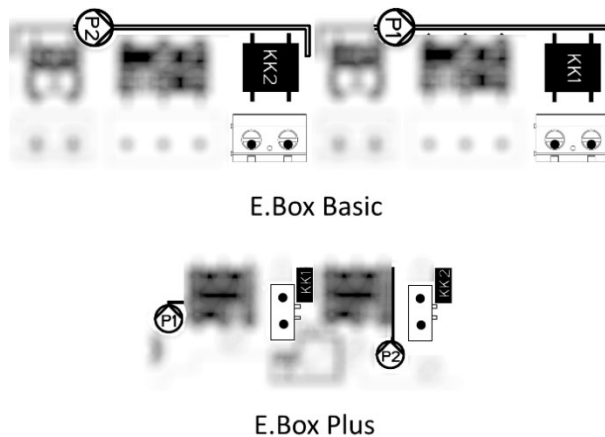

Figure 21: Thermal protection inputs KK

#### 6.4 Connection of the alarm outputs

If alarms occur, this is indicated by the E.box in three ways:

- With the leds on the front panel, which give a number of blinks depending on the error.
- With the outputs Q1, Q2, Q3 which short circuit as specified in Table 17. The operating logic of the alarms is as follows: Q1 closes following malfunctions of pump 1, Q2 of pump 2 and Q3 for general errors.
- With the indications on the display (if present). In this case it is also possible to see the alarm log.

If the panel is not fed, Q1, Q2 and Q3 are closed, so they give an alarm signal.

### 6.5 Connection of floats or level probes

2 or 3 control inputs can be used which must be connected as follows:

- **System with 2 floats:** in this case inputs B and C are used (A must not be used). The floats in the tank must be positioned as in Figure 19. For electrical installation, see Figure 22.
- **System with 2 level probes:** in this case inputs B and C are used (A must not be jumpered). The level probes in the tank must be positioned as in Figure 19. For electrical installation, see Figure 22.
- **System with 3 floats or level probes:** in this case inputs A, B and C are used. The floats or level probes must be positioned as in Figure 19. For electrical installation, see Figure 22.

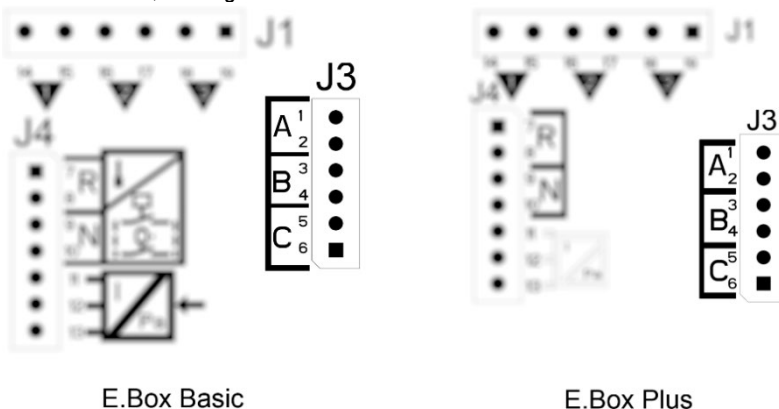

Figure 22: Inputs



**Common contact of the inputs A, B, C, R, N.** There is only one common contact for all the inputs and it is connected to the even terminals from 2 to 10. So, if electric probes are used, the common contact for the inputs: A, B, C, R, N must be connected to the terminals with even numbers: 2, 4, 6, 8, 10.

**Level probes:** they can be used only with clear, clean water.

### 6.6 Depth sensor connection

The E.Box may use a depth sensor as a control device. If an E.box with a display is used, the maximum or minimum level alarms can be generated with the information from the depth sensor. So it is not necessary to connect floats or level probes to the inputs R or N. If maximum reliability is desired, as well as the depth sensor 2 floats or level probes can also be used, for the alarms R and N.

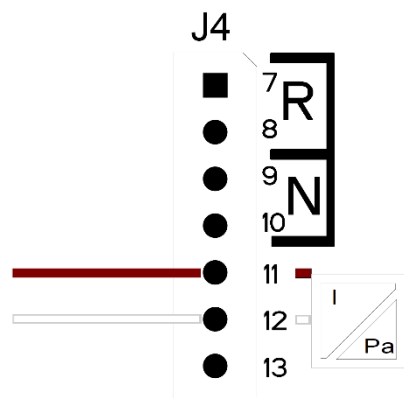

Depth sensor connections 4 – 20mA	
Terminal	Cable to be connected
11	+VCC
12	- OUT/GND

Figure 23: Depth sensor connection

The depth sensor must be positioned near the bottom of the tank, ensuring that it is above any solid residue, present or future.



**ATTENTION:** incorrect wiring of the sensor can damage the appliance and the sensor.

### 6.7 Setting with the display, wizard

The E.Box D can be configured with a simple wizard. The device asks the user for all the parameters necessary for its configuration. If necessary, it can be loaded by pressing the “set” + “+” keys when switching on. To navigate in the wizard, use the following keys:

- “mode” to accept the parameter displayed and move on to the next,
- “mode” held down for more than 1 second to return to choose the parameter,
- “-“ e “+” to vary the value of the parameter.

6.8 Configuration of floats or level probes



Figure 24: Configuration of Filling with floats or level probes

After configuration, the system status will be one of those shown depending on whether level probes or floats are used.

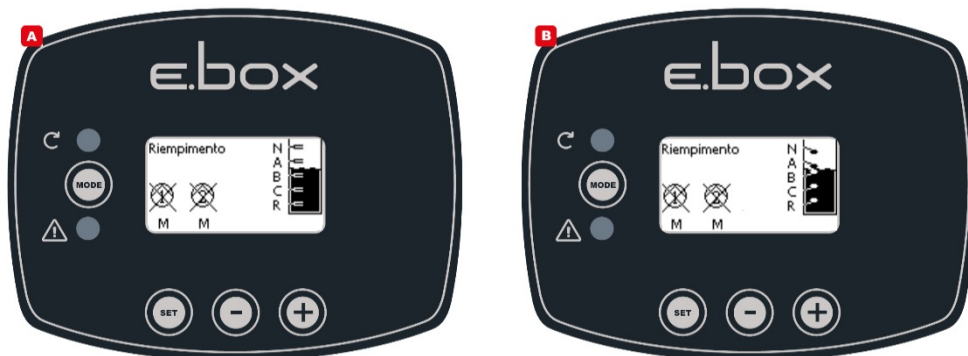

Figure 25: System status in filling mode, with floats or level probes as control inputs

6.9 Configuration with a depth sensor



Figure 26: A System status with depth sensor only, B depth sensor and floats, C depth sensor and level probes

### 6.10 Setting the E.box with dip switches

If the E.box is provided with a display, it is recommended to use the display for configuration. Otherwise it is possible to use the dip switches inside the panel and set them as shown in Figure 27.

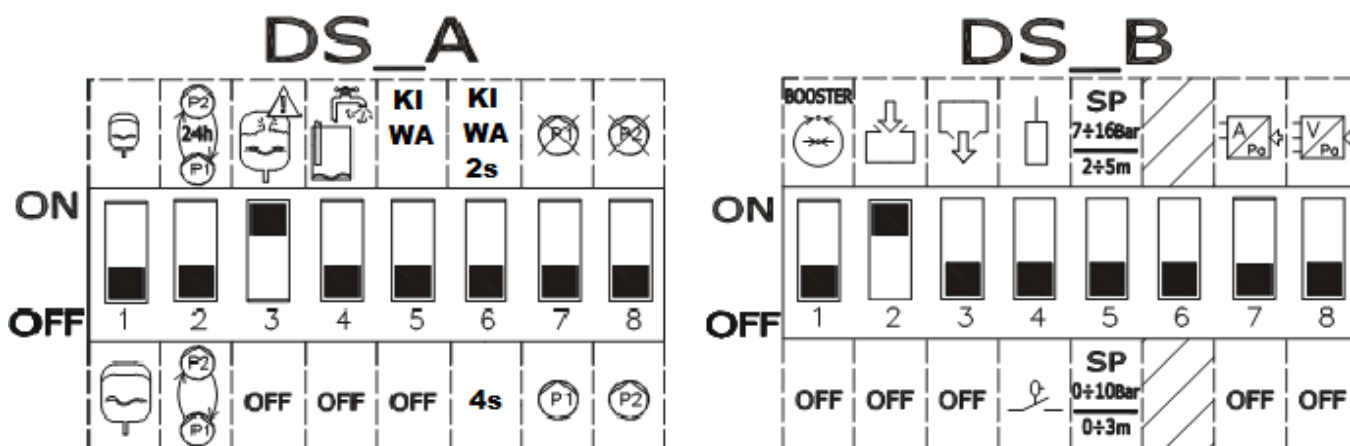

Figure 27: Setting the filling dip switches

The following modifications may be made during configuration:

- If you want the pumps to be exchanged every 24 hours and not at each restart, set **DS\_A2** at **ON**.
- If you do not want protection against too rapid restarts, set **DS\_A3** at **OFF**.
- If you do not want to use the pump P1 set **DS\_A7** at **ON**.
- If you do not want to use the pump P2 set **DS\_A8** at **ON**.
- If level probes are used and not floats, set **DS\_B4** at **OFF**
- If a depth sensor is used, set **DS\_B7** at **ON** and position **DS\_B5** according to the desired scale.

### 6.11 Activation of the set



To activate the set it is necessary to enable the pumps. During the first configuration, for safety's sake, the pumps are disabled and are OFF. To change to automatic mode, just briefly press the buttons on the pumps P1 and P2. As shown in Figure 28.

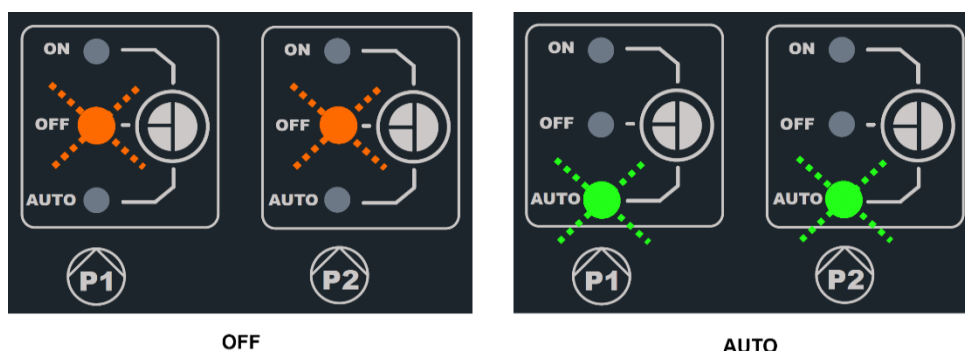

Figure 28: Enabling P1 and P2.

### 6.12 Regulating the rated current of the pumps (Imax) and the pump starting and stopping levels (only with depth sensor connected)

With a straight tip screwdriver, position the indices in the centre of the graduated scales, shown, so that:

- Imax indicates the rated current of the installed pumps, which you can find on the pump data plate.
- SP represents the maximum level in the tank (LMAX) that you want the water to reach during normal operation.
- DP represents the minimum level in the tank (LMIN) that you want the water to reach during normal operation. DP is expressed as a percentage of SP.



Attention, SP and DP have significance only if a depth sensor is used. For their meaning, refer to Figure 30. The scale changing label 0-3m/2-5m must be applied on SP.

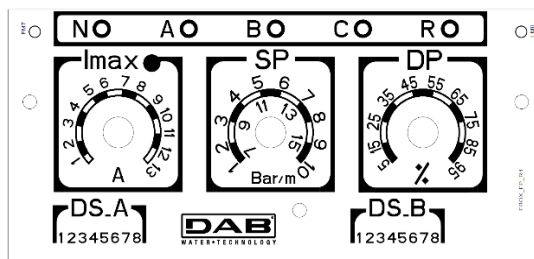

Figure 29: Regulating the rated current SP and DP

**6.13 System operation:**

**Operation with 2 floats or level probes**

The operating logic is the following:

- Float or level probe connected to input B starts pump P1 and stops both pumps.
- Float or level probe connected to input C starts pump 2.

Filling operation with 2 floats		
	Start	Stop
<b>Pump P1</b>	Float or level probe on B	Float or level probe on B
<b>Pump P2</b>	Float or level probe on C	Float or level probe on B

Table 5: Filling operation with 2 floats

**Operation with 3 floats or level probes**

The operating logic is the following:



- Float or level probe connected to input B starts pump P1.
- Float or level probe connected to input C starts pump P2.
- Both pumps are stopped on the float or level probe connected to A.

Filling operation with 3 floats		
	Start	Stop
<b>Pump P1</b>	Float or level probe on B	Float or level probe on A
<b>Pump P2</b>	Float or level probe on C	Float or level probe on A

Table 6: Filling operation with 3 floats



**Note: the function with 3 floats is used in installations with deep narrow tanks that do not allow an ample travel of the floats!**

**Operation with depth sensor and display**

If a depth sensor is being used, with an E.box with display, it will be possible to set independently the starting level of pump P1, of pump P2, and the stopping level of both. In particular:

- HA is the stopping level of the pumps P1 and P2.
- HB is the starting level of pump P1.
- HC is the starting level of pump P2.

It will also be possible to set the alarm level for maximum or minimum tank level. The minimum settable level (including the minimum alarm level) cannot be lower than 15 cm. The maximum settable level (including the maximum alarm level) cannot be higher than the tank height minus 5 cm. The various levels are separated from one another by a minimum of 5 cm.

**Operation with depth sensor without display**

In operation with a depth sensor, the parameters must be set with the Trimmers SP and DP:

- SP represents the maximum level in the tank ( $L_{MAX}$ ) that you want the water to reach during normal operation.
- DP represents the minimum level in the tank ( $L_{MIN}$ ) that you want the water to reach during normal operation. DP is expressed as a percentage of SP.

If the level in the tank is the same as or lower than DP, the pump P1 is started and, if the level continues to fall, pump P2 is also started after a delay of 4 seconds.

When level SP is reached, both pumps stop.

The following table sums up the behaviour described:

Operation with depth sensor, without display		
	STARTING	STOPPING
<b>P1</b>	Tank level $\leq$ DP	Tank level = SP
<b>P2</b>	Pump P1 = started for at least 4 seconds and tank $\leq$ DP	Tank level = SP

Table 7: Operation with depth sensor, without display

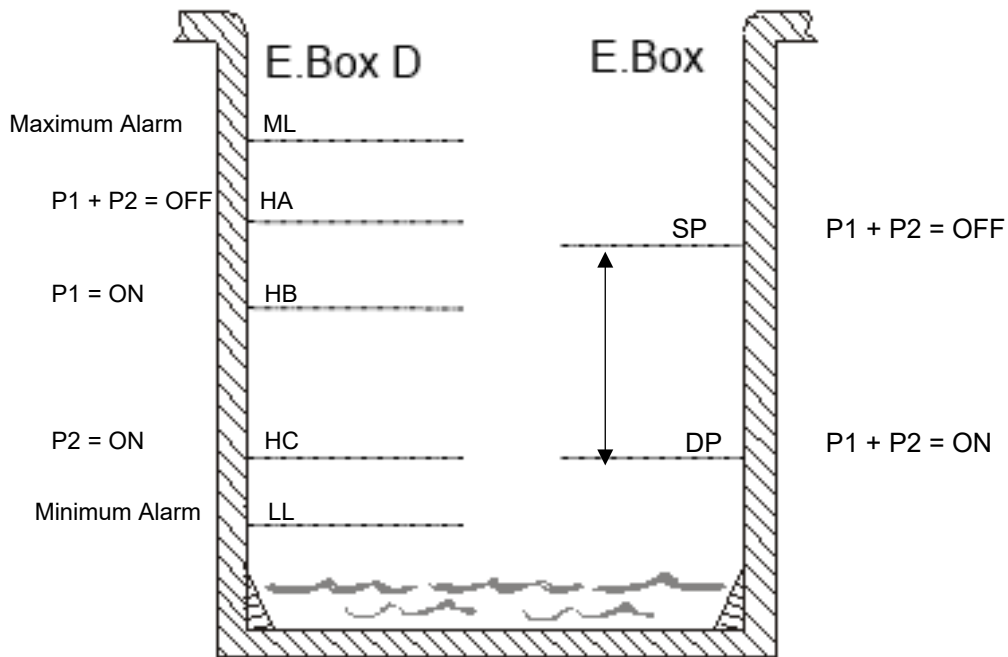

Figure 30: Filling with a depth sensor

E.box with display

E.box without display



## 7 DRAINING FUNCTION

The E.box panel can be used as a control and protection panel for draining systems. As control inputs, any of the following may be used: floats, level probes or a depth sensor.

The general diagram is as follows:

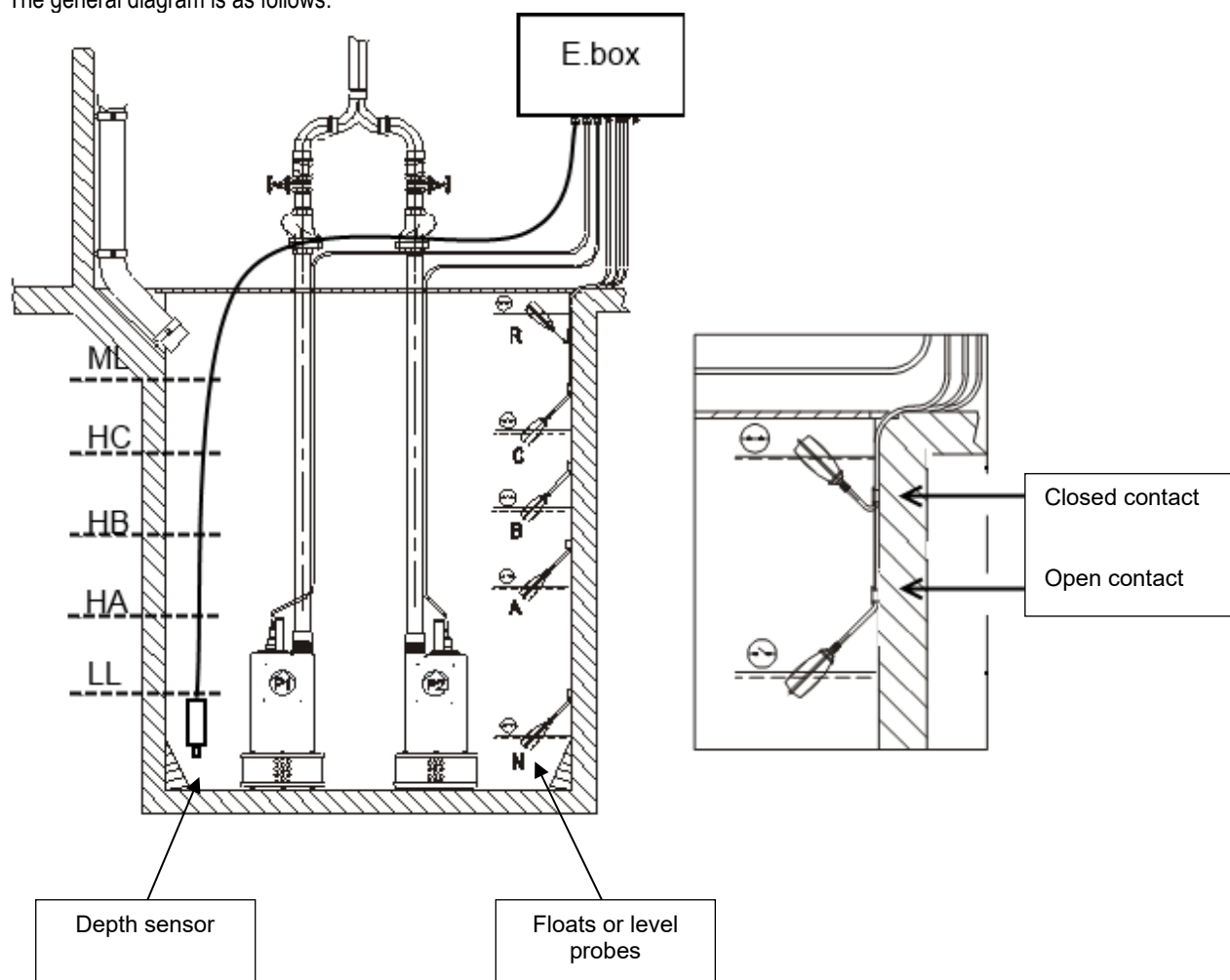

Figure 31: Draining system diagram

### 7.1 Electrical connections of pump and supply

Connect the supply line and the pumps as described in chapter 2.1.

### 7.2 Control inputs

As inputs the E.box accepts either floats, level probes or depth sensors. Particular care must be taken:

- Use floats for draining, closed contact with low water level, see Figure 31 draining.
- Floats and level probes cannot be used at the same time.
- Level probes can only be used with clear, clean water.
- If the depth sensor is being used, the maximum level and minimum level alarms can be generated by floats or by level probes, or by thresholds of the value read by the sensor itself.

### 7.3 Connection of additional protections: overflow, water lack, motor thermal protection

It is possible, but not necessary, to use the alarm inputs to the E.box so that the pumps stop in the case of reaching too low a level, or too high motor temperature. In the case of an alarm, the pumps stop, the alarm leds blink, the corresponding alarm outputs are activated.



**If too high a level is reached, the pumps are activated. The alarm leds blink, the corresponding alarm outputs are activated.**

If the display is present, in all cases the type of alarm is indicated.

When the alarm conditions no longer exist, the E.box resumes normal operation.



- **Maximum level alarm:** the signal for this alarm may come from a float, from a level probe, or from the depth sensor (only for E.Box with display). The level probe or float must be connected to terminal R of the E.box and positioned in the tank in the highest point that the liquid can safely reach.



**Note:** if this alarm is not used, the contacts of the terminal R are left open.

If the depth sensor is used to obtain this alarm, the parameter ML must be set at the highest level that the liquid can safely reach.



**Note:** if this alarm is active, the pumps start automatically.

- **Minimum level alarm:** the signal for this alarm may come from a float, from a level probe, or from the depth sensor (only for E.Box with display). The level probe or float must be connected to contact N of the E.box and positioned in the tank in the lowest point that the liquid can safely reach.

**Note:** in case of an alarm, the pumps stop.

If the depth sensor is used to obtain this alarm (only for E.Box with display), the parameter LL must be set at the lowest level that the liquid can safely reach.

**Note:** if this alarm is not used, input N must be jumpered. To identify input N, refer to Figure 32.

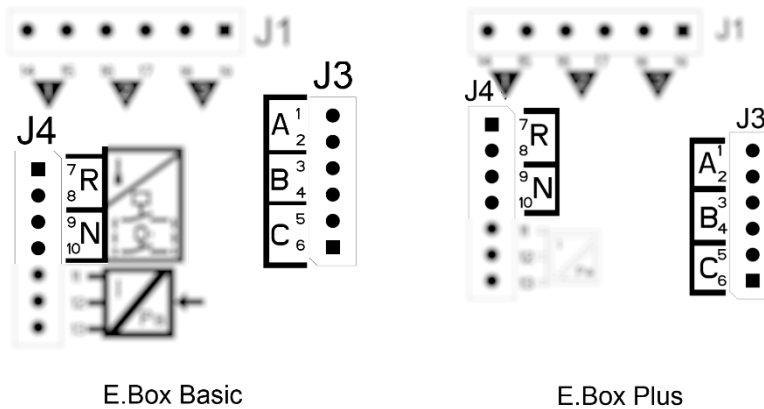

Figure 32: Position of inputs and alarms

**Motor thermal protection:** the E.box has an input for the thermal protection of each motor. If the motor used is provided with thermal protection, this protection can be connected to the terminals KK. If the protection is not present in the motor, the terminals must be jumpered. For the position of the terminals, see Figure 33.

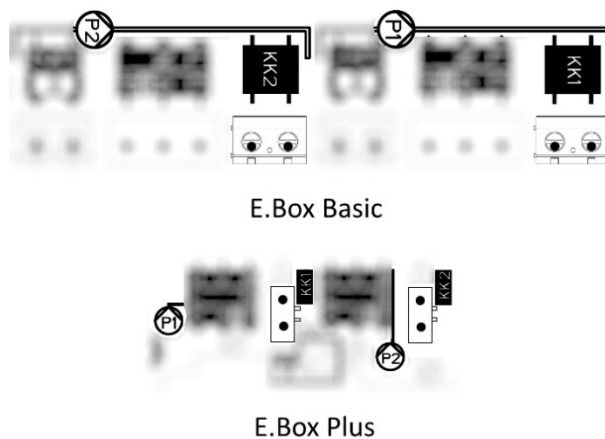

Figure 33: Thermal protection inputs KK

#### 7.4 Connection of the alarm outputs

If alarms occur, this is indicated by the E.box in three ways:

- With the leds on the front panel, which give a number of blinks depending on the error.
- With the outputs Q1, Q2, Q3 which short circuit as specified in Table 17. The operating logic of the alarms is as follows: Q1 closes following malfunctions of pump 1, Q2 of pump 2 and Q3 for general errors.
- With the indications on the display (if present). In this case it is also possible to see the alarm log.

If the panel is not fed, Q1, Q2 and Q3 are closed, so they give an alarm signal.

### 7.5 Connection of floats or level probes

2 or 3 control inputs can be used which must be connected as follows:

- **System with 2 floats or level probes:** in this case inputs B and C are used. Terminal A must be left free. The floats in the tank must be connected as in Figure 31. For electrical installation, see Figure 34 Inputs.
- **System with 3 floats or level probes:** in this case inputs A, B and C are used. The floats in the tank must be connected as in Figure 31: drainage system diagram. For electrical installation, see Figure 34 Inputs.

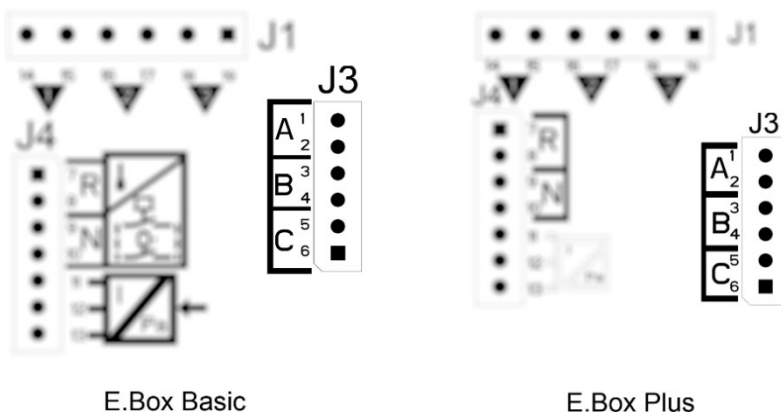

Figure 34: Inputs



**Common contact of the inputs.** There is only one common contact for all the inputs and it is connected to the even terminals from 2 to 10. So, if level probes or electric probes are used, the common contact for the inputs A, B, C, R, N must be connected to the terminals with even numbers: 2, 4, 6, 8, 10.

**Level probes:** use them only with clear, clean water.

### 7.6 Depth sensor connection

The E.Box may use a depth sensor as a control device. If an E.box with a display is used, the too high or too low level alarms can be read by the depth sensor. So it is not necessary to connect floats or level probes to the inputs R or N. If maximum reliability is desired, as well as the depth sensor 2 floats or level probes can also be used, for the alarms R and N.

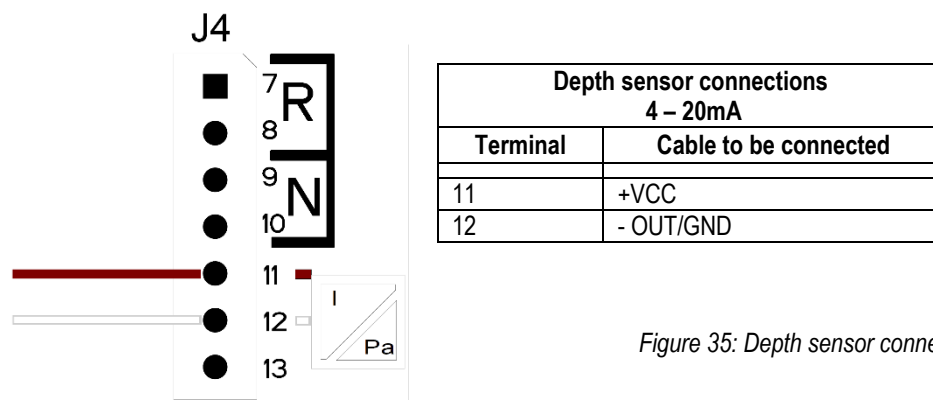

Figure 35: Depth sensor connection

The depth sensor must be positioned near the bottom of the tank, ensuring that it is above any solid residue or impurities, present or future.



**ATTENTION:** incorrect wiring of the sensor can damage the appliance and the sensor.

### 7.7 Setting with the display, wizard

The E.Box D can be configured with a simple wizard. The device asks the user for all the parameters necessary for its configuration. If necessary, it can be loaded by pressing the “set” + “+” keys when switching on. To navigate in the wizard, use the following keys:

- “mode” to accept the parameter displayed and move on to the next,
- “mode” held down for more than 1 second to return to choose the parameter,
- “-“ e “+” to vary the value of the parameter.

7.8 Configuration of floats or level probes



Figure 36: Configuration of Drainage floats or level probes

After configuration, the system status will be one of those shown in Figure 37, depending on whether level probes or floats are used.

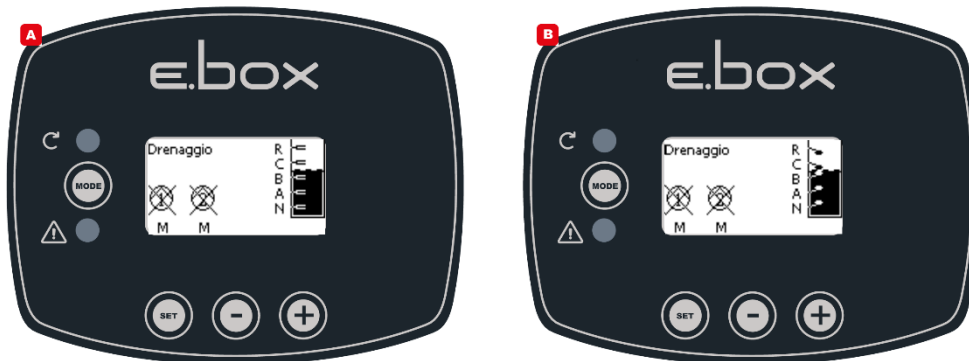

Figure 37: System status in drainage mode, A with level probes. B with floats

7.9 Configuration with a depth sensor



Figure 38: Configuration with only a depth sensor

In point 7 it is possible to choose the type of signal that will generate the maximum and minimum level alarms. Floats, level probes or the data provided by the depth sensor may be used. If the depth sensor is used, the maximum ML and the minimum LL level alarm thresholds must be set in accordance with Figure 43. The installation sequence with only the depth sensor is shown.

**System status and starting**



Figure 39: System status in configurations: A with only depth sensor, B: depth sensor and floats, C depth sensor and level probes

**7.10 Setting the E.box with dip switches**

If the E.box is provided with a display, it is recommended to use the display for configuration. Otherwise it is possible to use the dip switches inside the panel and set them as shown in Figure 40 Setting dip switches for drainage.

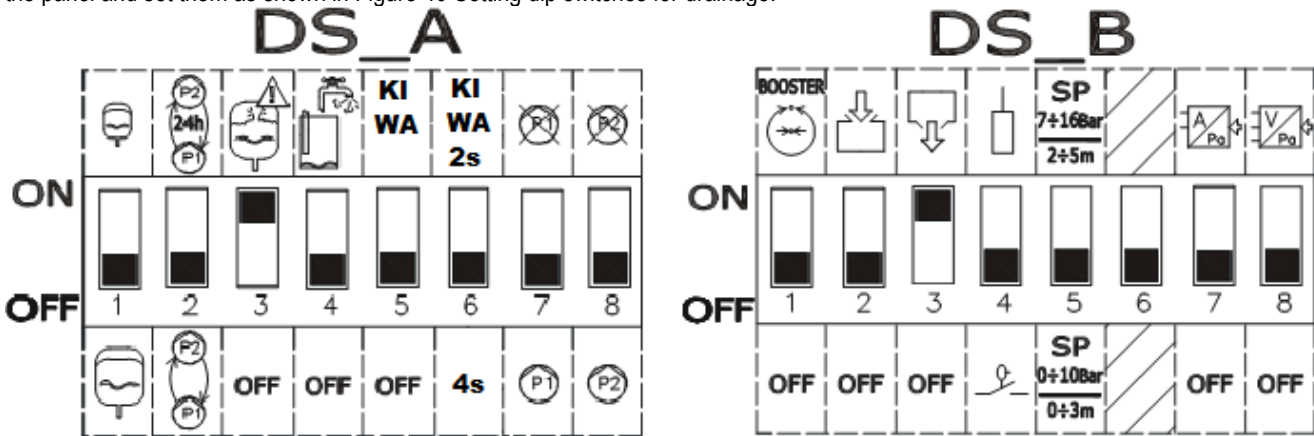

Figure 40: Setting the Drainage dip switches

**7.11 Activation of the set**



To activate the set it is necessary to enable the pumps. During the first configuration, for safety's sake, the pumps are disabled and are OFF. To change to automatic mode, just briefly press the  buttons on the pumps P1 and P2. As shown in Figure 41.

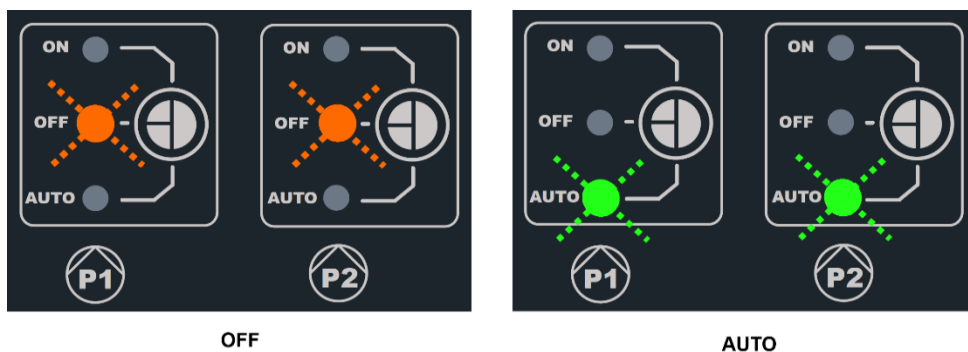

Figure 41: Enabling P1 and P2.

The following modifications may be made during configuration:

- If you want the pumps to be exchanged every 24 hours and not at each restart, set **DS\_A2** at ON.
- If you do not want protection against too rapid restarts, set **DS\_A3** at OFF.
- If you do not want to use the pump P1 set **DS\_A7** at ON.
- If you do not want to use the pump P2 set **DS\_A8** at ON.

- If level probes are used and not floats, set **DS\_B4** at **ON**
- If a depth sensor is used, set **DS\_B7** at **ON** and position **DS\_B5** according to the desired scale.

**7.12 Regulating the rated current of the pumps (Imax) and the pump starting and stopping levels (only with depth sensor connected)**

With a straight tip screwdriver, position the indices in the centre of the graduated scales, as shown, so that:

- Imax indicates the rated current of the installed pumps, which you can find on the pump data plate.
- SP represents the maximum level in the tank (LMAX) that you want the water to reach during normal operation.
- DP represents the minimum level in the tank (LMIN) that you want the water to reach during normal operation. DP is expressed as a percentage of SP.



Attention, SP and DP have significance only if a depth sensor is used. For their meaning, refer to Figure 43. The scale adapting label must be applied on SP.

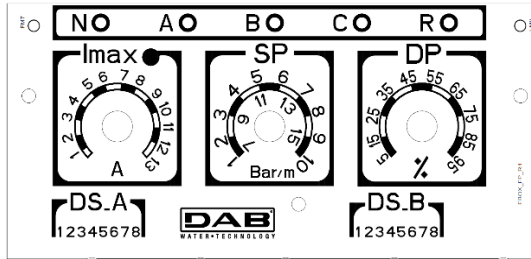

Figure 42: Regulating the rated current SP and DP

**7.13 System operation:**

**Operation with 2 floats or level probes**

The operating logic is the following:

- Float or level probe connected to input B starts P1 and stops both pumps.
- Float or level probe connected to input C starts pump P2.

Filling operation with 2 floats		
	Start	Stop
Pump P1	Float or level probe on B = CLOSED	Float or level probe B = OPEN
Pump P2	Float or level probe C = CLOSED	Float or level probe B = OPEN

Table 8: Filling operation with 2 floats

**Operation with 3 floats or level probes**

The operating logic is the following:

- Float or level probe connected to input B starts pump P1.
- Float or level probe connected to input C starts pump P2.
- Both pumps are stopped on the float or level probe connected to A.

Filling operation with 3 floats		
	Start	Stop
Pump P1	Float or level probe on B = CLOSED	Float or level probe on A = OPEN
Pump P2	Float or level probe C = CLOSED	Float or level probe on A = OPEN

Table 9: Filling operation with 3 floats



**Note:** the function with 3 floats is used in installations with deep narrow tanks that do not allow an ample travel of the floats!

**Note:** in the E.box version with display, the correct number of floats or level probes used is displayed automatically.

**Operation with depth sensor and display**

If a depth sensor is being used, with an E.box with display, it will be possible to set independently the starting level of pump P1, of pump P2, and the stopping level of both. In particular:

- HA is the stopping level of the pumps P1 and P2
- HB is the starting level of pump P1
- HC is the starting level of pump P2

It will also be possible to set the alarm levels for maximum and minimum level. The minimum settable level (including the minimum alarm level) cannot be lower than 15 cm. The maximum settable level (including the maximum alarm level) cannot be higher than the tank height minus 5 cm. The various levels are separated from one another by a minimum of 5 cm.

**Operation with depth sensor without display**

In operation with a depth sensor, the parameters must be set with the Trimmers SP and DP, see Figure 42.

- SP represents the maximum level in the tank ( $L_{MAX}$ ) that you want the water to reach during normal operation.
- DP represents the minimum level in the tank ( $L_{MIN}$ ) that you want the water to reach during normal operation. DP is expressed as a percentage of SP.

If the level in the tank is the same as or higher than SP, the pump P1 is started and, if the level continues to rise, pump P2 is also started after a delay of 4 seconds.

When level DP is reached, both pumps stop.

The following table sums up the behaviour described:

Drainage with depth sensor, without display		
	STARTING	STOPPING
P1	Tank level $\geq$ SP	Tank level = DP
P2	Pump P1 = started for at least 4 seconds and tank $\Rightarrow$ SP	Tank level = DP

Table 10: Drainage with depth sensor, without display

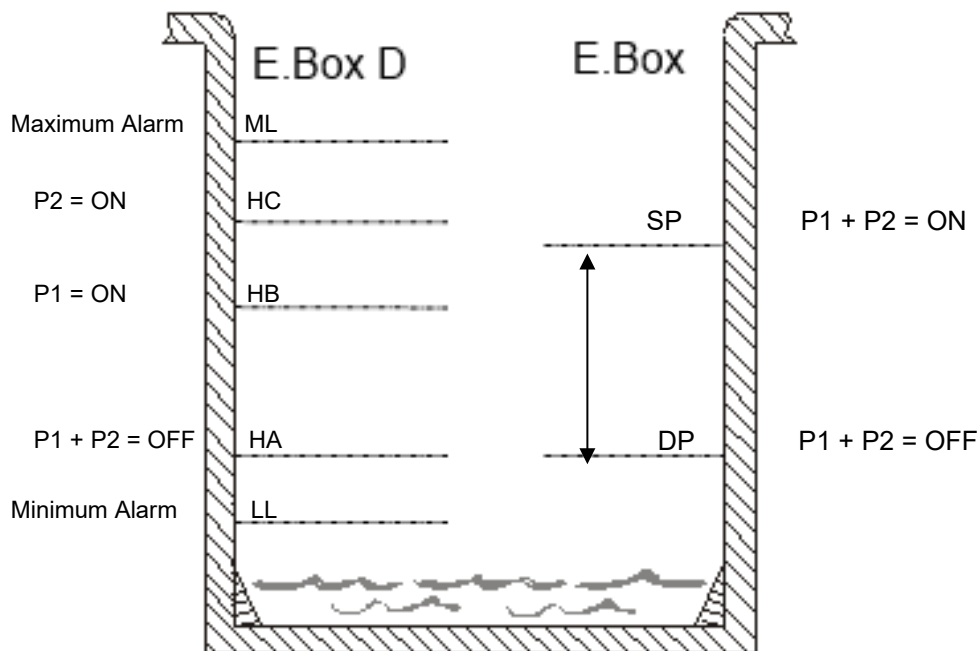

Figure 43: Drainage with a depth sensor

E.box with display

E.box without display

**8 KIWA PRESSURE BOOSTING FUNCTION**

The E.box panel can be used for making a system to increase water pressure that respects the KIWA standard. This mode is available only if the language chosen is French, Dutch or English. As control inputs, either pressure switches or a pressure sensor can be used. A pressure switch for low pressure must be used to put at the intake of the set.

**8.1 Expansion vessel**

In KIWA pressure boosting it is necessary to use an expansion vessel of at least 19 litres per pump.

**8.2 Electrical connections of pump and supply**

Connect the supply line and the pumps as described in chapter 2.1.

**8.3 Connection of additional protections: high pressure and motor thermal protection**

It is possible, but not necessary, to use the alarm inputs to the E.box so that the pumps stop in the case of pressure that is too high or too high motor temperature. In the case of an alarm, the pumps stop, the alarm LEDs blink, the corresponding alarm outputs are activated. If the display is present, the type of alarm is indicated. When the alarm conditions no longer exist, the E.box resumes normal operation.



- **Alarm, Pressure in system too high:** the pressure switch must be installed in the delivery of the set. The normally closed contact of the pressure switch must be connected to terminal R of the E.box. The pressure switch must be set at the maximum pressure that can be reached by the system in safe conditions. If it is not used, the contact is jumpered.

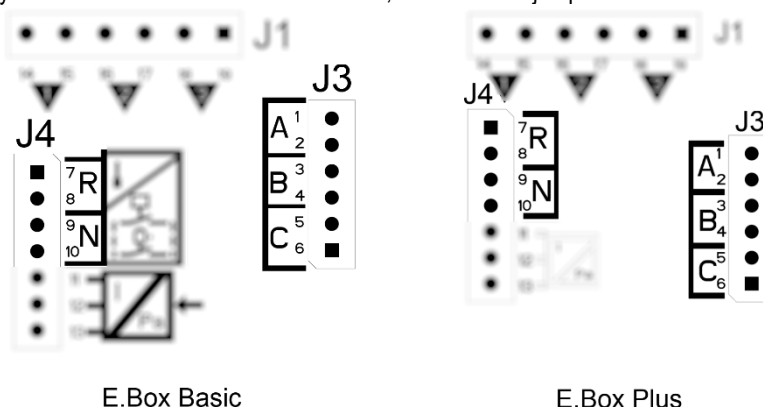

Figure 44: Inputs

- **Motor thermal protection:** the device has an input for the thermal protection of each motor. If the motor used is provided with thermal protection, this protection can be connected to the terminals KK. If the protection is not present in the motor, the terminals must be jumpered. The terminals are shown in Figure 45.



If the alarms are not used, they must be jumpered. So jumpers must be fitted on the inputs of the contacts R, KK1 and KK2.

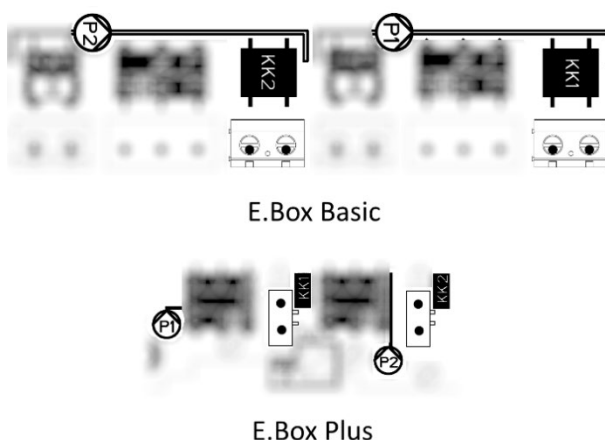

Figure 45: Thermal protection inputs KK

#### 8.4 Connection of the alarm outputs

If alarms occur, this is indicated by the E.box in three ways:

- With the leds on the front panel, which give a number of blinks depending on the error.
- With the outputs Q1, Q2, Q3 which short circuit as specified in Table 17. The operating logic of the alarms is as follows: Q1 closes following malfunctions of pump 1, Q2 of pump 2 and Q3 for general errors.
- With the indications on the display (if present). In this case it is also possible to see the alarm log.

If the panel is not fed, Q1, Q2 and Q3 are closed, so they give an alarm signal.

#### 8.5 Operation with pressure sensor (recommended choice)

It is recommended to use this operating mode, rather than pressure switches, because it allows greater flexibility in managing the system, the pressure distributed by the set can be seen, and installation is easier. In this case it will be possible to set the Set Point pressure and the pressure differential for the restarting and stopping of the pumps.

#### 8.6 Connection of the pressure sensor

The pressure sensor must be connected to the terminal board, see Figure 46, according to the following diagram:



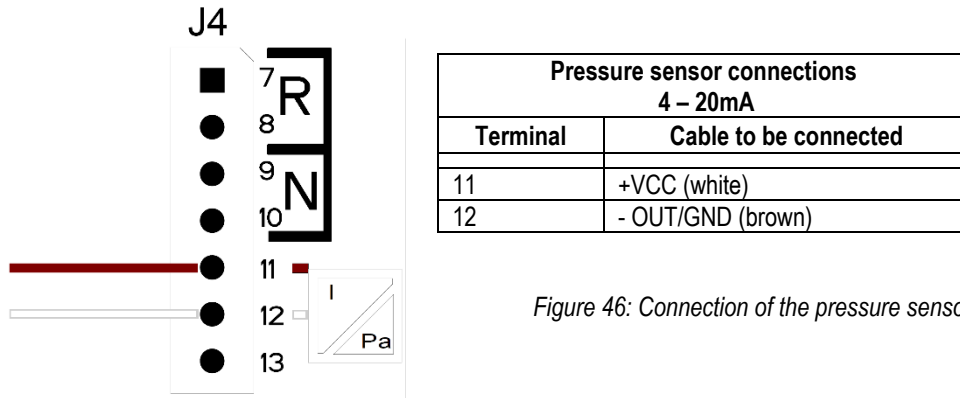

Figure 46: Connection of the pressure sensor 4..20mA



**ATTENTION:** incorrect wiring of the sensor can damage the appliance and the sensor.

**NOTE:** the choice of sensor limits the maximum set-point that can be reached.

### 8.7 Operation with pressure switches

If you decide to operate the booster set with pressure switches, they must be connected on the delivery of the booster set. The pressure switches to be used are B and C and they are connected as indicated in the next paragraph.

### 8.8 Connection of pressure switches

The pressure switches must be connected to the contacts B and C of the terminal board shown in Figure 47.

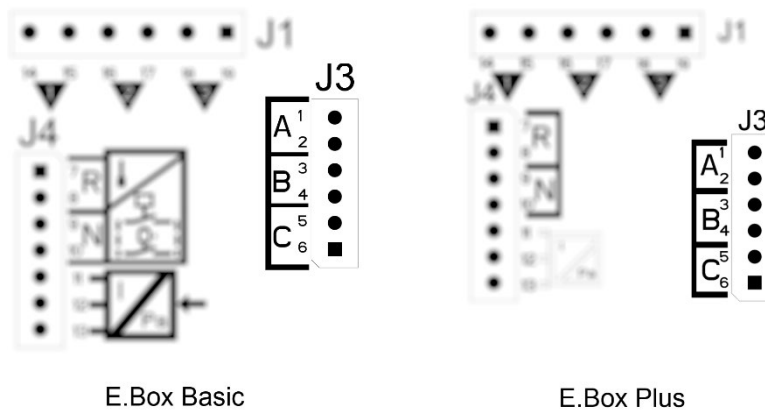

Figure 47: Pressure switch terminal board

### 8.9 Connecting the low-pressure pressure switch

To comply with the KIWA standard it is necessary to connect a low-pressure pressure switch on the pump intake, set at such a pressure that it intervenes in the event of water lack.

The pressure switch must be connected to contact N of the E.Box and the contact must open if the pressure falls below the minimum value. If the KIWA low pressure alarm trips, the set stops and it can be reset only manually, as required by the KIWA standard.

### 8.10 Setting with the display, wizard

The E.box D can be configured with a simple wizard. The device asks the user for all the parameters necessary for its configuration. If necessary, it can be loaded by pressing the “set” + “+” keys when switching on. To navigate in the wizard, use the following keys:

- “mode” to accept the parameter displayed and move on to the next,
- “mode” held down for more than 1 second to return to choose the parameter,
- “- e +” to vary the value of the parameter.

8.11 Setting with a pressure sensor:



Figure 48: KIWA pressure boosting with pressure sensor

8.12 Configuration with pressure switches:

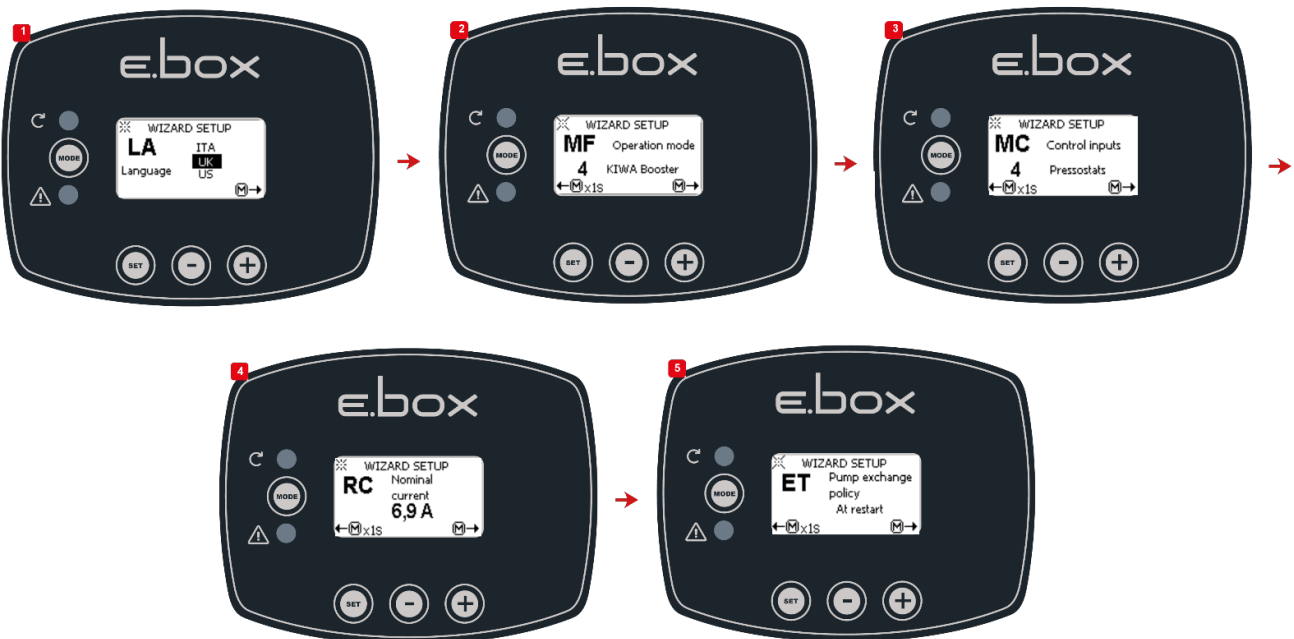

Figure 49: Kiwa configuration with pressure switches

8.13 System status in Kiwa mode

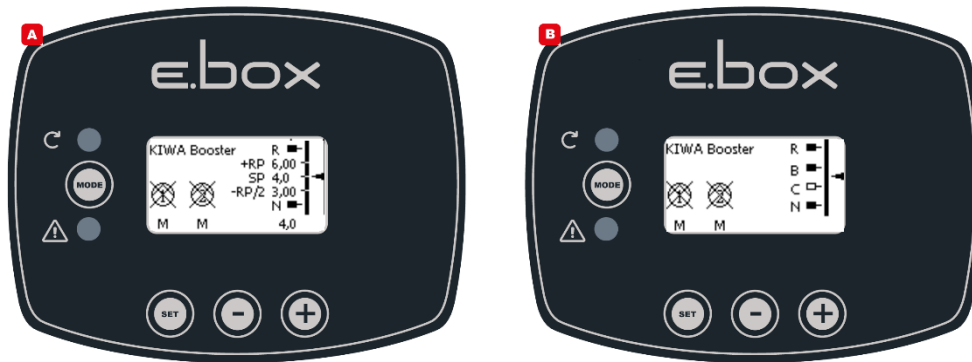

Figure 50: System status in KIWA mode

8.14 Setting the E.box with dip switches

If the E.box is provided with a display, it is recommended to use the display for configuration. Otherwise it is possible to use the dip switches inside the panel and set them as shown in Figure 51.

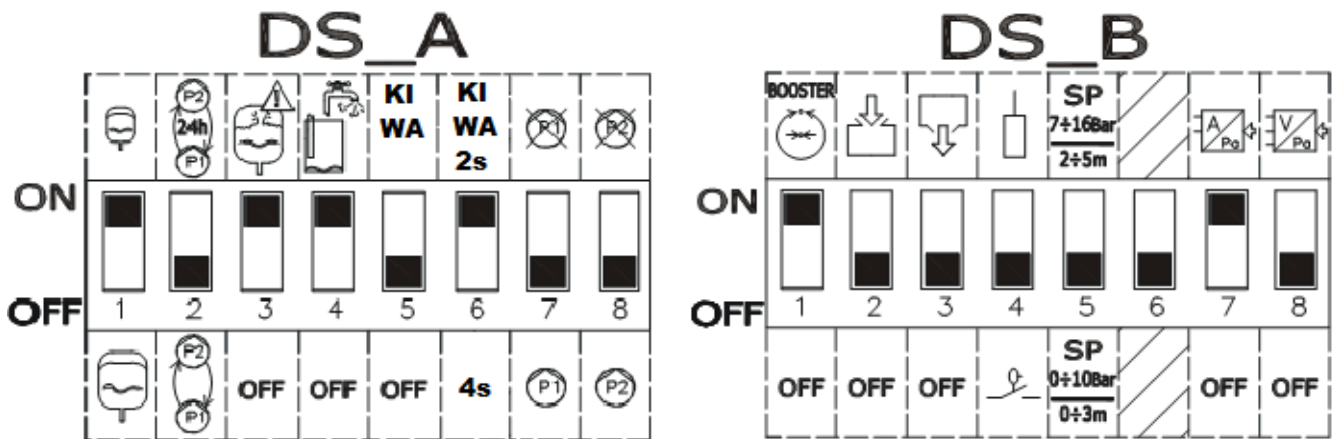
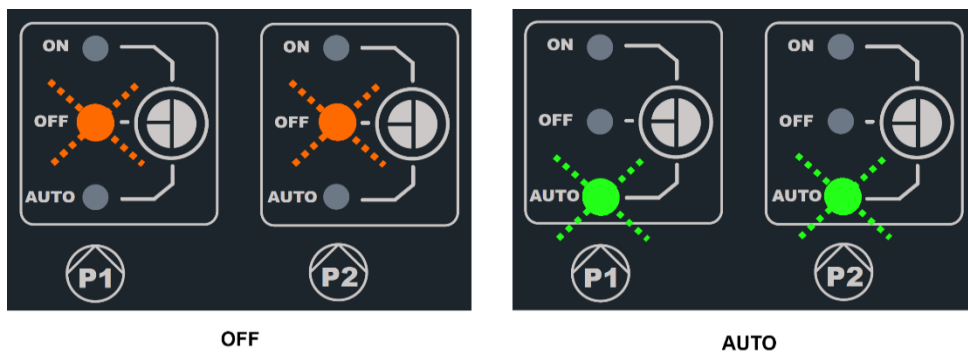

Figure 51: Dip switches for KIWA pressure boosting

8.15 Activation of the set



To activate the set it is necessary to enable the pumps. During the first configuration, for safety's sake, the pumps are disabled and are OFF. To change to automatic mode, just briefly press the  buttons on the pumps P1 and P2. As shown in Figure 52.



OFF

AUTO

Figure 52: enabling P1 and P2

**The following modifications may be made during configuration:**

- If the expansion vessel is larger than 100 litres, set **DS\_A1** at **OFF**.
- If you want the pumps to be exchanged every 24 hours and not at each restart, set **DS\_A2** at **ON**.
- If you do not want protection against too rapid restarts, set **DS\_A3** at **OFF**.
- If you do not want protection against lack of water, set **DS\_A4** at **OFF**.
- If you want to bring the delay in switching off the pumps from 2 to 4 seconds, set **DS\_A6** at **OFF**.
- If you do not want to use the pump P1 set **DS\_A7** at **ON**.
- If you do not want to use the pump P2 set **DS\_A8** at **ON**.
- If you intend to use a set-point between 7 and 16 bar, set **DS\_B5** at **ON**.
- If you intend to use pressure switches, set **DS\_B7** at **OFF**.

**8.16 Regulating the rated current of the pumps (Imax), Set point (SP) and differential restarting pressure (DP)**

With a straight tip screwdriver, position the indices in the centre of the graduated scales, as shown in Figure 53, so that:

- **Imax** indicates the rated current of the installed pumps, which you can find on the pump data plate.
- **SP** indicates the desired set point pressure.
- **DP** is the pressure variation, in percentage of the set point, necessary to restart the pumps.



Attention, the differential restarting pressure is calculated as  $SP * DP$ . If the set point is 4 bar and DP is 50%, the pressure differential RP is 2 bar.

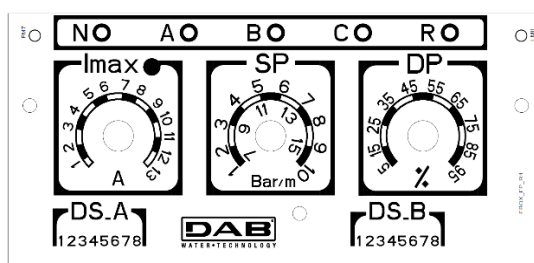

Figure 53: Regulating the rated current SP and DP

**8.17 System operation**

**Pressure switches:**

The operating logic is the following:

- Pressure switch connected to input B starts and stops Pump 1.
- Pressure switch connected to input C starts and stops Pump 2.

Pressure boosting operation with pressure switches		
	Start	Stop
<b>P1</b>	Pressure switch B = CLOSED	Pressure switch B = OPEN
<b>P2</b>	Pressure switch C = CLOSED	Pressure switch C = OPEN

Table 11: Pressure boosting operation with pressure switches

**Pressure sensor:**

RP is the pressure differential, and indicates the pressure variation around the Set Point for which the pumps are switched on. In systems with a display it is set directly. In systems without a display, DP is set as a percentage of the Set Point.  $RP = SP * DP$ . For further information see Figures 54 and 55.

The operating logic is the following:

- The first pump starts when the pressure falls below the Set Point and it stops when it reaches the Set Point pressure + RP.
- The second pump starts when the pressure falls below the Set Point minus RP, or 2% of the Set Point if vessels over 100 litres are used. It stops when the set point pressure + RP is reached in the system.

Pressure boosting operation standard vessel < 100 litres		
Pumps	Start	Stop
P1	System pressure $\leq$ SP	System pressure $\Rightarrow$ SP+RP
P2	System pressure $\leq$ SP - RP	System pressure $\Rightarrow$ SP+RP

Table 12: Pressure boosting operation standard vessel < 100 litres

Operation with additional expansion vessel > 100 litres		
Pumps	Start	Stop
P1	System pressure $\leq$ SP	System pressure $\Rightarrow$ SP+RP
P2	System pressure $\leq$ SP - 2%	System pressure $\Rightarrow$ SP+RP

Table 13: Operation with additional expansion vessel > 100 litres



Attention: If DIP SWITCH configuration is used, the differential restarting pressure is calculated as  $SP * DP$ . If the set point is 4 bar and DP is 50%, the restarting pressure RP is 2 bar.

The names pump P1 and P2 are only indicative. If exchange mode is activated, the pumps P1 and P2 are alternated as specified in the exchange mode.

The two pumps will always be started alternately with a minimum interval of 2 seconds from each other.

Example

of Regulation with Standard expansion vessel and Regulation with additional expansion vessel:

SP= 4 bar

RP = 2 bar Attention: if DP is set (with the trimmers)  $RP=SP*DP$



Figura 54: Regulation with expansion vessel < 100 litres



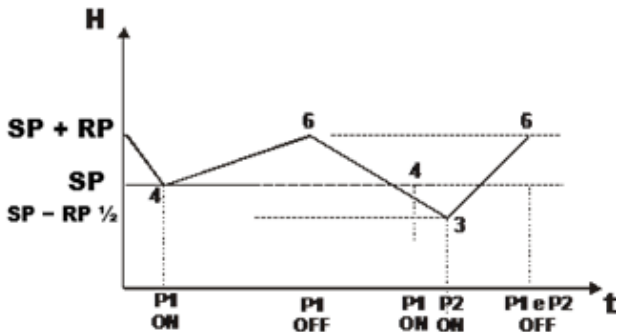

Figura 55: Regulation with expansion vessel > 100 litres

9 THE KEYPAD AND THE DISPLAY

Main display of the E.Box.

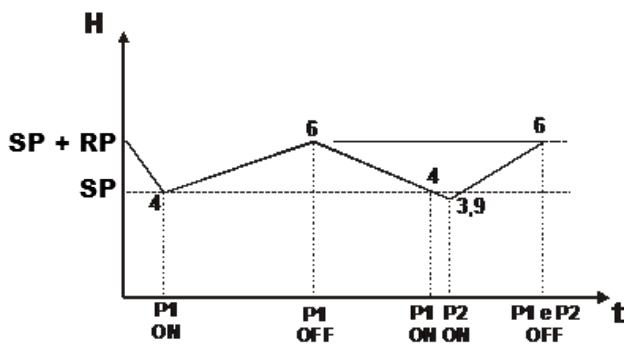

Figure 56: Label and keys

	<p>If it refers to a pump, the RESET Eliminate alarms key eliminates the errors of that pump. If it is general, it eliminates the panel errors.</p>
	<p>It allows you to choose the operating mode of the pumps P1 and P2. ON pump always on, OFF pump always off. In AUTO mode the panel decides when to switch the pumps on or off. To pass to ON mode, you must hold down the key for at least 3 seconds. When the key is released, the pump returns to the previous mode.</p>

The number of blinks of the leds next to the alarm symbol represents the type of error. There is a legend on the label.

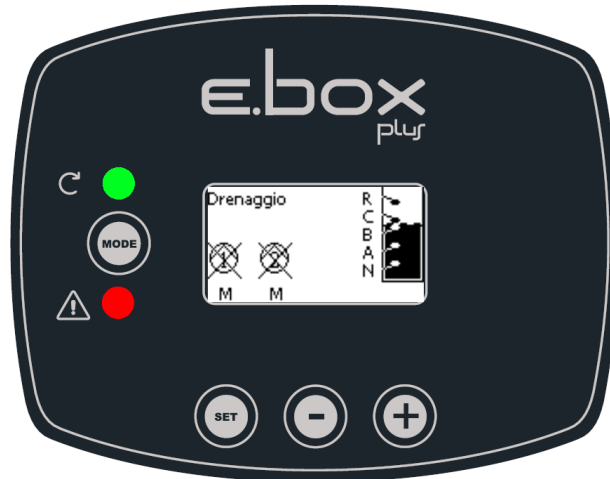

Figure 57: Label, keys and display

E.box display label. The functions of the keys are summed up in Table 14.





	The MODE key allows you to move on to the next items in the same menu. Holding it down for at least 1 sec allows you to skip to the previous menu item.
	The SET key allows you to leave the current menu.
	Decreases the current parameter (if it is an editable parameter). The decreasing speed increases as time passes.
	Increases the current parameter (if it is an editable parameter). The increasing speed increases as time passes.

Table 14: Key functions

### 9.1 Status line

When viewing the parameters, at the bottom of the display, there is the system status, showing the status of the pumps, the status of the floats if present, and the status of the sensors if present. See Figure 58: Selection of the drop-down menus.

### 9.2 Menus

The complete structure of all the menus and of all the items of which they are composed is shown in Table 16.

### 9.3 Access to the menus

The various menus can be accessed from the main menu in two ways:

1. Direct access with a combination of keys.
2. Access by name with a drop-down menu.

#### Direct access with a combination of keys

The desired menu can be accessed directly by pressing simultaneously the appropriate combination of keys (for example MODE SET to enter the Set Point menu) and the various items in the menu are scrolled with the MODE key.

Table 15 shows the menus that can be reached with the combinations of keys.

ENGLISH

















MENU NAME	DIRECT ACCESS KEYS	HOLD-DOWN TIME
User		On releasing the button
Monitor	 	2 Sec
Setpoint	 	2 Sec
Installer	  	5 Sec
Technical assistance	  	5 Sec
Reset factory values	 	2 sec after switching on appliance
Reset	   	2 Sec

Table 15: Access to the menus

<b>Main Menu</b>	<b>User Menu</b> <i>mode</i>	<b>Monitor Menu</b> <i>set-minus</i>	<b>Setpoint Menu</b> <i>mode-set</i>	<b>Installer Menu</b> <i>mode-set-minus</i>	<b>Tech. Assist. Menu</b> <i>mode-set-plus</i>
<b>MAIN</b> (Main Page)	<b>VP</b> Pressure/level	<b>FF</b> Fault & Warning Log	<b>SP</b> Setpoint pressure	<b>RC</b> Rated current:	<b>TB</b> Water lack blockage time
Menu Selection	<b>C1</b> P1 phase current	<b>CT</b> Contrast	<b>RP</b> Pressure differential	<b>MF</b> Operating mode	<b>T1</b> Low pressure delay
	<b>C2</b> P2 phase current	<b>LA</b> Language	<b>HC</b> P2 starting level	<b>MC</b> Control devices	<b>T2</b> Switch-off delay
	<b>PO1</b> Power P1	<b>HS</b> System on hours	<b>HB</b> P1 starting level	<b>GS</b> Protection devices	<b>ET</b> Exchange mode
	<b>PO2</b> Power P2	<b>H1</b> P1 on hours	<b>HA</b> Stopping level	<b>PR</b> Type of sensor used	<b>AL</b> Anti-leakage
	<b>VE</b> HW and SW information	<b>H2</b> P2 on hours		<b>MS</b> Measuring system	<b>AB</b> anti-blocking drainage
	<b>SN</b> Serial			<b>SO</b> Dry running factor	<b>TH</b> Tank height
				<b>MP</b> Minimum pressure threshold	<b>ML</b> Maximum level alarm
				<b>OD</b> Expansion vessel size	<b>LL</b> Minimum level alarm
				<b>EP</b> Exclude pump	<b>PS</b> Power supply system
					<b>RF</b> Reset fault & warning
					<b>PW</b> Change password



Legend	
Identifying colours	Notes on the parameters
	Only in pressure boosting with active pressure sensor
	Only if a pressure or depth sensor is used
	Only in kiwa mode
	Only in filling or drainage with a depth sensor
	Read-only parameters.

Table 16: Menu structure

### Access by name with a drop-down menu

The selection of the various menus is accessed by name. The menu selection is accessed from the main menu by pressing “+” or “-“. The names of the menus that can be accessed appear on the menu selection page and one of the menus is highlighted by a bar (see Figure 58). Shift the highlighting bar using the “+” and “-“ keys to select the menu you want and enter it by pressing SET.

```

SELEZIONE MENÙ
MENU' PRINCIPALE
MENU' UTENTE
MENU' MONITOR
P1:M P2:M NR 0,78 m

```

Figure 58: Selection of the drop-down menus

The menus displayed are MAIN, USER, MONITOR, followed by a fourth item, EXTENDED MENU; this item allows the number of menus displayed to be extended. When EXTENDED MENU is selected a pop-up appears asking you to type in an access key (PASSWORD). The access key (PASSWORD) coincides with the combination of keys used for direct access and allows the extended display of the menus from the menu corresponding to the access key to all those with a lower priority.

The order of the menus is: User, Monitor, Setpoint, Installer, Technical Assistance.

When an access key is selected, the menus released remain available for 15 minutes or until they are disabled manually by means of the item “Hide forward menus” which appears on the menu selection when using an access key.

## 9.4 MEANING OF THE INDIVIDUAL PARAMETERS

### 9.4.1 USER MENU

From the main menu, pressing the MODE key (or using the selection menu and pressing “+” or “-“), gives access to the USER MENU. In this menu, the following values are displayed in sequence.

#### VP: Pressure display

Plant pressure measured in [bar] or [psi] depending on the measuring system used, or level of the liquid in the tank. Available only if the pressure or depth sensor is used.

#### C1: Display of the phase current of pump P1

Phase pump of the electropump connected as P1 in [A].

#### C2: Display of the phase current of pump P2

Phase pump of the electropump connected as P2 in [A].

#### PO1: Display of the power absorbed by pump P1

Power delivered to the electropump P1 in [kW].

#### PO2: Display of the power absorbed by pump P2

Power delivered to the electropump P2 in [kW].

#### VE: System monitor

Displays the system status, the hardware and software release of the E.Box can be displayed.

#### SN: Serial

Displays the serial number assigned to the panel by the DConnect Box.

### 9.4.2 MONITOR MENU

From the main menu, by holding down simultaneously for 2 sec the keys “SET” and “-“, or using the selection menu and pressing “+” or “-“, you can access the MONITOR MENU.

In this menu, by pressing the MODE key, the following values are displayed in sequence.

**FF: Fault log display**

Chronological display of the faults that have occurred during system operation.

For each fault the following are displayed:

- A symbol for the area concerned: the panel, pump P1 or pump P2.
- The type of error or alarm, summed up in a code. See Table 19).
- The number of times the error has occurred.
- A text description of the error or alarm.
- The time of switching on the panel or of pump operation at which the error occurred.

The order of the error in the log and the number of errors in the memory.

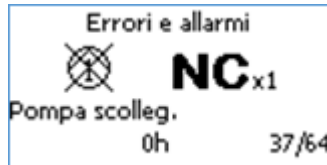

Figure 59: Errors in the memory

The faults are displayed in chronological order starting from the oldest one. The last one that occurred is shown first. The maximum number of faults that can be displayed is 64; if the number of errors is greater, the oldest ones are overwritten.

**CT: Display contrast**

Adjusts the display contrast.

**LA: Language**

Changes the language used on the display. Attention, Kiwa mode is present only if the language is Dutch, French or English UK and US.



**Note:** If US is selected, the E.Box will use English with Imperial measurements.

**HS: System operating hours**

Indicates the hours the system has been on.

**H1: Pump P1 operating hours**

Indicates the hours the pump P1 has been on.

**H2: Pump P2 operating hours**

Indicates the hours the pump P2 has been on.

**9.4.3 SETPOINT MENU**

From the main menu, hold down simultaneously the "MODE" and "SET" keys until "SETPOINT MENU" appears on the display (or use the selection menu pressing "+" or "-"). In this menu the parameters displayed depend on the type of application.

**SP: Setting the Set Point pressure (only in pressure boosting and in KIWA pressure boosting with pressure sensor)**

Pressure Set Point at which the E.Box keeps the plant under pressure. It can vary between 1 bar (14 psi) and the full-scale value of the sensor minus 2 bar (28 psi).

**RP: Setting the Pressure Differential (only in pressure boosting and in KIWA pressure boosting with pressure sensor)**

Pressure differential in which the E.Box panel maintains the pressure in the plant. See chapter on pressure boosting.

It can vary between 5% and 95% of SP. SP + RP cannot exceed the full-scale value of the sensor. See chapter on pressure boosting.

**HC: Pump P2 starting level (only in drainage or filling with depth sensor)**

Starting level of pump P2.

**HB: Pump P1 starting level (only in drainage or filling with depth sensor)**

Starting level of pump P1.

**HA: Pumps stopping level (only in drainage or filling with depth sensor)**

Stopping level of pumps P1 and P2.

**9.4.4 INSTALLER MENU**

From the main menu, hold down simultaneously the "MODE" and "SET" keys until "INSTALLER MENU" appears on the display (or use the selection menu pressing "+" or "-"). The menu allows you to view and modify various configuration parameters: the MODE key allows you to scroll through the menu pages, the "+" and "-" keys allow you respectively to increase and decrease the value of the parameter concerned. Press SET to leave this menu and return to the main menu.

Also in this menu, different parameters may be seen depending on the operating mode.

**RC: Setting the rated current of the electropump**

Rated current absorbed by the pumps in Ampere (A). The rated current of the pumps used must be set. The rated current refers to the type of connection used, star or delta or single-phase. If 2 pumps are used, they must be identical.

**MF: Operating mode**

This parameter expresses the operating mode of the E.Box. KIWA pressure boosting mode is available only if the language selected is Dutch, French or English. If the operating mode is changed, the wizard starts automatically with the request for the parameters that have not been configured.

**MC: Control devices**

This parameter allows you to choose the type of inputs that inform the E.Box about the system status. The inputs may be floats, level probes, pressure sensors or depth sensors, depending on the type of application.

**GS: Protection devices (only in drainage or filling or with depth sensor)**

This parameter allows you to choose the type of inputs that inform the E.Box about anomalous conditions of the system. The inputs may be floats, level probes or the depth sensor.

**PR: Type of sensor used (only if a pressure or depth sensor is used)**

This parameter allows you to choose the type of sensor connected to the E.Box.

**MS: Measuring system**

This parameter allows you to choose the type of measuring system used to express the values on the display. The values may be expressed with the metric system or with the imperial system.

**SO: Dry running factor**

Sets a minimum threshold of the dry running factor below which the lack of water is detected. The dry running factor is a non-dimensional parameter obtained from the combination of the absorbed current and the power factor of the pump. Thanks to this parameter it can be correctly established when a pump has air in the impeller or when the intake flow is interrupted.

If you want to use this type of protection against dry running, the parameter TB (block time for lack of water) must be set at a value other than zero.

To set the SO threshold, it is recommended to perform the following tests (with parameter TB at 0):

- run the pump at a low flow rate and memorise the SO value read
- run the pump dry.

Set TB at the desired value and set SO halfway between the 2 values read in the 2 previous situations.

**MP: Minimum pressure threshold (only in pressure boosting and KIWA pressure boosting)**

Sets a minimum pressure for switching off due to water lack. If the pressure in the plant arrives at a pressure below the MP, the water lack signal is given. This too requires a TB value other than 0 to be active.

**OD: Expansion vessel size (only in pressure boosting and KIWA pressure boosting)**

Allows you to set the size of the expansion vessel.

**EP: Pump exclusion**

Allows you to exclude one or both pumps; useful if only one pump is connected to the E.Box panel.

**9.4.5 TECHNICAL ASSISTANCE MENU**

From the main menu, hold down simultaneously the "MODE" and "SET" and "-" keys until "TECHNICAL ASSISTANCE MENU" appears on the display (or use the selection menu pressing "+" or "-"). The menu allows you to view and modify various configuration parameters: the MODE key allows you to scroll through the menu pages, the + and - keys allow you respectively to increase and decrease the value of the parameter concerned. Press SET to leave this menu and return to the main menu. Also in this menu, different parameters may be seen depending on the operating mode.

**TB: Water lack blockage time**

Sets the time for which the water lack signal must persist in order to give the alarm.

**T1: Switch-off time after the low pressure signal (only in pressure boosting and KIWA pressure boosting)**

Sets the time for which the low pressure signal must persist in order to give the alarm. This parameter is useful in KIWA mode.

**T2: Switch-off delay time (only in KIWA pressure boosting)**

Sets the delay with which the pumps switch off after switch-off conditions have been reached.

**ET: Exchange mode**

Sets the mode with which the pumps are exchanged. You can choose not to exchange them, to do it when restarting, or to do it after a period of time.

**AL: Anti-leakage**

If anti-leakage is set, there will not be more than 8 starts per minute, per pump.

**AB: Anti-blocking (only in drainage)**

Starts the pumps for a few moments, if they have not been on for the time set in this parameter. This function is used to prevent blocking of the pumps due to long inactivity. This function is available only in drainage.

**TH: Tank height (only in filling or drainage mode with a depth sensor)**

Allows you to set the tank height, if the E.Box is being used in filling or drainage mode together with a depth sensor.

**ML: Maximum level alarm (only in filling or drainage mode with a depth sensor)**

Allows you to set what will generate the maximum level alarm. You can choose a separate device, such as a float or a level probe, or have the alarm given by the sensor used to start the pumps. In this case you can also set the level that generates the alarm.

**LL: Minimum level alarm (only in filling or drainage mode with a depth sensor)**

Allows you to set what will generate the minimum level alarm. You can choose a separate device, such as a float or a level probe, or have the alarm given by the sensor used to start the pumps. In this case you can also set the level that generates the alarm.

**PS: Power supply system (can be changed only on EBOX plus with 230V power supply)**

If the power supply is 230V it is possible to specify whether it is single-phase (1 x 230V) or three-phase 230V (3 x 230V). The default is single-phase 230V. The correct setting is necessary if you want a correct indication of the output power (PO1 and PO2) and if you want to use the dry running protection by setting the dry running factor (parameter SO).

**RF: Reset fault & warning**

Holding down the + and – keys together for at least 2 seconds deletes the history of faults and warnings. The number of faults present in the log is indicated under the symbol RF (max 64). The log can be viewed from the MONITOR menu on page FF.

**PW: Setting the password**

The E.Box display has a password-protected system. If a password is set, the parameters will be accessible and visible but it will not be possible to change them.

When the password (PW) is "0" all the parameters are unlocked and can be edited.

When a password is used (value of PW different from 0) all modifications are blocked and "XXXX" is displayed on the page PW.

If the password is set it allows to navigate through all the pages, but at any attempt to edit a parameter a pop-up appears, asking you to type in the password. The pop-up allows you to quit or to type in the password and edit the parameter.

When the correct password is typed in the parameters are unlocked and can be edited for 10'.

When the correct password is typed in a padlock is shown opening, while if the wrong password is given a flashing padlock appears.

If the wrong password is typed in more than 10 times the same wrong password padlock appears with inverted colours and no password can be accepted until the appliance has been switched off and on again. After resetting the factory values the password is set back at "0".

Each change of the password takes effect when "Mode" or "Set" is pressed and each subsequent change of a parameter implies typing in the new password again (e.g. the installer makes all the settings with the default PW value = 0 and lastly, before leaving, he sets the PW so as to be sure that the machine is already protected without any further action).

If the password is lost there are 2 possibilities for editing the parameters of the E.Box:

- Make a note of all the parameter values, reset the e.box with the factory values. The reset operation deletes all the e.box parameters, including the password. See chapter RESET AND FACTORY SETTINGS
- Make a note of the number present on the password page, send a mail with this number to your service centre, in a few days you will be sent the password to unlock the E.Box.

**10 PANEL PROTECTIONS AND ALARMS**

If an error occurs, this is indicated by the E.box in several ways:

- The error leds light up on the main interface , the position of the led indicates whether it is an error of the panel or of a pump. The number of blinks indicates the type of error.
- Indication on the display (if present). As well as indicating the type of error, the models with a display indicated when the error occurred, and how many times. There is also an error log.
- Remote indication. The error signal can be sent by remote control to a siren, a telephone dial or other means. For this function there are the relays Q1, Q2 and Q3. For further information, see table 17.

**10.1 Errors indicated by alarm leds and relays**

This type of signal is always available with all models of E.Box and consists of:

- 3 error leds that indicate where the error occurred, on the overall system or on the pump P1 or P2.
- A number of blinks of these leds that indicates the type of error.

ENGLISH

- A remote signal on the relays: Q1 Q2 Q3. This signal can be used to turn on sirens and/or blinking or fixed lights. These contacts can also be sent to a telephone dial to obtain alarms via GSM. In general, Q1 indicates errors of the pump P1, Q2 those of the pump P2, and Q3 those of the system.

The table below indicates the following for each alarm, indicated by leds and relays:

- Brief description. More detailed descriptions are supplied in the following paragraphs.
- Alarm symbol.
- Number of blinks of the pump alarm leds.
- Number of blinks of the system alarm leds.
- If the alarm is self-resetting or if resetting must be done manually with the pump alarm reset or global reset buttons.
- If the alarm is blocking or if it still allows operation of the panel.
- Which relay contacts are closed in the presence of the alarm. In general, Q1 indicates errors of the pump P1, Q2 those of the pump P2, and Q3 those of the system.

Name of alarm/malfunction		Led signal on front board		Alarm property		Remote signal		
		P1 P2	System	automatic reset	blocking	Q1	Q2	Q3
Alarm relay/remote control switch			**	X	X	X	X	**
Pump disconnected			**	X	*	X	X	**
Dry operation alarm			**			X	X	X
Alarm too frequent starts			**	X		X	X	X
Current overload alarm			**	X	*	X	X	**
Alarm coming from R				X				X
Alarm coming from N				X (***)				X
Pressure/depth sensor alarm				X				X
Floats incoherence alarm				X				X
Dip-switch Incoherence alarm					X			X
Key error alarm								
Input voltage alarm				X	X			X

ENGLISH

Voltage selector error alarm					X			X
Voltage error alarm					X			X
Internal error alarm					X			X
General alarm pump P1+P2					X	X	X	X

Table 17: General table of alarms: signals and contacts



Indicates the number of blinks made by the warning led



Led lit with fixed light

\*

The alarm may occur up to a maximum of 6 times in 24 hours, after which it becomes blocking.

\*\*

If malfunctions/alarms occur on both pumps at the same time, the REMOTE ALARM (relays Q1, Q2, Q3) is activated and the GENERAL ALARM (red) is lit with a fixed light.

\*\*\*

In KIWA pressure boosting mode the error is not self-resetting and must be reset manually.

**Self-resetting alarm =**

The E.Box reactivates the pump if the cause that generated the alarm is removed, or, in cases where this is not possible, it makes attempts at intervals of time.

**Blocking alarm =**

The E.Box keeps the pump stopped until a manual reset is carried out.

10.2 Digital inputs R and N protection /alarm

Digital inputs	Pressure boosting and KIWA pressure boosting function	Filling function	Draining function
R	<p><b>Max. Pressure</b></p> <p>The 2 pumps stop with:</p> <ul style="list-style-type: none"> <li>- general alarm signal,</li> <li>- <b>Q3</b> remote signal</li> </ul>	<p><b>Min. Level (in tank)</b></p> <p>The 2 pumps start with:</p> <ul style="list-style-type: none"> <li>- general alarm signal,</li> <li>- <b>Q3</b> remote signal</li> </ul> <p>Tripping and reset after 0.5 seconds.</p>	<p><b>Max. level</b></p> <p>The 2 pumps start with:</p> <ul style="list-style-type: none"> <li>- general alarm signal,</li> <li>- <b>Q3</b> remote signal</li> </ul> <p>Tripping and reset after 0.5 seconds.</p>
N	<p><b>Min. Pressure</b></p> <p>The 2 pumps stop with:</p> <ul style="list-style-type: none"> <li>- general alarm signal,</li> <li>- alarm signal against dry running,</li> <li>- <b>Q3</b> remote signal</li> </ul>	<p><b>Max. level (in tank)</b></p> <p>The 2 pumps stop with:</p> <ul style="list-style-type: none"> <li>- general alarm signal,</li> <li>- <b>Q3</b> remote signal</li> </ul> <p><b>Min. Level (water reserve)</b></p> <p>The 2 pumps stop with:</p> <ul style="list-style-type: none"> <li>- general alarm signal,</li> <li>- signal against dry running,</li> <li>- <b>Q3</b> remote signal</li> </ul> <p>Tripping and reset after 1 second.</p>	<p><b>Min. Level</b></p> <p>The 2 pumps stop with:</p> <ul style="list-style-type: none"> <li>- general alarm signal,</li> <li>- alarm signal against dry running,</li> <li>- <b>Q3</b> remote signal</li> </ul> <p>Tripping and reset after 1 second.</p>
	Attention! if terminals R and N are not used they must be jumpered!	Attention! if terminal N is not used it must be jumpered! If level probes are used, only R must be jumpered, if it is not used.	Attention! if terminal N is not used it must be jumpered!

Table 18: Digital inputs R and N protection /alarm

**- Relay/remote control switch alarm**

This error appears if the pump remote control switches have malfunctions. If this alarm occurs, check the wiring. If defects are found, the panel must be repaired.

**- Pump disconnected**

This error appears if the E.Box panel does not "feel" current towards a pump. This error also appears if input KK (motor thermal protection) opens. The alarm is specific for the pump. For each pump the alarm allows a series of restart attempts with a variable pause time between one start and the next which is increased by 1 minute for the first 60 minutes (1-2-3 min.... 60 min.), after which there will be one attempt every hour.

To solve this error, check the pumps and the wiring and check the value of the set rated current (trimmer I<sub>max</sub>).

**- Dry running protection/alarm**

When the pressure falls to a value of less than 0.5 bar for about 10 seconds, the alarm is activated with stopping of the pump and lighting of the led. The dry running protection/alarm is activated in pressure boosting mode when an analog pressure sensor is connected.

This protection may be selected by the DS\_A4.

After 1 minute there will be 1 reset attempt for maximum 30 seconds. If this attempt succeeds the alarm is reset, otherwise the pump will remain in blocked status.



**The dry running protection/alarm is not activated if the electropumps are started manually.**

To solve the problem, check the hydraulic part of the plant. Check that everything is in order. Check also the pressure sensor and ensure the pressure reading is regular.

**- Protection against too frequent starts**

This error appears when the system needs more than 8 starts per pump per minute; this normally occurs when there are leaks in the system or the expansion vessel is deflated.

The protection against rapid starts allows each pump a maximum number of 8 starts per minute.

The protection does not intervene if the number of starts per minute is less than 8.

To solve the problem, check whether there are any leaks and check the expansion vessel if present.

**- Current overload protection/alarm (overload protection)**

This alarm appears in the event of a current overload on the pumps. The alarm is specific for the pump.

For each pump the current overload alarm allows 6 auto-reset attempts, every 10 minutes, in the space of 24 working hours. At the seventh attempt the panel no longer makes auto-resets, unless after manual reset by the user. To solve this problem, check the pumps, the wiring, and ensure the rated current of the pumps is set correctly. This error may be generated by a blocked pump.

**- Pressure or depth sensor alarm**

If operation with a sensor is selected, but the panel does not detect the sensor, the pumps are deactivated and an alarm is indicated. In this case check the wiring.

If the sensor has been correctly installed, but the sensor signal is outside the measuring range, the pumps are deactivated and an alarm is indicated. Check the pressure in the plant and, if the sensor reading is not correct, change the sensor.

**- Floats and/or probes incoherence alarm**

This error occurs when the state of the floats or of the level probes is not correct, for example the float on the highest level of the tank indicates the presence of water and the lower floats do not. To solve these problems, check the wiring and the state of the floats. It is possible to see the position detected by the panel on the display. It is recommended to check that there are no holes in the floats.

**- Dip-Switch alarm**

The Dip Switch alarm is activated in the following cases:

**Incoherence of the Dip Switch with the respective functions (incorrect configuration).**

To reset the alarm:

- Return the Dip Switches to the correct position.
- Press the RESET key.

**Dip Switch regulation with the panel live.**

To reset the alarm, press the RESET key.

**- Error alarm**

If pressing of the buttons on the front board is detected in the first 30 seconds of power supply, the buttons incoherence alarm is activated. Check that the buttons function efficiently!

**- Input voltage**

If the alternating input voltage of the panel is not within the limits established in the specifications, the alarm is given for irregular alternating input voltage. The alarm is deactivated one minute after the alternating input voltage returns within the limits. If this alarm occurs, check the panel input voltage. If it is regular, the panel must be replaced.

**- Voltage selector error**

This error may occur on the E.Box plus, in the case of a fault of the E.Box Plus or breakage of the fuse FU2. In the case of an alarm, check the fuse FU2 and ensure the panel is supplied with an adequate voltage, as specified in Table 1 – Technical Data.

**- Voltage Error**

If the electronic board has a fault that takes one of its internal voltages to unacceptable levels, the alarm is activated for panel internal voltage error. This error cannot be reset.

If this error appears, check the supply voltages and the wiring. If everything is in order, the E.Box has suffered internal damage and must be repaired.

**- Internal error**

Panel internal error. This error cannot be reset. If this error appears, check the supply voltages and the wiring. If everything is in order, the E.Box has suffered internal damage and must be repaired.

**- General pump error P1 + P2**

This error appears when no pump is available for pumping. To solve the problem, look at the pump errors.

**10.3 Alarms shown on the display**

If an alarm occurs, a page is shown on the display indicating:

- With an icon whether it is a system alarm or an pump P1 or P2 alarm.
- Code and brief description of the type of alarm.

The window with the alarm remains visible until a key is pressed or until the cause of the alarm disappears.

A complete indication of the alarms can be found in the alarm log.

**10.3.1 Alarms indicated on the display**

The table below indicates for each alarm:

- Brief description and code, corresponding to the one shown, possibly in abbreviated form, on the display. More detailed descriptions are supplied in the following paragraphs.
- If the alarm concerns the individual pump or the system.
- If the alarm is self-resetting or if it must be manually reset with the reset buttons.
- Which relay contacts are closed in the presence of the alarm. In general, Q1 indicates errors of the pump P1, Q2 those of the pump P2, and Q3 those of the system.

The alarms are also indicated by the alarm leds present on the front panel, but if there is a display it is preferable to refer to the indications given on the display, which contain more information.



Description	Code	Pump/System	Self-resetting alarm	Q1	Q2	Q3
Relay/remote control switch	<b>JR</b>	P	X	X	X	
Pump disconnected	<b>NC</b>	P	X	X	X	
Dry operation	<b>BL</b>	P/S	X	X	X	X
Too frequent starts	<b>LK</b>	P/S	X	X	X	X
Current overload	<b>OC</b>	P	X	X	X	
Pressure switch for maximum pressure	<b>RI</b>	S	X			X
Maximum level float						
Minimum level float						
Minimum level probe						
Maximum level probe	<b>NI</b>	S	X(**)			X
Pressure switch for minimum pressure						
Maximum level float						
Minimum level float						
Minimum level probe	<b>HL</b>	S	X			X
Maximum level						
Minimum level	<b>LL</b>	S	X			X
Pressure sensor	<b>BP1/BP2</b>	S	X			X
Depth sensor						
Float state incoherence	<b>FI</b>	S	X			X
Level probes state incoherence						
Dip switch	<b>DS</b>	S	X			X
Trimmer SP	<b>W1</b>	S	X			X
Trimmer DP	<b>W2</b>	S	X			X
Trimmer I <sub>max</sub>	<b>W3</b>	S	X			X
Key error	<b>PK</b>	S	X			X
Input voltage	<b>NL</b>	S	X			X
Voltage selector error	<b>VS</b>	S				X
Voltage error	<b>V0..V15</b>	S	X			X
Change operating mode	<b>OM</b>	S				
Internal error	<b>E0..E15</b>	S				X

Table 19: E.Box errors shown on the display

(\*) in pressure boosting mode (not KIWA) the alarm could be generated also by a float/level probe immersed in the pump from which the pumps are drawing.

(\*\*) in KIWA pressure boosting mode the alarm is not self-resetting and must be reset manually.

**- JR: Relay/remote control switch stuck alarm**

This error appears if the pump remote control switches have malfunctions. If this alarm occurs, check the wiring. If defects are found, the panel must be repaired.

**- NC: Pump Disconnected**

This error appears if the E.Box panel does not “feel” current towards a pump. This error also appears if input KK (motor thermal protection) opens.

The alarm is specific for the pump. For each pump the alarm allows a series of restart attempts with a variable pause time between one start and the next which is increased by 1 minute for the first 60 minutes (1-2-3 min.... 60 min.), after which there will be one attempt every hour.

**- BL: Dry running protection/alarm**

The dry running protection/alarm is activated in a pressure boosting situation when an analog pressure sensor is connected, while in other operating modes it is necessary to set the parameter SO at a value other than “OFF”.

This protection can be activated by setting the parameter TB at a value other than zero.

The protection intervenes:

- When the pressure falls to a value lower than the parameter MP (default 0.45bar) for a time equal to the parameter TB, the alarm is activated with stopping of the pump and lighting of the led.
- If the dry running factor for one of the pumps falls below this value during operation. For further information on the setting of SO, see paragraphs 9.4.4 and 9.4.5.

After 1 minute there will be 1 reset attempt for maximum 30 seconds. If this attempt succeeds the alarm is reset, otherwise the pump will remain in blocked status.



**The dry running protection/alarm is not activated if the electropumps are started manually.**

To solve the problem, check the hydraulic part of the plant. Check that everything is in order. Check also the pressure sensor and ensure the pressure reading is regular.

**- LK: Protection against too frequent starts**

This error appears when the system needs more than 8 starts per pump per minute; this normally occurs when there are leaks in the system or the expansion vessel is deflated.

The protection against rapid starts allows each pump a maximum number of 8 starts per minute.

The protection does not intervene if the number of starts per minute is less than 8.

To solve the problem, check whether there are any leaks and check the expansion vessel if present.

**- OC: Current overload protection/alarm (overload protection)**

This alarm appears in the event of a current overload on the pumps. The alarm is specific for the pump.

For each pump the current overload alarm allows 6 auto-reset attempts, every 10 minutes, in the space of 24 working hours. At the seventh attempt the panel no longer makes auto-resets, unless after manual reset by the user. To solve this problem, check the pumps, the wiring, and ensure the rated current of the pumps is set correctly. This error may be generated by a blocked pump.

**- RI: RI alarms**

These errors come from input R. The panel behaviour is different depending on the operating mode. The solution of the problem always consists of checking the signal arriving from the input R.

Message	Meaning and description
Pressure switch for maximum pressure	This error appears in pressure boosting and indicates that the maximum pressure switch is activated or that the contact R has not been jumpered. The E.Box stops the pumps.
Maximum level float	This error appears in drainage and indicates that the maximum level float is activated or that the contact R has been jumpered. The E.Box activates the pumps.
Minimum level float	This error appears in filling and indicates that the minimum level float is activated or that the contact R has been jumpered. The E.Box activates the pumps.
Minimum level probe	This error appears in filling and indicates that the level probe for minimum level is activated or that the contact R has not been jumpered. The E.Box activates the pumps.
Maximum level probe	This error appears in drainage and indicates that the level probe for maximum level is activated or that the contact R has been jumpered. The E.Box activates the pumps.

Table 20: RI alarms

**- NI: NI alarms**

These errors come from input N. The panel behaviour is different depending on the operating mode. The solution of the problem always consists of checking the signal arriving from the input N.

Message	Meaning and description
Pressure switch for minimum pressure	This error appears in pressure boosting and indicates that the maximum pressure switch is activated or that the contact N has not been jumpered. The E.Box stops. In KIWA pressure boosting the error is not self-resetting and manual intervention is necessary.
Maximum level float	This error appears in filling and indicates that the minimum level float is activated or that the contact N has not been jumpered. The E.Box stops the pumps.
Minimum level float	This error appears in drainage and indicates that the minimum level float is activated or that the contact N has not been jumpered. The E.Box stops the pumps.
Minimum level probe	This error appears in drainage and indicates that the level probe for minimum level is activated or that the contact N has not been jumpered. The E.Box stops the pumps.
Maximum level probe	This error appears in filling and indicates that the level probe for maximum level is activated or that the contact N has been jumpered. The E.Box activates the pumps.

Table 21: NI alarms

**- HL: Maximum level alarm**

This error comes from the depth sensor, when its indication exceeds the threshold ML (Maximum Level). This can happen when the depth sensor is used for the maximum and minimum level alarms. The solution of the problem always consists of checking the set thresholds, the level of liquid in the tank and the sensor status. The panel behaviour is different depending on the operative mode. In drainage this error causes the forced start of the pumps and in filling the forced stop of the pumps.

**- LL: Minimum level alarm**

This error comes from the depth sensor, when its indication is below the threshold LOL (Minimum Level). This can happen when the depth sensor is used for the maximum and minimum level alarms. The solution of the problem always consists of checking the set thresholds, the level of liquid in the tank and the sensor status. The panel behaviour is different depending on the operative mode. In filling this error causes the forced start of the pumps and in drainage the forced stop of the pumps.

**- BP1/BP2: Pressure sensor / depth sensor alarm**

If operation with a pressure or depth sensor is selected, but the panel does not detect the sensor, the pumps are deactivated and an alarm is indicated. In this case check the wiring.

If the sensor has been correctly installed, but the sensor signal is outside the measuring range, the pumps are deactivated and an alarm is indicated. Check the pressure in the plant and, if the sensor reading is not correct, change the sensor.

**- FI: Floats or level probes state incoherence**

This error occurs when the state of the floats or of the level probes is not correct, for example the float on the highest level of the tank indicates the presence of water and the lower floats do not. To solve these problems, check the wiring and the state of the floats. It is possible to see the position detected by the panel on the display. It is recommended to check that there are no holes in the floats.

**- DS: Dip Switch alarm**

The Dip Switch alarm appears if the positions of the dip switches have been changed.

If the new configuration of the dip switches is valid, you are asked whether to accept it or ignore it. If it is accepted, the E.Box will start to work with the new configuration. If the new configuration is not valid, it is proposed that you ignore it.

**- W1: Trimmer SP**

This error appears if the trimmer SP inside the panel has been moved. You are asked whether to accept or ignore the new value of SP. If it is accepted, the value of the dip switches will also be accepted.

**- W2: Trimmer DP**

This error appears if the trimmer DP inside the panel has been moved. You are asked whether to accept or ignore the new value of DP. If it is accepted, the value of the dip switches will also be accepted.

**- W3: Trimmer I<sub>max</sub>**

This error appears if the trimmer I<sub>max</sub> inside the panel has been moved. You are asked whether to accept or ignore the new value of I<sub>max</sub>. If it is accepted, the value of the dip switches will also be accepted.

**- PK: Key error**

If pressing of the buttons on the front board is detected in the first 30 seconds of power supply, the buttons incoherence alarm is activated. Check that the buttons function efficiently!

**- NL: Input voltage error**

If the alternating input voltage of the panel is not within the limits established in the specifications, the input voltage alarm is given. The alarm is deactivated one minute after the alternating input voltage returns within the limits. If this error appears, check that the supply voltage is within the limits accepted by the E.Box panel, see table 1 - Technical Data.

**- VS: Voltage selector error**

This error may occur on the E.Box plus, in the case of a fault of the E.Box Plus or breakage of the fuse FU2. In the case of an alarm, check the fuse FU2 and ensure the panel is supplied with an adequate voltage, as specified in Table 1 – Technical Data.

**- V0..V15: Voltage error**

If the electronic board has a fault that takes one of its internal voltages to unacceptable levels, the alarm is activated for panel internal voltage error V0..V15. This error cannot be reset. The code Vx indicates the part of the circuit where the malfunction was found. If this error appears, check the supply voltages and the wiring. If everything is in order, the E.Box has suffered internal damage and must be repaired.

**- OM: Changed operating mode**

This message is only a warning and is not an error. It appears only in the alarm log and indicates that the configuration of the E.Box has been changed, for example from drainage to pressure boosting.

**- E0..E15: Internal error**

Panel internal error. This error cannot be reset. If this error appears, check the supply voltages and the wiring. If everything is in order, the E.Box has suffered internal damage and must be repaired.

**11 RESET AND FACTORY SETTINGS**

**11.1 General system reset**

To reset the E.Box, switch the panel off and on again. The operation does not delete the settings saved by the user.

**11.2 Restoring the factory settings**

To restore the factory values, switch off the E.box, wait until the display has switched off completely, press and hold down the "SET" and "+" keys and turn on the power; release the two keys only when the letters "EE" appear.

After this procedure the configuration wizard starts.

If the display is not present, it is sufficient to change the DIP SWITCH configuration to E.Box not supplied and supply the E.Box again.