

---

**ISTRUZIONI PER L'INSTALLAZIONE E LA MANUTENZIONE**  
**INSTRUCTIONS POUR L'INSTALLATION ET LA MAINTENANCE**  
**INSTRUCTIONS FOR INSTALLATION AND MAINTENANCE**  
**INSTALLATIONS- UND WARTUNGSANLEITUNGEN**  
**INSTRUCTIES VOOR INSTALLATIE EN ONDERHOUD**  
**INSTRUCCIONES DE INSTALACIÓN Y MANTENIMIENTO**  
**INSTALLATIONS- OCH UNDERHÅLLSANVISNING**  
**РУКОВОДСТВО ПО МОНТАЖУ И ТЕХНИЧЕСКОМУ ОБСЛУЖИВАНИЮ**  
**KURMA VE BAKIM BİLGİLERİ**  
**ΟΔΗΓΙΕΣ ΓΙΑ ΤΗΝ ΕΓΚΑΤΑΣΤΑΣΗ ΚΑΙ ΤΗ ΣΥΝΤΗΡΗΣΗ**  
**INSTRUCTIUNI PENTRU INSTALARE SI INTRETINERE**  
**NAVODILA ZA VGRADNJO IN UPORABO**  
**ИНСТРУКЦИЯ ЗА МОНТАЖ И ПОДДРЪЖКА**  
**INSTALLÁCIÓS ÉS KARBANTARTÁSI UTASÍTÁS**

**MCE-22/C**  
**MCE-15/C**  
**MCE-11/C**  
**V7.0**

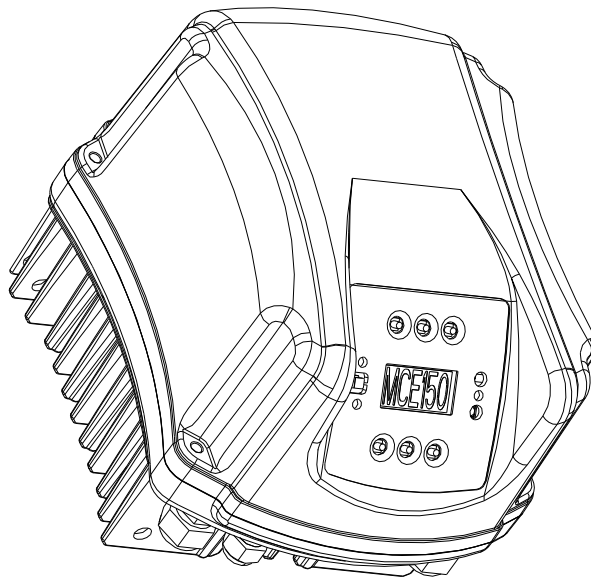

<b>ITALIANO</b>	<b>pag.</b>	<b>01</b>
<b>FRANÇAIS</b>	<b>page</b>	<b>17</b>
<b>ENGLISH</b>	<b>page</b>	<b>33</b>
<b>DEUTSCH</b>	<b>seite</b>	<b>49</b>
<b>NEDERLANDS</b>	<b>pag.</b>	<b>65</b>
<b>ESPAÑOL</b>	<b>pág.</b>	<b>81</b>
<b>SVENSKA</b>	<b>sid.</b>	<b>97</b>
<b>РУССКИЙ</b>	<b>стр.</b>	<b>113</b>
<b>TÜRKÇE</b>	<b>sf.</b>	<b>129</b>
<b>ΕΛΛΗΝΙΚΑ</b>	<b>σελ.</b>	<b>145</b>
<b>ROMANA</b>	<b>pag.</b>	<b>161</b>
<b>SLOVENŠČINA</b>	<b>Stran</b>	<b>177</b>
<b>БЪЛГАРСКИ</b>	<b>Стр.</b>	<b>193</b>
<b>MAGYAR</b>	<b>Old.</b>	<b>209</b>

INDEX

1. KEY.....	33
2. GENERAL .....	33
2.1 Safety .....	34
2.2 Responsibility.....	34
2.3 Particular warnings.....	34
3. APPLICATIONS .....	34
4. TECHNICAL DATA .....	34
4.1 Electromagnetic Compatibility (EMC).....	35
5. ELECTRICAL CONNECTIONS.....	35
5.1 Connection to the Power Supply Line .....	35
5.2 Connection to the Electropump.....	35
5.3 Earth Connection .....	36
5.4 Connection of the Differential Pressure Sensor .....	36
5.5 Electrical Connections of Inputs and Outputs .....	37
5.5.1 Digital Inputs .....	37
5.5.2 Analogue input 0-10V .....	39
5.5.3 NTC wiring diagram for measuring the fluid temperature (T and T1) .....	39
5.5.4 Outputs .....	40
5.6 Connection for Twin Systems.....	41
6. START .....	41
7. FUNCTIONS.....	41
7.1 Regulating Modes .....	41
7.1.1 Regulation with Constant Differential Pressure .....	42
7.1.2 Regulation with Constant Curve .....	42
7.1.3 Regulation with Constant Curve with External Analogue Signal .....	42
7.1.4 Regulation with Proportional Differential Pressure .....	42
7.1.5 T constant function .....	42
7.1.6 $\Delta T$ -constant function .....	43
7.2 Quick Start function.....	43
8. CONTROL PANEL .....	43
8.1 Graphic Display.....	44
8.2 Navigation Buttons .....	44
8.3 Warning Lights .....	44
9. MENU .....	44
10. FACTORY SETTINGS.....	48
11. TYPES OF ALARM .....	48
12. MODBUS MCE-C .....	48
13. BACNET.....	48

1. KEY

The frontispiece shows the version of this document in the form **Vn.x**. This version indicates that the document is valid for all software versions of the device **n.y**. For example: V3.0 is valid for all Sw: 3.y.

In this document the following symbols will be used to avoid situations of danger.



Situation of **general danger**. Failure to respect the instructions that follow may cause harm to persons and property.



Situation of **electric shock hazard**. Failure to respect the instructions that follow may cause a situation of grave risk for personal safety.

2. GENERAL



**Read this documentation carefully before installation.**

Installation, electrical connection and commissioning must be carried out by specialised personnel, in compliance with the general and local safety regulations in force in the country in which the product is installed. Failure to respect these instructions not only causes risk to personal safety and damage to the equipment, but invalidates every right to assistance under guarantee.



**Ensure that the product has not suffered any damage during transport or storage. Check that the outer casing is unbroken and in excellent conditions.**

**2.1 Safety**

The device contains an electronic device with inverter.

Use is allowed only if the electric system is in possession of safety precautions in accordance with the regulations in force in the country where the product is installed (for Italy CEI 64/2). The appliance is not intended to be used by persons (including children) with reduced physical, sensory or mental capacities, or who lack experience or knowledge, unless, through the mediation of a person responsible for their safety, they have had the benefit of supervision or of instructions on the use of the appliance. Children must be supervised to ensure that they do not play with the appliance.

**2.2 Responsibility**

The Manufacturer does not vouch for correct operation of the machine or for any damage that it may cause if it has been tampered with, modified and/or run outside the recommended work range or in contrast with other indications given in this manual.

**2.3 Particular warnings**



Always switch off the mains power supply before working on the electrical or mechanical part of the system. Before opening the equipment, wait at least 5 minutes after disconnecting it from the power supply. The capacitor of the direct current intermediate circuit remains charged with dangerously high voltage even after the mains power has been turned off.

**Only firmly cabled mains connections are admissible. The appliance must be earthed (IEC 536 class 1, NEC and other applicable standards).**



**Mains terminals and motor terminals may still have dangerous voltage when the motor is stopped.**

**3. APPLICATIONS**

The inverter of the **MCE/C** series is a device conceived for the management of **circulation pumps** allowing integrated regulation of the differential pressure (head); it is thus possible to adapt the performance of the circulation pump to the actual demands of the system.

This determines considerable energy saving, a greater possibility of control of the system, and reduced noise.

**The MCE-22/C inverter is designed so that it can be housed directly on the pump motor body.**

**4. TECHNICAL DATA**

		<b>MCE-22/C</b>	<b>MCE-15/C</b>	<b>MCE-11/C</b>
<b>Inverter power supply</b>	Voltage [VAC] (Tol. +10/-20%)	220-240	220-240	220-240
	Phases	1	1	1
	Frequency [zH]	50/60	50/60	50/60
	Current [A]	22,0	18,7	12,0
	Leakage current to earth [mA]	< 2		
<b>Inverter output</b>	Voltage [VAC] (Tol. +10/-20%)	0 - V supply	0 - V supply	0 - V supply
	Phases	3	3	3
	Frequency [Hz]	0-200	0-200	0-200
	Current [A rms]	10,5	8,0	6,5
	Mechanical power P2	3 HP / 2.2 kW	2 HP / 1.5 kW	1.5 HP / 1.1 kW
<b>Mechanical specifications</b>	Unit weight [kg] (excluding packaging)	5		
	Maximum dimensions [mm] (WxHxD)	200x199x262		
<b>Installation</b>	Work position	Housed on pump motor casing		
	IP protection rating	55		
	Max. ambient temperature [°C]	40		
<b>Control and operating hydraulic specifications</b>	Differential pressure regulation range	1-95% pressure sensor full scale		
<b>Sensors</b>	Type of pressure sensors	Ratiometric		
	Differential pressure sensor full scale [bar]	4/10		
<b>Functions and protections</b>	Connectivity	<ul style="list-style-type: none"> <li>• Multi inverter connection</li> </ul>		
	Protections	<ul style="list-style-type: none"> <li>• Self-protected against current overload</li> <li>• Temperature overload on internal electronics</li> <li>• Abnormal power supply voltages</li> <li>• Direct short-circuit between the output phases</li> </ul>		
<b>Temperatures</b>	Storage temperature [°C]	-10 ÷ 40		

Table 1: Technical data

#### 4.1 Electromagnetic Compatibility (EMC)

MCE/C inverters respect standard EN 61800-3, in the C2 category, for electromagnetic compatibility.

- Electromagnetic emissions. Residential environment (in some cases restrictive measures may be requested).
- Conducted emissions. Residential environment (in some cases restrictive measures may be requested).

#### 5. ELECTRICAL CONNECTIONS



Always switch off the mains power supply before working on the electrical or mechanical part of the system. Before opening the equipment, wait at least 5 minutes after disconnecting it from the power supply. The capacitor of the direct current intermediate circuit remains charged with dangerously high voltage even after the mains power has been turned off.

**Only firmly cabled mains connections are admissible. The appliance must be earthed (IEC 536 class 1, NEC and other applicable standards).**



**Ensure that the voltage and frequency on the data plate of the MCE-22/C are the same as those of the power mains.**

#### 5.1 Connection to the Power Supply Line

The connection between the single-phase power supply line and the MCE-22/C must be made with a 3-core cable (phase + neutral + earth). The characteristics of the power supply must satisfy the indications in *Table 1*.

The **input terminals** are the ones marked with the words **LINE LN** and with an **arrow entering** the terminals, see *Figure 1*.

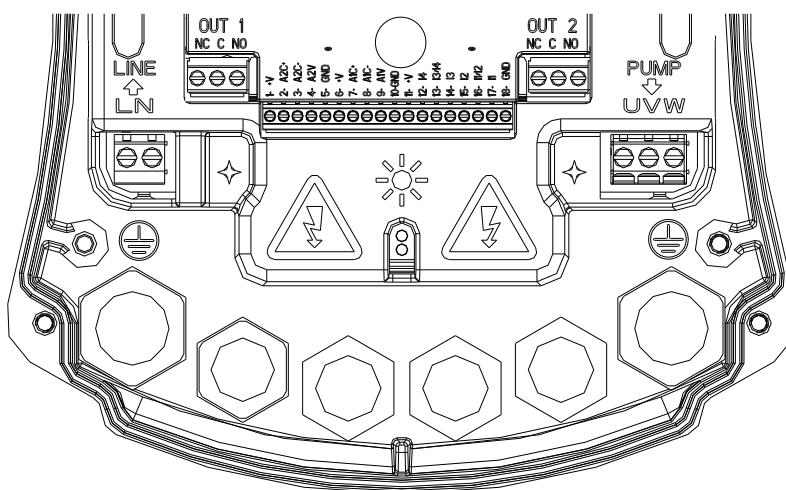

Figure 1: Electrical connections

The minimum section of the input and output cables must be such as to guarantee correct tightening of the cable clamps, while the maximum section accepted by the terminals is 4mm<sup>2</sup>.

The section, type and laying of the cables for supplying power to the inverter and connecting to the electropump must be chosen according to the regulations in force. The table 2 supplies an indication on the section of the cable to be used to supply power to the inverter. The table refers to 3-core PVC cables (phase + neutral + earth) and gives the recommended minimum section with relation to the current and the length of the cable.

The electropump current is generally specified on the motor data plate.

The maximum supply current of the MCE-22/C may generally be estimated as double the maximum current absorbed by the pump. Although the MCE-22/C has its own internal protections, it is still advisable to install a suitably sized thermal magnetic circuit breaker.

**ATTENTION:** The thermal magnetic circuit breaker and the power cables of the MCE-22/C and of the pump must be of a size suited to the system; if the indications given in the manual do not agree with the regulation in force, use the regulation as reference.

#### 5.2 Connection to the Electropump

The connection between the MCE-22/C and the electropump is made with a 4-core cable (3 phases + earth).

At output an electropump must be connected to a three-phase power supply with the characteristics specified in *Table 1*.

The output terminals are the ones marked with the words **PUMP UVW** and with an **arrow leaving** the terminals, see *Figure 1*.

The rated voltage of the electropump must be the same as the MCE-22/C power supply voltage.

The utility connected to the MCE-22/C must not absorb a current higher than the maximum that can be supplied, indicated in *Table 1*.

Check the data plates and the type of connection (star or delta) of the motor used to respect the above-mentioned conditions.

*Table 3* supplies an indication on the section of the cable to be used to connect to the pump. The table refers to 4-core PVC cables (3 phases + earth) and gives the recommended minimum section with relation to the current and the length of the cable.



The incorrect connection of the earth lines to a terminal other than the earth terminal may cause irreparable damage to the whole equipment.

The incorrect connection of the power supply line to the output terminals intended for the load may cause irreparable damage to the whole equipment.

**5.3 Earth Connection**

The earth connection must be made with cable lugs tightened as shown in *Figure 2*.

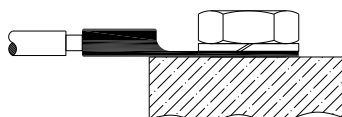

*Figure 2: Earth connection*

Cable section in mm <sup>2</sup>															
	10 m	20 m	30 m	40 m	50 m	60 m	70 m	80 m	90 m	100 m	120 m	140 m	160 m	180 m	200 m
4 A	1,5	1,5	1,5	1,5	2,5	2,5	2,5	2,5	2,5	4	4	4	6	6	6
8 A	1,5	1,5	2,5	2,5	4	4	6	6	6	6	10	10	10	10	16
12 A	1,5	2,5	4	4	6	6	10	10	10	10	10	16	16	16	-
16 A	2,5	2,5	4	6	10	10	10	10	10	16	16	16	-	-	-
20 A	4	4	6	10	10	10	16	16	16	16	16	-	-	-	-
24 A	4	4	6	10	10	16	16	16	16	-	-	-	-	-	-

Table valid for 3-core PVC cables (phase + neutral + earth) @ 230V.

*Table 2: Section of the inverter power supply cables*

Cable section in mm <sup>2</sup>															
	10 m	20 m	30 m	40 m	50 m	60 m	70 m	80 m	90 m	100 m	120 m	140 m	160 m	180 m	200 m
4 A	1,5	1,5	1,5	1,5	2,5	2,5	2,5	2,5	4	4	4	6	6	6	10
8 A	1,5	1,5	2,5	2,5	4	4	6	6	6	10	10	10	10	16	16
12 A	1,5	2,5	4	4	6	6	10	10	10	10	16	16	16	16	16
16 A	2,5	2,5	4	6	10	10	10	10	16	16	16	16	16	16	16
20 A	2,5	4	6	10	10	10	16	16	16	16	16	16	16	16	16
24 A	4	4	6	10	10	16	16	16	16	16	16	16	16	16	16
28 A	6	6	10	10	16	16	16	16	16	16	16	16	16	16	16
32 A	6	6	10	10	16	16	16	16	16	16	16	16	16	16	16

Table valid for 4-core PVC cables (3 phases + earth) @ 230V.

*Table 3: Section of the pump power supply cables*

**5.4 Connection of the Differential Pressure Sensor**

The MCE-22/C accepts two types of differential pressure sensor: ratiometric with full scale value **4 bar** or ratiometric with full scale value **10 bar**. The cable must be connected at one end to the sensor and at the other to the pressure sensor input provided on the inverter, marked "**Press 1**" (see *Figure 3*)

The cable has two different ends with obligatory direction of connection: connector for industrial applications (DIN 43650) on the sensor side and 4-pole connector on the MCE-22/C side.

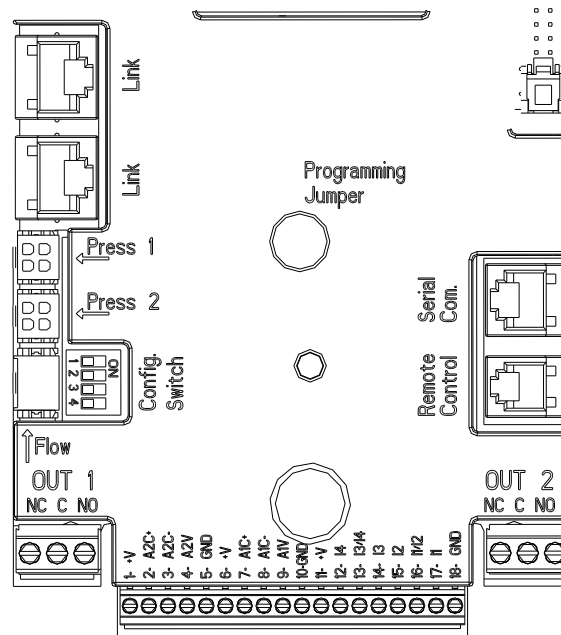

Figure 3: Connections

**5.5 Electrical Connections of Inputs and Outputs**

The MCE-22/C has 3 digital inputs, 2 NTC inputs for fluid temperature measurement T and T1 an analogue input and 2 digital outputs so as to be able to make certain interfaces with more complex installations.

Shown in Figure 4, Figure 5 and Figure 6 for example, are some possible configurations of the inputs and outputs.

For the installer it will be sufficient to wire up the desired input and output contacts and to configure their functions as desired (see par. 5.5.1 par. 5.5.2 and par. 5.5.4)

**5.5.1 Digital Inputs**

The digital inputs are screen-printed at the base of the 18-pole terminal board:

- I1: Terminals 16 and 17
- I2: Terminals 15 and 16
- I3: Terminals 13 and 14
- I4: Terminals 12 and 13

The inputs may be powered with either direct or alternating current. Shown below are the electrical characteristics of the inputs (see Table 4)

Electrical characteristics of the inputs		
	DC inputs [V]	AC inputs [Vrms]
Minimum switch-on voltage [V]	8	6
Maximum switch-off voltage [V]	2	1.5
Maximum admissible voltage [V]	36	36
Current absorbed at 12V [mA]	3.3	3.3
Max. accepted cable section [mm <sup>2</sup> ]	2.13	
<i>N.B. The inputs can be controlled with any polarity (positive or negative with respect to their earth connection)</i>		

Table 4: Electrical characteristics of the inputs

The example proposed in Figure 4 refers to the connection with a dry contact using the internal voltage to control the inputs.

**ATTENTION:** The voltage supplied between terminals 11 and 18 of J5 (18-pole terminal board) is **19 Vdc** and may distribute maximum **50 mA**.

If you have a voltage instead of a contact, it can still be used to control the inputs: it will be sufficient **not** to use the terminals +V and GND and to connect the source of voltage to the desired input, respecting the characteristics described in Table 4.



**ATTENTION: The pairs of inputs I1/I2 and I3/I4 have one pole in common for each pair.**

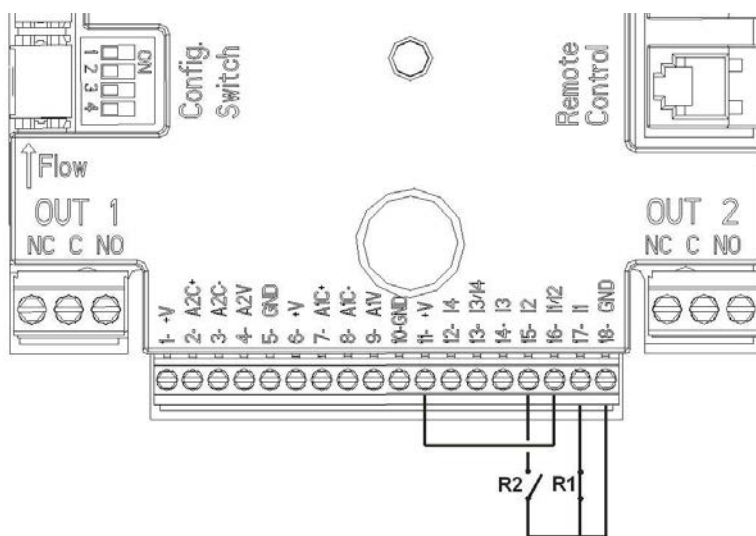

Figure 4: Example of Connection of Digital Inputs Start/Stop and Economy

Functions associated with the digital inputs	
I1	<b>Start/Stop:</b> If input 1 is activated from the control panel (see par. 9) it will be possible to command the switching on and off of the pump in remote mode.
I2	<b>Economy:</b> If input 2 is activated from the control panel (see par. 9) it will be possible to active the set-point reduction function in remote mode.
I3	<b>Quick Start:</b> If input 3 is activated from the control panel, the pump is started at the quick start frequency $F_q$ (see advanced menu).
I4	<b>Not enabled</b>

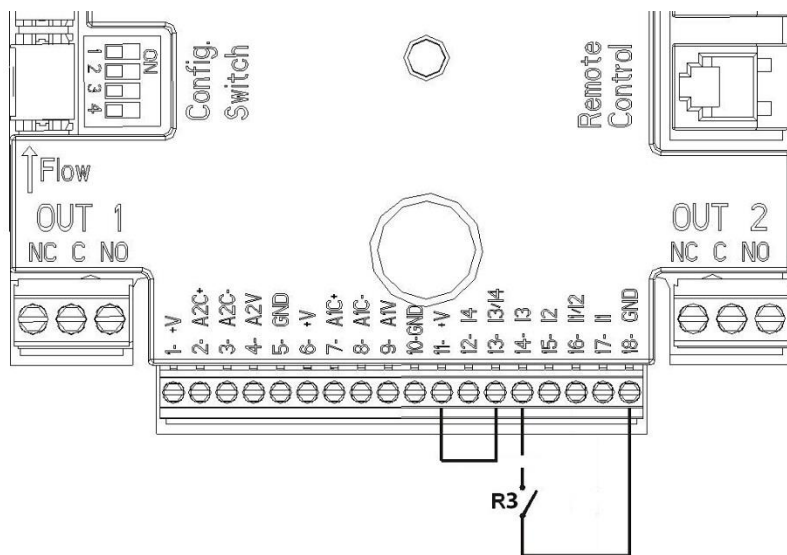

Figure 5: Example of Connection of Quick Start Digital Input

With reference to the example in Figure 4, and if the **EXT** and **Economy** functions have been activated from the control panel, the system behaviour will be as follows:

R1	R2	System Status
Open	Open	Pump stopped
Open	Closed	Pump stopped
Closed	Open	Pump running with set-point set by the user
Closed	Closed	Pump running with reduced set-point



### 5.5.2 Analogue input 0-10V

The analogue input 0-10V is screen-printed at the base of the 18-pole terminal board:

- **A1V** (terminal 9): Positive pole
- **GND** (terminal 10): Negative pole
- **A2V** (terminal 4): Positive pole
- **GND** (terminal 5): Negative pole

The function associated with the analogue input 0-10V is that of **regulating the pump rotation speed in proportion to the input voltage 0-10V itself** (see par. 0 and par. 9). The input A2V is not enabled.

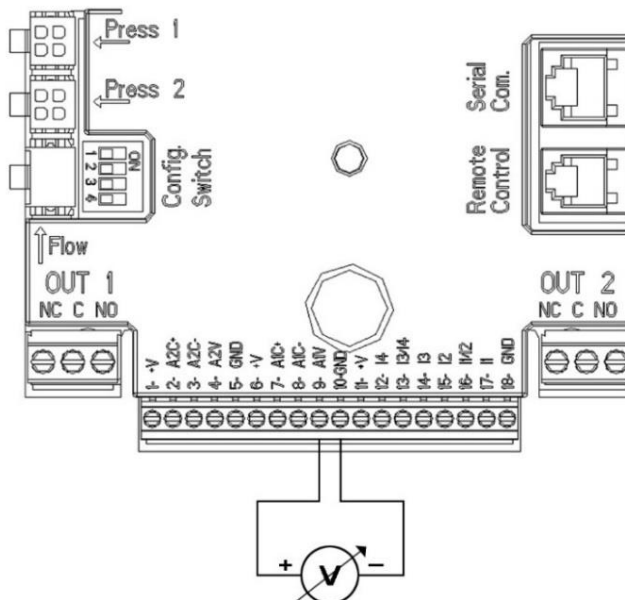

Figure 6: Example of Connection of Analogue Input

N.B: The 0-10V analogue input is mutually exclusive with the NTC type temperature sensor T connected to the same poles of the 18-pole terminal block.

### 5.5.3 NTC wiring diagram for measuring the fluid temperature (T and T1)

For installation of the fluid temperature sensors T and T1, refer to the following wiring diagrams, see figure 7 and figure 8.

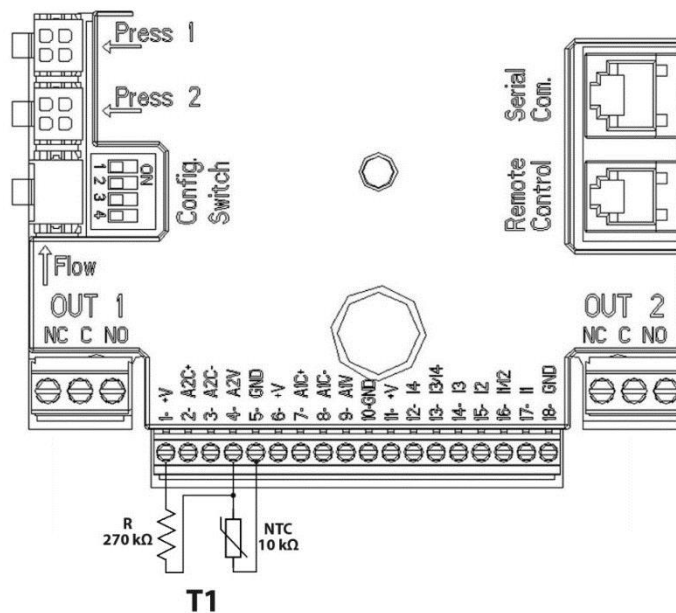

Figure 7: Connection of NTC sensor for temperature measurement T1

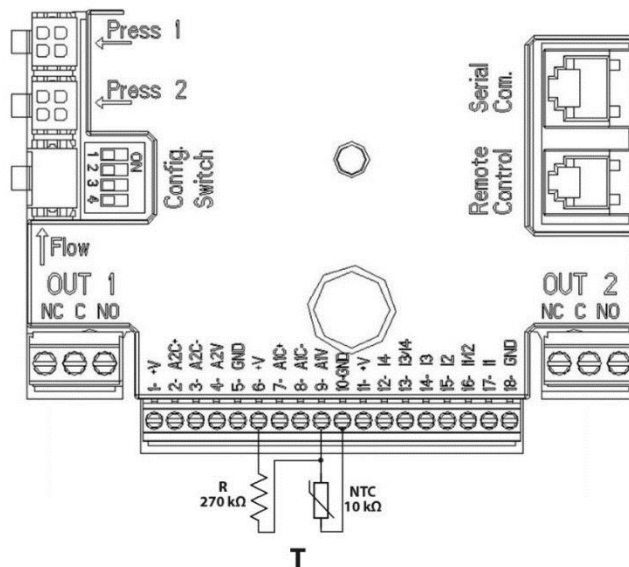

Figure 8: Connection of NTC sensor for temperature measurement T

N.B. Temperature reading via sensor T is only enabled in the following control modes: T constant increasing  $\begin{matrix} \uparrow T \uparrow \\ \longrightarrow \end{matrix}$  /decreasing  $\begin{matrix} \uparrow T \downarrow \\ \longrightarrow \end{matrix}$  and  $\Delta T$  constant  $\begin{matrix} \uparrow \Delta T \\ \longrightarrow \end{matrix}$ .

N.B. Temperature reading via sensor T1 is only enabled in the following control modes: T1 constant increasing  $\begin{matrix} \uparrow T1 \uparrow \\ \longrightarrow \end{matrix}$  /decreasing  $\begin{matrix} \uparrow T1 \downarrow \\ \longrightarrow \end{matrix}$  and  $\Delta T$  constant  $\begin{matrix} \uparrow \Delta T \\ \longrightarrow \end{matrix}$ .

For operating modes T constant and  $\Delta T$  constant see paragraphs 7.1.5 and 7.1.6

N.B: The input of temperature sensor T type NTC is mutually exclusive with the 0-10V analogue input connected to the same poles of the 18-pole terminal block.

### 5.5.4 Outputs

The connections of the outputs listed below refer to the two 3-pole terminal boards J3 and J4 indicated with the screen-printing **OUT1** and **OUT2** below which is also indicated the type of contact for the terminal (**NC** = Normally Closed, **C** = Common, **NO** = Normally Open).

Characteristics of the output contacts	
Type of contact	NO, NC, COM
Max. bearable voltage [V]	250
Max. bearable current [A]	5 If resistive load 2.5 If inductive load
Max. accepted cable section [mm <sup>2</sup> ]	3.80

Table 5: Characteristics of the output contacts

Functions associated with the outputs	
<b>OUT1</b>	Presence/Absence of alarms in the system
<b>OUT2</b>	Pump running/Pump stopped

In the example shown in *Figure 9* the light **L1** is lit when there is an alarm in the system and it goes off when no kind of malfunction is found, whereas the light **L2** is lit when the pump is running and goes off when the pump is stopped.

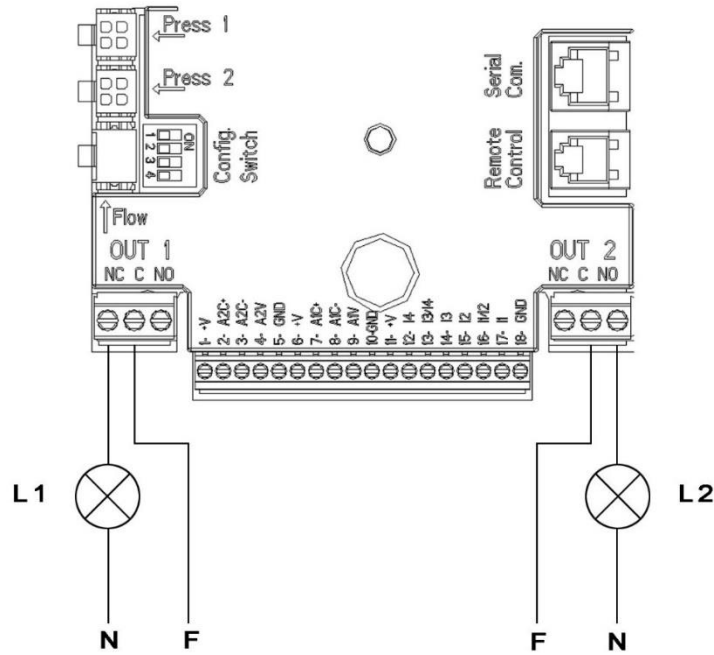

Figure 9: Example of Connection of Digital Outputs

**5.6 Connection for Twin Systems**

To make a twin system it is sufficient to connect the 2 inverters MCE-22/C using the cable supplied, fitting it onto both inverters in one of the 2 connectors indicated by the word **Link** (see Figure 3).

For correct operation of the twin system, all the external connections of the input terminal board, except for input 3 which can be managed independently, must be connected in parallel between the 2 MCE-22/C respecting the numbering of the individual terminals (for example, terminal 17 of MCE-22/C -1 to terminal 17 of MCE-22/C -2 and so on).



If at the time of changing over between switching off one motor and switching on the other you hear a knocking noise, proceed as follows:

- 1) hold down the central “menu” key for 5 seconds;
- 2) scroll through the parameters until you see ET;
- 3) increase the value of the ET parameter in the advanced menu until the noise disappears

For the possible operating modes of twin systems see par. 9.

**6. START**



**All the starting operations must be performed with the MCE-22/C cover closed.  
Start the system only when all the electrical and hydraulic connections have been completed.**

Once the system has been started it is possible to modify the operating modes to adapt better to the plant requirements (see par. 9).

**7. FUNCTIONS**

**7.1 Regulating Modes**

MCE-22/C systems allow use of the following regulating modes:

- Regulation with constant differential pressure (factory setting).
- Regulation with constant curve.
- Regulation with constant curve with speed set by external analogue signal.
- Proportional differential pressure regulation depending on the flow present in the plant.
- T constant regulation
- ΔT constant regulation

**7.1.1 Regulation with Constant Differential Pressure**

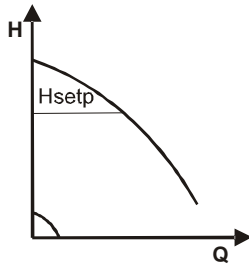

The head remains constant, irrespective of the water request.  
This mode may be set by means of the control panel on the cover of the MCE-22/C (see par. 9).

**7.1.2 Regulation with Constant Curve**

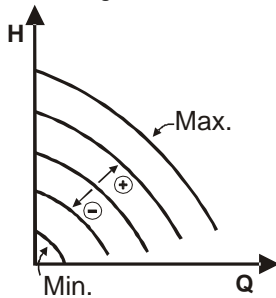

The rotation speed is kept at a constant number of revolutions. This rotation speed may be set between a minimum value and the rated frequency of the circulation pump (e.g. between 15 Hz and 50 Hz).  
This mode may be set by means of the control panel on the cover of the MCE-22/C (see par. 9).

**7.1.3 Regulation with Constant Curve with External Analogue Signal**

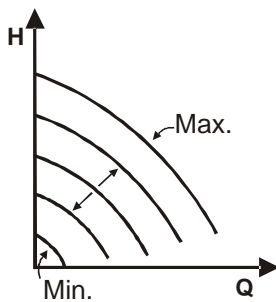

The rotation speed is kept at a constant number of revolutions in proportion to the voltage of the external analogue signal (see par. 5.5.2). The rotation speed varies in linear mode between the rated frequency of the pump when  $V_{in} = 10V$  and the minimum frequency when  $V_{in} = 0V$ .  
This mode may be set by means of the control panel on the cover of the MCE-22/C (see par. 9).

**7.1.4 Regulation with Proportional Differential Pressure**

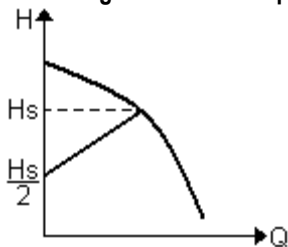

In this adjustment mode the differential pressure is reduced or increased as the water request falls or rises.  
This mode may be set by means of the control panel on the cover of the MCE-22/C (see par. 9).

**7.1.5 T constant function**

This function causes the circulator to increase or decrease the flow rate to keep constant the temperature measured by the NTC sensor, connected as described in paragraph 5.5.3.

Four operating modes can be set:

T Regulation:

Increasing mode T → if the desired temperature ( $T_s$ ) is higher than the measured temperature ( $T$ ), the circulator increases the flow rate until  $T_s$  is reached

Decreasing mode T → if the desired temperature ( $T_s$ ) is higher than the measured temperature ( $T$ ), the circulator decreases the flow rate until  $T_s$  is reached

T1 Regulation:

Increasing mode T1 → if the desired temperature ( $T_s$ ) is higher than the measured temperature ( $T_1$ ), the circulator increases the flow rate until  $T_s$  is reached

Decreasing mode T1 → if the desired temperature ( $T_s$ ) is higher than the measured temperature ( $T_1$ ), the circulator decreases the flow rate until  $T_s$  is reached

**7.1.6 ΔT-costant function**

This feature allows the circulator to increase or decrease the flow rate to keep the temperature difference T-T1 constant in absolute value.

There are 2 setpoints: dTs1, dTs2 and, therefore, you can have the following 2 situations:

- dTs1 different from dTs2:

In this case there are 5 configurable operation intervals in which the dTs setpoint can vary depending on the temperature T or T1 as shown in the following example:

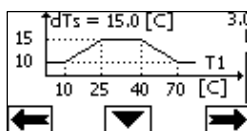

1) If  $T1 \leq 10^{\circ}\text{C} \Rightarrow dTs = |T-T1| = 10^{\circ}\text{C}$

In this case, when the temperature T1 is less than or equal to 10°C, the circulator operates by acting on the flow rate to keep the absolute difference between T and T1 constant at 10°C.

This temperature range can be useful in the ramp up phase of the thermal machine where it is more important to have a rapid achievement of environmental comfort rather than a higher DT (case of air conditioning).

2) If  $10 \leq T1 \leq 25^{\circ}\text{C} \Rightarrow 10^{\circ}\text{C} \leq dTs = |T-T1| \leq 15^{\circ}\text{C}$ , for example if  $T1 = 20^{\circ}\text{C} \Rightarrow dTs = |T-T1| = 13.33^{\circ}\text{C}$

when the temperature T1 is between 10°C and 25°C, the circulator works to keep the absolute difference between T and T1 constant at a dTs proportional to the temperature recorded by T1. For example, when T1= 20°C, the circulator keeps the absolute difference between T and T1 constant at 13.33°C.

3) If  $25^{\circ}\text{C} \leq T1 \leq 40^{\circ}\text{C} \Rightarrow dTs = |T-T1| = 15^{\circ}\text{C}$

when the temperature T1 is between 25°C and 40°C, the circulator works to keep the absolute difference between T and T1 constant at 15°C

4) If  $40^{\circ}\text{C} \leq T1 \leq 70^{\circ}\text{C} \Rightarrow 10^{\circ}\text{C} \leq dTs = |T-T1| \leq 15^{\circ}\text{C}$ , for example if  $T1 = 50^{\circ}\text{C} \Rightarrow dTs = |T-T1| = 13.75^{\circ}\text{C}$

when the temperature T1 is between 40°C and 70°C, the circulator works to keep the absolute difference between T and T1 constant at a dTs inversely proportional to the temperature recorded by T1. For example, when T1= 50°C, the circulator keeps the absolute difference between T and T1 constant at 13.75°C.

5) If  $T1 \geq 70^{\circ}\text{C} \Rightarrow dTs = |T-T1| = 10^{\circ}\text{C}$

Finally, when the temperature T1 is higher than 70°C, the circulator works to keep the absolute difference between T and T1 constant at 10°C.

This temperature range can be useful in the ramp up phase of the thermal machine where it is more important to have a rapid achievement of environmental comfort rather than a higher DT (case of heating).

N.B.: The parameters dTs1 and dTs2 and the values of the operating ranges can be set by the user.

- dTs1 = dTs2

In this case the dTs setpoint is constant when the temperature T or T1 changes, as shown in the following example:

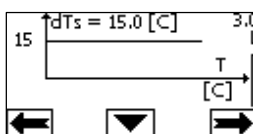

In this case the circulator increases or decreases the flow rate to keep the absolute difference between T and T1 constant at dTs = 15°C.

N.B.: The parameter dTs can be set by the user.

**7.2 Quick Start function**

This function can be useful when it is necessary to guarantee an immediate flow rate, in order to avoid a possible boiler block at the moment of ignition. As long as input I3 is enabled, the pump remains at the preset frequency Fq (see advanced menu). In twin groups, this input can be used independently.

**8. CONTROL PANEL**

The functions of the MCE-22/C may be modified by means of the control panel on the cover of the MCE-22/C itself.

On the panel there are: a graphic display, 7 navigation buttons and 3 LED warning lights (see Figure 10).

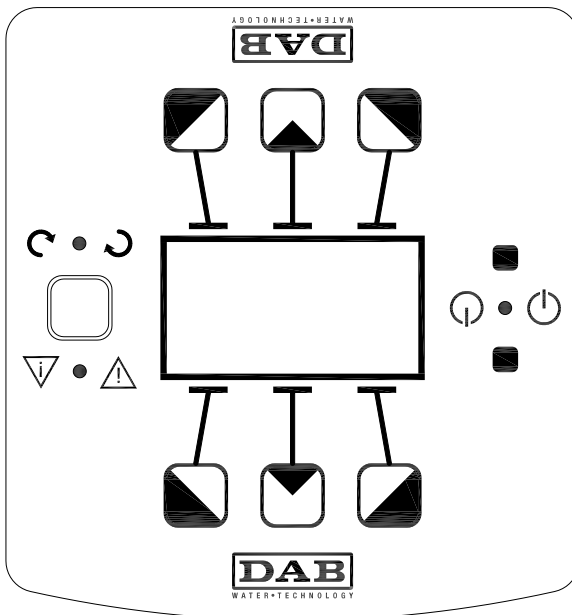

Figure 10: Control Panel

**8.1 Graphic Display**

Using the graphic display it will be possible to navigate in an easy and intuitive menu which will enable you to check and modify the system operating mode, the enabling of the inputs and the working set-point. It will also be possible to view the system status and the log of any alarms memorised by the system.

**8.2 Navigation Buttons**

7 buttons are provided for navigating in the menu: 3 buttons under the display, 3 above it and 1 at the side. The buttons under the display are called *active buttons*, the buttons above the display are called *inactive buttons*, and the button at the side is called *hidden button*.

Each page of the menu is made in such a way as to indicate the function associated with the 3 active buttons (the ones under the display).

Pressing the inactive buttons (the ones above the display) produces the effect of inverting the graphics and the buttons that were active become inactive and vice versa. This function also allows the control panel to be installed “upside down”!

**8.3 Warning Lights**

**Yellow light:** System live signal.  
If lit, it means that the system is live.



**Never remove the cover if the yellow light is lit.**

**Red light:** Warning of an **alarm/malfunction present** in the system.  
If the light is blinking it is a non-blocking alarm and the pump can still be controlled. If the light is fixed it is a blocking alarm and the pump cannot be controlled.

**Green light:** Pump **ON/OFF** signal.  
If On, the pump is running. If Off, the pump is stopped.

**9. MENU**

MCE/C provides 2 menus: user menu and advanced menu.

The user menu is accessible from the Home Page by briefly pressing the central button “Menu”.

The advanced menu is accessible from the Home Page by pressing the central button “Menu” for 5 seconds.

If the menu pages show a key at bottom left it means that it is not possible to change the settings. To unblock the menu go to the Home Page and press the hidden button and the button under the key at the same time until the key disappears.

**If no button is pressed for 60 minutes, the settings are automatically blocked and the display switches off. When any button is pressed the display lights up again and the “Home Page” appears.**

To navigate in the menu, press the central button.

To return to the previous page, hold down the hidden button, then press and release the central button.



To modify the settings use the left and right buttons.







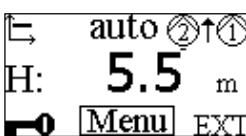
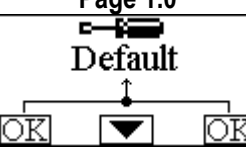



To confirm the change of a setting, hold down the central button “OK” for 3 seconds. Confirmation will be indicated by the following icon: ▼||OK

Table 6 describes the parameters sensitive to the inverter and provided in the advanced menu. To exit the advanced menu, scroll through all parameters using the central button.

Parameter symbol	Description	Range			Measurement unit
Serial	Unique serial number attributed for connectivity	-			-
Fn	Electric pump rated frequency Set the value stated on the electric pump dataplate.	50 - 200			Hz
In	Electric pump rated current Set the value stated on the electric pump dataplate.	MCE-11 1.0 - 6.5	MCE-15 1.0 - 8.0	MCE-22 1.0 - 10.5	A
Rt	Direction of rotation. Modify this parameter to invert the direction of rotation.	0 - 1			--
Fm	Minimum rotation frequency of the electric pump.	0 - (8/10)*Fn			Hz
FM	Maximum rotation frequency of the electric pump	(8/10)*Fn - Fn			Hz
Fq	Quick start frequency	3/10*Fn-Fn			Hz
SM	Numero di giri al minuto massimo dell'elettropompa.	12*Fn - 60*Fn			r.p.m.
--	Differential pressure type of sensor	Ratiometric with fs = 4 bar Ratiometric with fs = 10 bar			--
H0	Maximum electric pump head.	2.0 -fs pressure sensor			m
Fc	Inverter carrier frequency	5 - 20			kHz
DR	Dry running power. If you want to enable protection against dry running, set the value of the absorbed power at Fn (normal frequency) in dry running conditions, increased by 20%.	--			W
ET	Time that passes between switching off one pump and switching on the other in twin systems.	0.0 - 15.0			s
B	Characteristic constant of the NTC resistance, used for the measurement of fluid temperatures T and T1	1-10000			°K
Td	Running time of the hydraulic circuit, it acts in an inversely proportional way on the regulating speed in the T and DT regulations.	0-1800			s
Bs	Parameter for setting up Booster mode	0-80			%
Ad	Modbus address of the device	1-247			
Br	Serial communication baud rate	1.2, 2.4, 4.8, 9.6, 19.2, 38.4			Kb/s
Pa	Type of parity control	None, Odd, Even			
Sb	Number of stop bits	1-2			
Rd	Minimum response time	0-3000			ms
En	Modbus enabling	Disable, Enable			

Table 6: Advanced menu – Sensitive inverter parameters

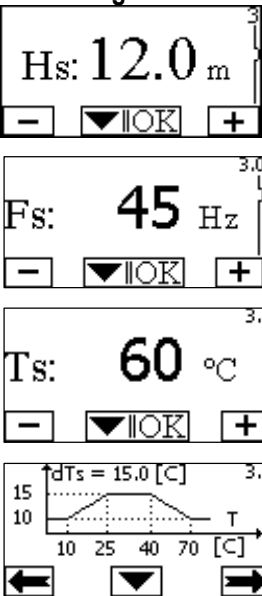
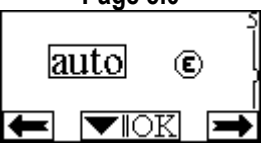

<p><b>Home Page</b></p> 	<p>The main settings of the system are graphically summed up on the Home Page.</p> <p>The icon at top left indicates the type of regulation selected.</p> <p>The icon at centre top indicates the operating mode selected (auto or economy).</p> <p>The icon at top right indicates the presence of a single ① or twin inverter ②/①. The rotation of the icon ① or ② indicates which circulation pump is operating.</p> <p>At the centre of the Home Page is a read-only parameter which can be chosen from a small set of parameters on Page 8.0 of the menu.</p> <p>From the Home Page it is possible to access the page for <b>regulating the contrast</b> of the display: hold down the hidden button, then press and release the right button.</p> <p>From the Home Page it is also possible to access the read-only menu of the <b>inverter sensitive parameters</b> set in the factory: hold down the central button for 3 seconds.</p>
<p><b>Page 1.0</b></p> 	<p>The factory settings are set from Page 1.0 by holding down the left and right buttons at the same time for 3 seconds.</p> <p>The resetting of the factory settings will be notified by the appearance of the symbol  next to the word "Default".</p>

<p><b>Page 2.0</b></p>	<p>The regulating mode is set from Page 2.0. It is possible to choose from 9 different modes:</p> <ol style="list-style-type: none"> <li> = Regulation with constant differential pressure</li> <li> = Regulation with constant curve with speed set from the display.</li> <li> = Regulation with constant curve with speed set by remote signal 0-10V.</li> <li> = Proportional differential pressure regulation.</li> <li> = T constant regulation increasing mode</li> <li> = T constant regulation decreasing mode</li> <li> = T1 constant regulation increasing mode</li> <li> = T1 constant regulation decreasing mode</li> <li> = ΔT constant regulation</li> </ol> <p>Page 2.0 displays the three icons which represent:</p> <ul style="list-style-type: none"> <li>– central icon = setting currently selected</li> <li>– right icon = next setting</li> <li>– left icon = previous setting</li> </ul>
<p><b>Page 3.0</b></p> 	<p>The regulating set-point is set from Page 3.0.</p> <p>Depending on the type of regulation chosen on the previous page, the set-point to be set will be a head (Hs), a frequency (Fs), a temperature (Ts) or a difference in temperature (dTs).</p>
<p><b>Page 5.0</b></p> 	<p>Page 5.0 is displayed in all pressure regulating modes and allows the setting of “auto” or “economy” operating mode.</p> <p>“Auto” mode disables the reading of the status of digital input I2 and in fact the system always activates the set-point set by the user.</p> <p>“Economy” mode enables the reading of the status of digital input I2. When input I2 is energised the system activates a percentage reduction of the set-point set by the user (Page 6.0).</p> <p>For the connection of the inputs see par. 5.5.1</p>
<p><b>Page 6.0</b></p> 	<p>Page 6.0 is displayed if “economy” mode has been chosen on page 5.0 and allows setting of the percentage reduction value of the set-point.</p> <p>This reduction will be carried out if digital input I2 is energised.</p>



<p><b>Page 7.0</b></p>	<p>If a twin system is used (see <i>Par. 0</i>), on page 7.0 you can set one of the 4 possible twin operating modes:</p> <p><b>2/1</b> <b>Alternate every 24h:</b> The 2 inverters alternate in regulation every 24 operating hours. If one of the 2 malfunctions, the other takes over regulation.</p> <p><b>2+1</b> <b>Simultaneous:</b> The 2 inverters work at the same time and at the same speed. This mode is useful when a flow rate is required that cannot be provided by a single pump.</p> <p><b>2-1</b> <b>Main/Reserve:</b> Regulation is always performed by the same inverter (Main), the other (Reserve) takes over only if there is a malfunction of the Main one.</p> <p><b>2↑1</b> <b>Booster:</b> The 2 inverters work <b>simultaneously</b> or <b>alternately every 24 hours:</b></p> <ul style="list-style-type: none"> <li>- In the case of flow rates that can be delivered by a single pump, it works in alternating mode every 24 hours.</li> <li>- In the case of flow rates that cannot be delivered by a single pump, it works in simultaneous mode</li> </ul> <p>N.B: the Booster mode can be activated only in case of constant differential pressure regulation and proportional differential pressure regulation.</p> <p>If the twin communication cable is disconnected the systems automatically configure as <i>Single</i>, working completely independent of each other.</p>
<p><b>Page 8.0</b></p>	<p>On page 8.0 it is possible to choose the parameter to be displayed on the Home Page:</p> <p><b>H:</b> Measured head expressed in metres</p> <p><b>Q:</b> Estimated flow rate expressed in m<sup>3</sup>/h</p> <p><b>RPM:</b> Rotation speed expressed in revs per minute (rpm)</p> <p><b>V:</b> Voltage measured on the analogue input 0-10V</p> <p><b>P:</b> Power distributed expressed in kW</p> <p><b>H:</b> Operating hours</p> <p><b>T1:</b> Liquid temperature measured on the input "A1V" (<b>18-pole terminal block</b>)</p> <p><b>T2:</b> Liquid temperature measured on the input "A2V" (<b>18-pole terminal block</b>)</p> <p><b>ΔT:</b> <b>Temperature difference of the liquid T-T1 in absolute value</b></p>
<p><b>Page 9.0</b></p>	<p>On page 9.0 you can choose the language in which to display the messages.</p>
<p><b>Page 10.0</b></p>	<p>On page 10.0 you can display the alarms log by pressing the right button.</p>
<p><b>Alarms Log</b></p>	<p>If the system finds any faults it records them permanently in the alarms log (up to a maximum of 15 alarms). For each recorded alarm a page composed of 3 parts is displayed: an alphanumeric code that identifies the type of fault, a symbol that illustrates the fault in graphic mode, and a message in the language selected on Page 9.0, giving a brief description of the fault.</p> <p>By pressing the right button you can scroll through all the pages of the log.</p> <p>2 questions appear at the end of the log:</p> <ol style="list-style-type: none"> <li>1. <b>"Reset Alarms?"</b> Pressing OK (left button) resets any alarms still present in the system.</li> <li>2. <b>"Delete Alarms Log?"</b> Pressing OK (left button) deletes the alarms memorised in the log.</li> </ol>
<p><b>Page 11.0</b></p>	<p>On page 11.0 you can set the system status in ON, OFF or controlled by a remote signal EXT (digital input I1).</p> <p>If ON is selected the pump is always on.</p> <p>If OFF is selected the pump is always off.</p> <p>If EXT is selected, reading of the status of digital input I1 is enabled. When input I1 is energised the system goes ON and the pump is started (on the Home Page the messages "EXT" and "ON" appear alternately at bottom right); when input I1 is not energised the system goes OFF and the pump goes off (on the Home Page the messages "EXT" and "OFF" appear alternately at bottom right).</p> <p>For the connection of the inputs see par. 5.5.1</p>

## 10. FACTORY SETTINGS

Parameter	Value
Regulating mode	 = Regulation with constant differential pressure
Hs (Differential Pressure Set-point)	50% of the max. pump head (see inverter sensitive parameters set in factory)
Fs (Frequency Set-point)	90% of the pump rated frequency
Tmax	50 °C
Operating mode	auto
Set-point reduction percentage	50 %
Twin operating mode	 = Alternate every 24h
Pump start control	EXT (from remote signal on input I1).

## 11. TYPES OF ALARM













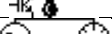
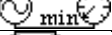

Alarm Code	Alarm Symbol	Alarm Description
e0 - e16; e21		Internal Error
e17 - e19		Short Circuit
e20		Voltage Error
e22 - e30		Voltage Error
e31		Protocol Error
e32 - e35		Excess temperature
e37		Low voltage
e38		High voltage
e39 - e40		Excess current
e42		Dry operation
e43; e44; e45; e54		Pressure Sensor
e46		Pump Disconnected
		Booster mode activated in an operation mode not allowed.
e55		Temperature sensor T error
e56		Temperature sensor T1 error

Table 7: List of Alarms

## 12. MODBUS MCE-C

The use of the Modbus protocol is allowed, through the installation of the cable kit 60193518 MCE MODBUS CABLE KIT. For more information, see the web page <https://dabpumps.com/mce-c>.

## 13. BACNET

The use of the Bacnet protocol is allowed, through the installation of a Bacnet-Modbus gateway. For more information and access to the list of recommended devices, see the web page <https://dabpumps.com/mce-c>.