



TECHNICAL DATA

Performance range: flow up to 75 m³/h and max head of 670 m

Max. quantity of sand/silt: 50g/m³

Max. ambient temperature: 30°C (50°C available on request)

Outlet connection diameter (inside threaded): SS6 A – SS6 B : 2 ½"
SS6 C : 3"
SS6 D – SS6 E : 4"

Nr of starts: refer to the motor specification

Motor Cooling flow: refer to the motor specification

Installation: horizontal or vertical, refer to the motor specification

APPLICATIONS

Multistage mixed-flow borehole electric pumps, completely made in stainless steel (AISI 304L or AISI 316 on request), usable for wells from a minimum diameter equal to pump size or greater and capable of developing a wide range of Flows and Heads.

These pumps can be used in a wide range of lifting, distributing, and pressuring application: domestic and general water supply; sprinkler and drip irrigations systems; fire-fighting installations; lowering of groundwater level; industrial supplies as mining, hot springs, autoclaves and tanks.

These pumps are suitable both for standard water and for aggressive water applications by choosing the proper manufacturing material (AISI 304L or AISI 316) both for hydraulic part and motor.

Special version of motors with PE2+PA windings can be used on request for high-temperature water applications up to maximum 50°C.

Pumps can be installed both vertically and horizontally simply by removing the non-return valve and adding a cooling sleeve to the suction case (the only remark is to check the motor applicability to horizontal operations, refer to the motor specifications section).

CONSTRUCTION FEATURES OF PUMP

Mixed flow pumps with diffusers, impellers, brackets, suction case and discharge case completely made of stainless steel AISI 304 in order to provide maximum strength, durability, wear and tear resistance.

The impellers are balanced and locked to the shaft with a specially shaped collet and nut coupling, in order to guarantee ease-to-assembly feature and avoid vibration sensitive malfunctions and noise increase during rotation.

Rubber bearings that drive the shaft are water lubricated and have sand channels to make enable the sand particles leave the pump with the pumped liquid (maximum permissible sand content 50 gr/m³).

Built-in non returned valve provided in order to minimize local friction losses.

Stainless steel strainer provided in order to prevent particles over a certain size from entering the pump.

Coupling with 6", 8" or 10" motor depending on the power requested by hydraulic part:

- 6GF: 6" canned submersible motor
- TR6: 6" rewindable submersible motor
- TR8: 8" rewindable submersible motor
- TR10: 10" rewindable submersible motor

For inverter application refer to the detailed motor specification.

ON REQUEST:

- Pump body stainless steel AISI 316 for aggressive water application
- Impellers stainless steel AISI 316
- Motors in full stainless steel AISI 316 for aggressive water application
- Star/Delta starting version
- Special version of the motor for high temperature application
- Non-standard power coupling

MATERIALS

N°	PART NAME	MATERIAL
1	Suction Case	Stainless Steel (AISI 304L)
2	Filter	Stainless Steel (AISI 304L)
3	Suction Case Wear Ring	Bronze (ASTM B145-4A)
4	Pump Shaft	Stainless Steel (AISI 420)
5	Collet	Stainless Steel
6	Impeller Wear Ring	STAINLESS STEEL (AISI 304)
7	Impeller	Stainless Steel (AISI 304L)
8	Diffuser	Stainless Steel (AISI 304L)
9	Rubber Bearing	Rubber
10	Diffuser Wear Ring	Rubber
11	Nut for Stop Ring	Stainless Steel (AISI 304L)
12	Bearing	Rubber
13	Shaft Stopper	Bronze (ASTM B145-4A)
14	Valve	Stainless Steel (AISI 304)
15	Discharge Case	Stainless Steel (AISI 304)
16	TIE ROD	STAINLESS STEEL (AISI 304L)
17	CABLE GUARD	STAINLESS STEEL (AISI 304)
18	TIR ROD NUT	STAINLESS STEEL (AISI 303)
19	NAME PLATE	STAINLESS STEEL (AISI 304)

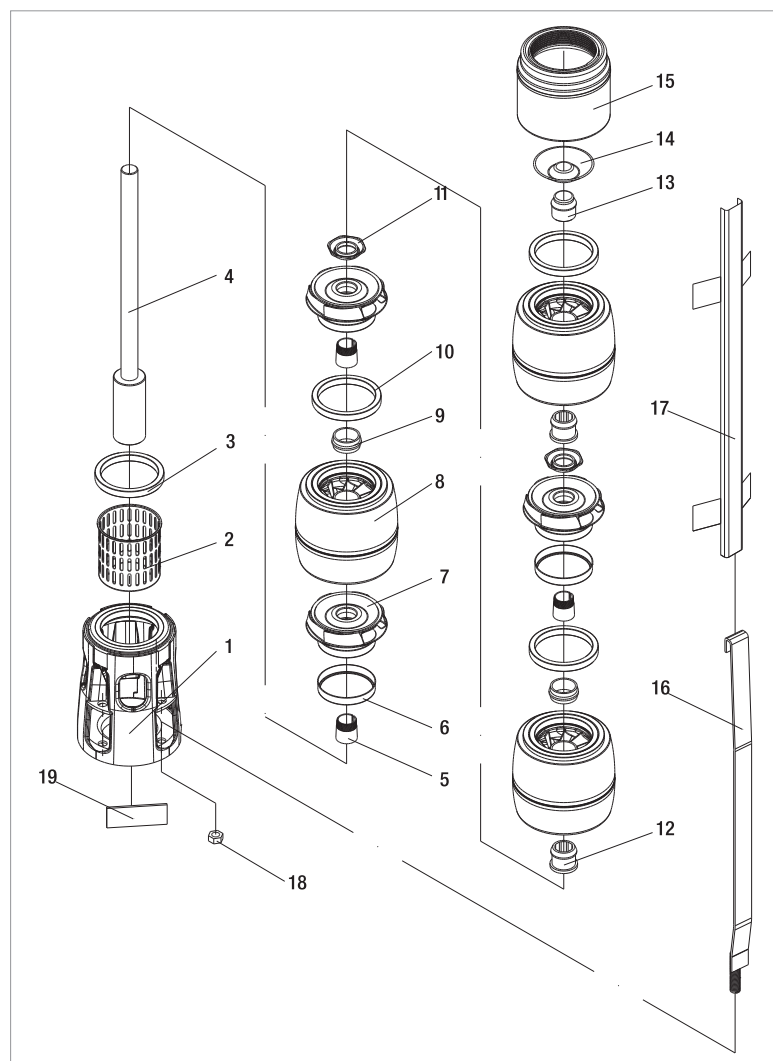

- Denomination index:
(EXAMPLE)

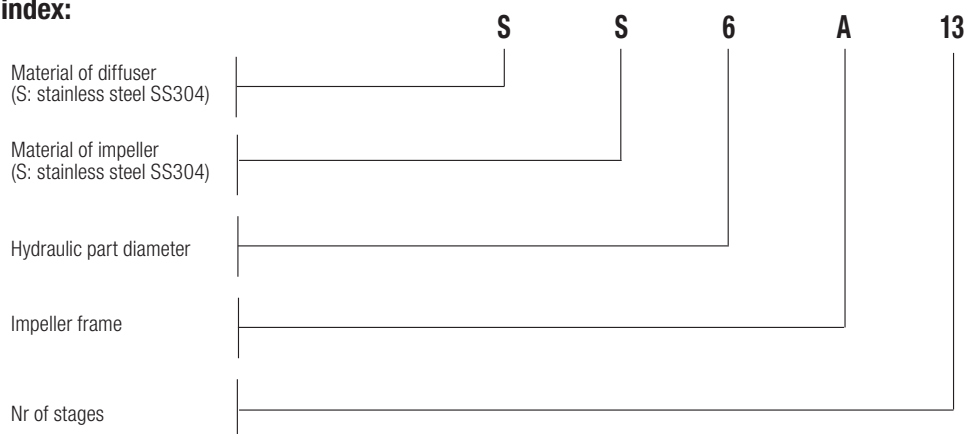

PERFORMANCE 50 Hz - 2 POLES

MODEL	ELECTRICAL DATA		HYDRAULIC DATA											STANDARD MOTOR COUPLING
	P2 NOMINAL		Q=m ³ h	0	2	4	6	8	10	12	14	16	17	
	kW	HP	Q=l/min	0	33,3	66,6	100	133,3	166,6	200	233,3	266,6	283,3	
SS6A 08	4	5,5	H (mt)	75	75	74	73	70	65	59	51	41	36	6"
SS6A 09	4	5,5		84	84	84	82	78	73	66	57	46	40	6"
SS6A 10	4	5,5		93	94	93	91	87	81	73	63	51	44	6"
SS6A 11	4	5,5		103	103	102	100	96	89	81	70	56	49	6"
SS6A 12	5,5	7,5		112	112	112	109	104	97	88	76	61	53	6"
SS6A 13	5,5	7,5		121	122	121	118	113	105	95	82	67	58	6"
SS6A 14	5,5	7,5		131	131	130	127	122	114	103	89	72	62	6"
SS6A 15	5,5	7,5		140	140	139	136	130	122	110	95	77	67	6"
SS6A 16	7,5	10		149	150	149	145	139	130	117	101	82	71	6"
SS6A 17	7,5	10		159	159	158	154	148	138	124	108	87	76	6"
SS6A 18	7,5	10		168	169	167	163	156	146	132	114	92	80	6"
SS6A 19	7,5	10		177	178	177	172	165	154	139	120	97	84	6"
SS6A 20	7,5	10		187	187	186	182	174	162	146	127	102	89	6"
SS6A 21	7,5	10		196	197	195	191	182	170	154	133	108	93	6"
SS6A 22	9,2	12,5		205	206	204	200	191	178	161	139	113	98	6"
SS6A 23	9,2	12,5		215	215	214	209	200	186	168	146	118	102	6"
SS6A 24	9,2	12,5		224	225	223	218	209	195	176	152	123	107	6"

ELECTRICAL DATA AND DIMENSIONS

MODEL	MOTOR *	ELECTRICAL DATA			OPERATING BY INVERTER	HORIZONTAL INSTALLATION	L2 mm	L mm	L1 mm	D mm	D1 mm	TOTAL WEIGHT Kg
		P2 NOMINAL		In A								
		kW	HP									
SS6A 08	6GF	4	5,5	10,6	●	●	1353	600	753	141	132	54,4
SS6A 09	6GF	4	5,5	10,6	●	●	1414	600	814	141	132	56,4
SS6A 10	6GF	4	5,5	10,6	●	●	1474	600	874	141	132	57,4
SS6A 11	6GF	4	5,5	10,6	●	●	1535	600	935	141	132	59,4
SS6A 12	6GF	5,5	7,5	14	●	●	1626	631	995	141	132	63,6
	TR6	5,5	7,5	13	○	●	1802	807	995	144	132	71
SS6A 13	6GF	5,5	7,5	14	●	●	1687	631	1056	141	132	65,6
	TR6	5,5	7,5	13	○	●	1863	807	1056	144	132	73
SS6A 14	6GF	5,5	7,5	14	●	●	1747	631	1116	141	132	66,6
	TR6	5,5	7,5	13	○	●	1923	807	1116	144	132	74
SS6A 15	6GF	5,5	7,5	14	●	●	1808	631	1177	141	132	68,6
	TR6	5,5	7,5	13	○	●	1984	807	1177	144	132	76
SS6A 16	6GF	7,5	10	18	●	●	1897	660	1237	141	132	72,2
	TR6	7,5	10	18	○	●	2074	837	1237	144	132	80
SS6A 17	6GF	7,5	10	18	●	●	1958	660	1298	141	132	73,2
	TR6	7,5	10	18	○	●	2135	837	1298	144	132	81
SS6A 18	6GF	7,5	10	18	●	●	2018	660	1358	141	132	75,2
	TR6	7,5	10	18	○	●	2195	837	1358	144	132	83
SS6A 19	6GF	7,5	10	18	●	●	2079	660	1419	141	132	76,2
	TR6	7,5	10	18	○	●	2256	837	1419	144	132	84
SS6A 20	6GF	7,5	10	18	●	●	2139	660	1479	141	132	78,2
	TR6	7,5	10	18	○	●	2316	837	1479	144	132	86
SS6A 21	6GF	7,5	10	18	●	●	2200	660	1540	141	132	79,2
	TR6	7,5	10	18	○	●	2377	837	1540	144	132	87
SS6A 22	6GF	9,2	12,5	22	●	●	2285	685	1600	141	132	84,6
	TR6	9,2	12,5	21	○	●	2467	867	1600	144	132	91
SS6A 23	6GF	9,2	12,5	22	●	●	2346	685	1661	141	132	85,6
	TR6	9,2	12,5	21	○	●	2528	867	1661	144	132	92
SS6A 24	6GF	9,2	12,5	22	●	●	2406	685	1721	141	132	87,6
	TR6	9,2	12,5	21	○	●	2588	867	1721	144	132	94

* Motor 6GF: 6" canned submersible motors.

Motor TR6: 6" rewindable submersible motors.

●	Allowed
○	Only PE2 + PA version

SS6A

SUBMERSIBLE ELECTRIC PUMPS 6"

The performance curves are based on the kinematic viscosity values = 1 mm²/s and density equal to 1000 Kg/m³. Curve tolerance according to ISO 9906.

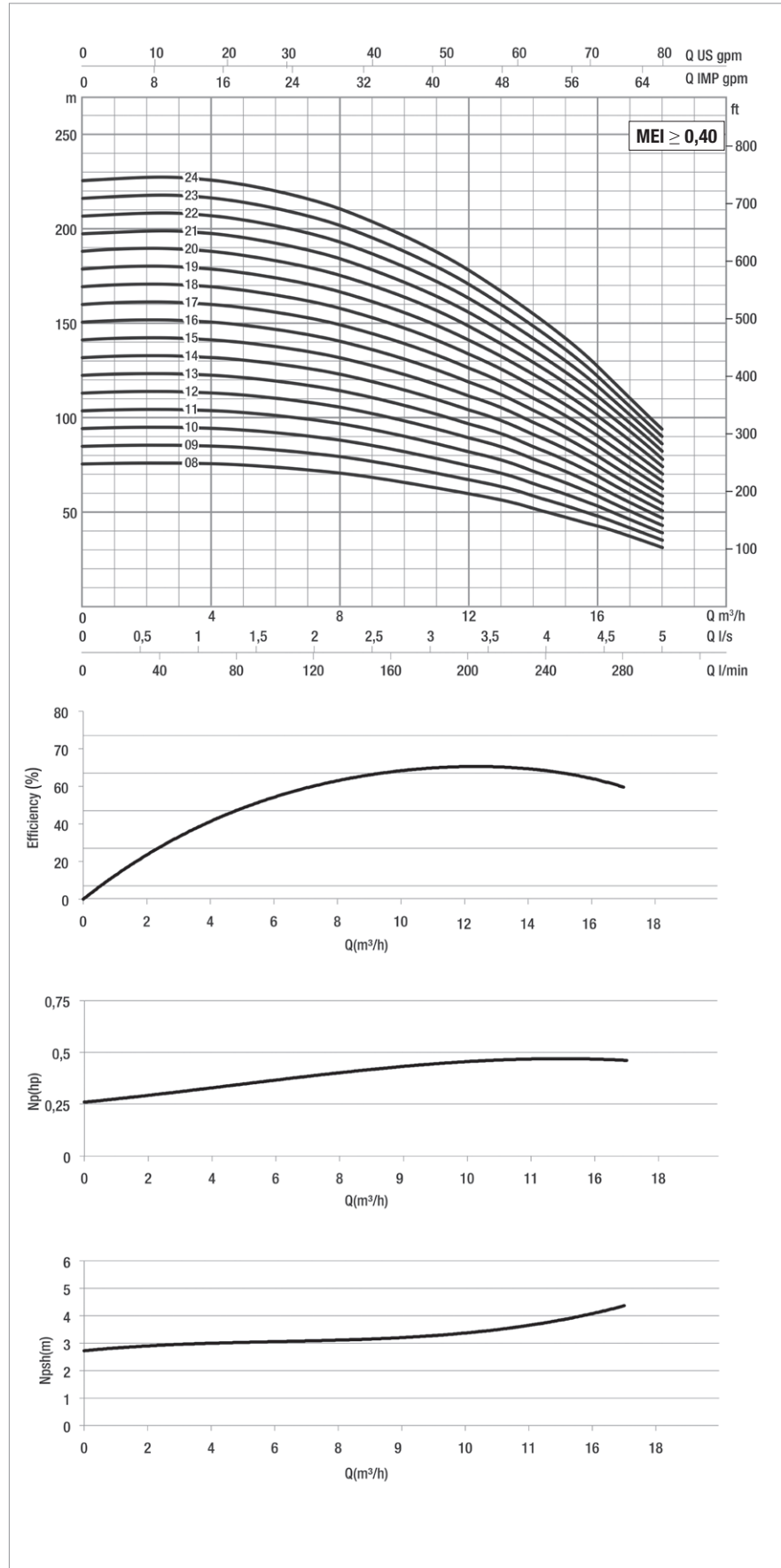
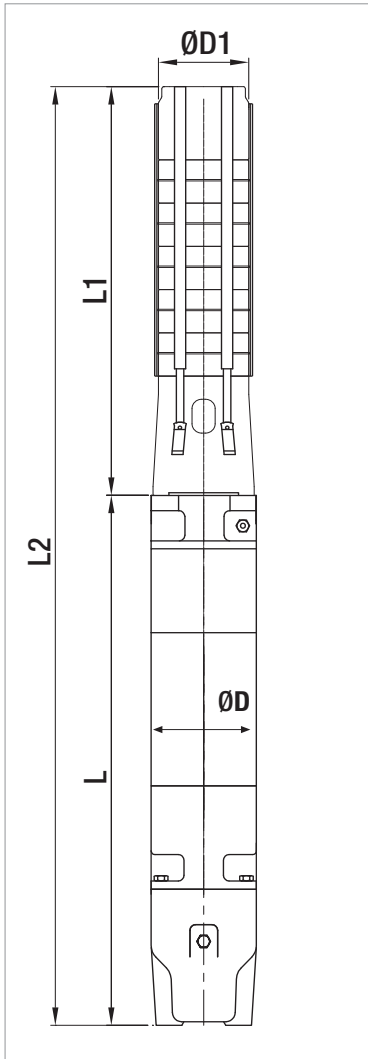

For hydraulic efficiency see pag. 233

PERFORMANCE 50 Hz - 2 POLES

MODEL	ELECTRICAL DATA		HYDRAULIC DATA											STANDARD MOTOR COUPLING
	P2 NOMINAL		Q=m ³ h	0	2	4	6	8	10	12	14	16	17	
	kW	HP	Q=l/min	0	33,3	66,6	100	133,3	166,6	200	233,3	266,6	283,3	
SS6A 25	9,2	12,5	H (m)	233	234	232	227	217	203	183	158	128	111	6"
SS6A 26	9,2	12,5		243	244	242	236	226	211	190	165	133	116	6"
SS6A 27	11	15		252	253	251	245	235	219	198	171	138	120	6"
SS6A 28	11	15		261	262	260	254	243	227	205	177	143	124	6"
SS6A 29	11	15		270	272	270	263	252	235	212	184	149	129	6"
SS6A 30	11	15		280	281	279	272	261	243	220	190	154	133	6"
SS6A 31	13	17,5		289	290	288	281	269	251	227	196	159	138	6"
SS6A 32	13	17,5		298	300	297	290	278	259	234	202	164	142	6"
SS6A 33	13	17,5		308	309	307	300	287	268	242	209	169	147	6"
SS6A 34	13	17,5		317	318	316	309	295	276	249	215	174	151	6"
SS6A 35	13	17,5		326	328	325	318	304	284	256	221	179	156	6"
SS6A36	13	17,5		336	337	335	327	313	292	264	228	184	160	6"
SS6A 37	13	17,5		345	347	344	336	321	300	271	234	190	164	6"
SS6A 38	15	20		354	356	353	345	330	308	278	240	195	169	6"
SS6A 39	15	20		364	365	362	354	339	316	286	247	200	173	6"
SS6A 40	15	20		373	375	372	363	348	324	293	253	205	178	6"
SS6A 41	15	20		382	384	381	372	356	332	300	259	210	182	6"
SS6A 42	18,5	25		392	393	390	381	365	341	308	266	215	187	6"

ELECTRICAL DATA AND DIMENSIONS

MODEL	MOTOR *	ELECTRICAL DATA				HORIZONTAL INSTALLATION	L2 mm	L mm	L1 mm	D mm	D1 mm	TOTAL WEIGHT Kg
		P2 NOMINAL		In A	OPERATING BY INVERTER							
		kW	HP									
SS6A 25	6GF	9,2	12,5	22	●	●	2467	685	1782	141	132	88,6
	TR6	9,2	12,5	21	○	●	2649	867	1782	144	132	95
SS6A 26	6GF	9,2	12,5	22	●	●	2527	685	1842	141	132	89,6
	TR6	9,2	12,5	21	○	●	2709	867	1842	144	132	96
SS6A 27	6GF	11	15	25,5	●	●	2633	730	1903	141	132	96
	TR6	11	15	25	○	●	2800	897	1903	144	132	103
SS6A 28	6GF	11	15	25,5	●	●	2693	730	1963	141	132	97
	TR6	11	15	25	○	●	2860	897	1963	144	132	104
SS6A 29	6GF	11	15	25,5	●	●	2754	730	2024	141	132	99
	TR6	11	15	25	○	●	2921	897	2024	144	132	106
SS6A 30	6GF	11	15	25,5	●	●	2814	730	2084	141	132	100
	TR6	11	15	25	○	●	2981	897	2084	144	132	107
SS6A 31	6GF	15	20	33,4	●	●	2930	785	2145	141	132	108
	TR6	13	17,5	29	○	●	3072	927	2145	144	132	114
SS6A 32	6GF	15	20	33,4	●	●	2990	785	2205	141	132	109
	TR6	13	17,5	29	○	●	3132	927	2205	144	132	115
SS6A 33	6GF	15	20	33,4	●	●	3051	785	2266	141	132	111
	TR6	13	17,5	29	○	●	3193	927	2266	144	132	117
SS6A 34	6GF	15	20	33,4	●	●	3111	785	2326	141	132	112
	TR6	13	17,5	29	○	●	3253	927	2326	144	132	118
SS6A 35	6GF	15	20	33,4	●	●	3172	785	2387	141	132	113
	TR6	13	17,5	29	○	●	3314	927	2387	144	132	119
SS6A 36	6GF	15	20	33,4	●	●	3232	785	2447	141	132	115
	TR6	13	17,5	29	○	●	3374	927	2447	144	132	121
SS6A 37	6GF	15	20	33,4	●	●	3293	785	2508	141	132	116
	TR6	13	17,5	29	○	●	3435	927	2508	144	132	122
SS6A 38	6GF	15	20	33,4	●	●	3353	785	2568	141	132	118
	TR6	15	20	32	○	●	3565	997	2568	144	132	136
SS6A 39	6GF	15	20	33,4	●	●	3664	785	2879	141	167	150
	TR6	15	20	32	○	●	3876	997	2879	144	167	168
SS6A 40	6GF	15	20	33,4	●	●	3724	785	2939	141	167	151
	TR6	15	20	32	○	●	3936	997	2939	144	167	169
SS6A 41	6GF	15	20	33,4	●	●	3785	785	3000	141	167	153
	TR6	15	20	32	○	●	3997	997	3000	144	167	171
SS6A 42	6GF	18,5	25	41	●	●	3920	860	3060	141	167	163
	TR6	18,5	25	39	○	●	4117	1057	3060	144	167	179

* Motor 6GF: 6" canned submersible motors.
 Motor TR6: 6" rewindable submersible motors.

●	Allowed
○	Only PE2 + PA version

SS6A

SUBMERSIBLE ELECTRIC PUMPS 6"

The performance curves are based on the kinematic viscosity values = 1 mm²/s and density equal to 1000 Kg/m³. Curve tolerance according to ISO 9906.

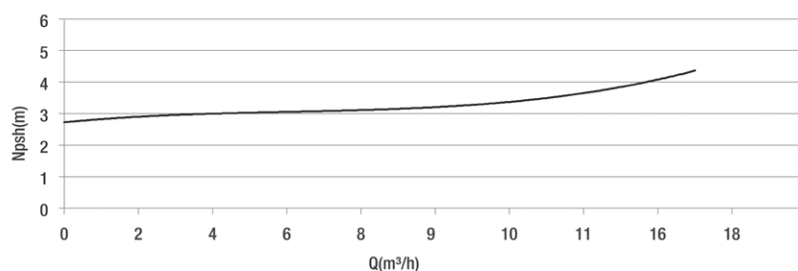
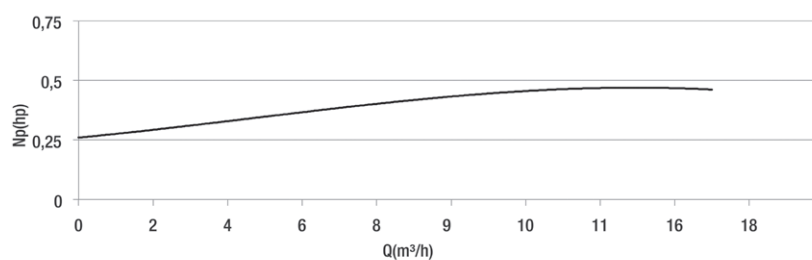
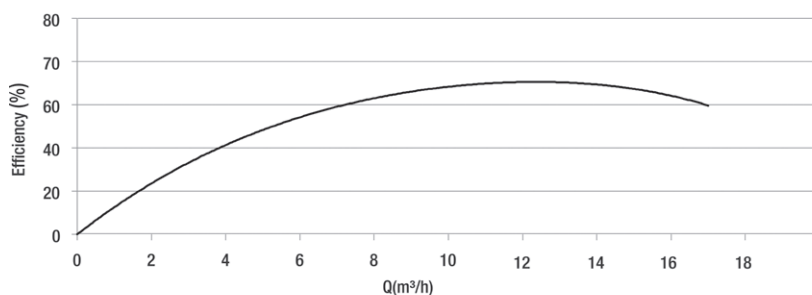
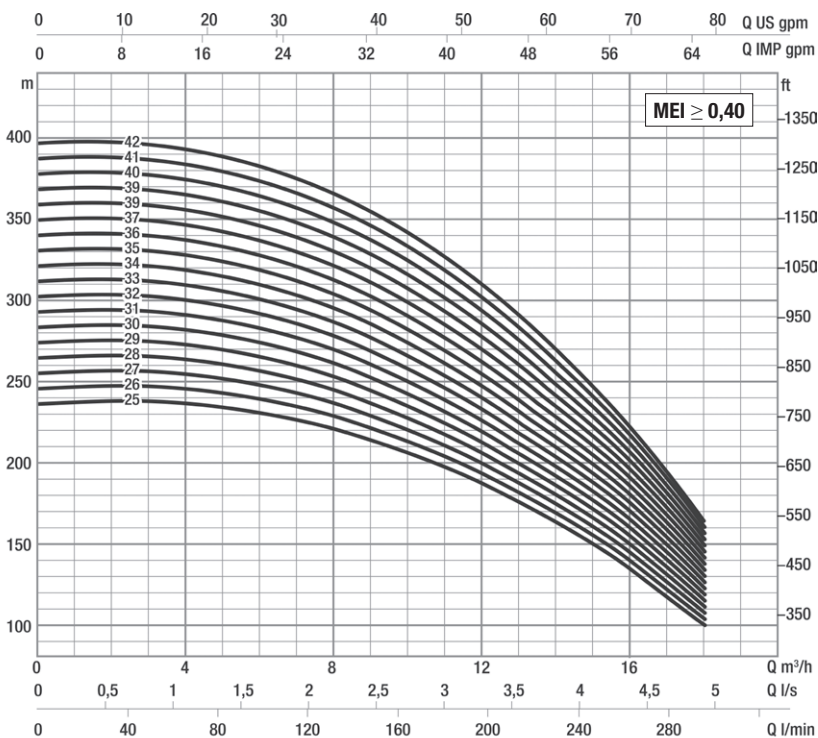
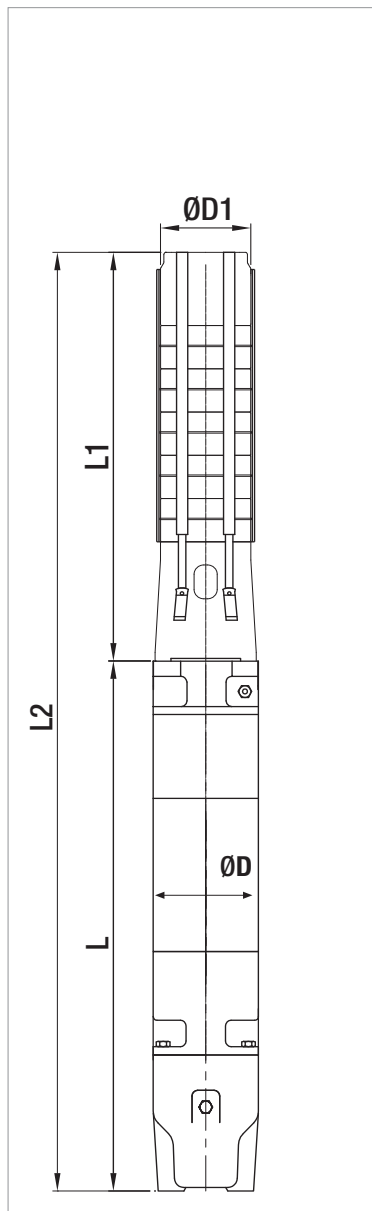

For hydraulic efficiency see pag. 233

PERFORMANCE 50 Hz - 2 POLES

MODEL	ELECTRICAL DATA		HYDRAULIC DATA											STANDARD MOTOR COUPLING
	P2 NOMINAL		Q=m ³ h	0	2	4	6	8	10	12	14	16	17	
	kW	HP	Q=l/min	0	33,3	66,6	100	133,3	166,6	200	233,3	266,6	283,3	
SS6A 43	18,5	25	H (m)	401	403	400	390	374	349	315	272	220	191	6"
SS6A 44	18,5	25		410	412	409	399	382	357	322	278	225	196	6"
SS6A 45	18,5	25		420	421	418	408	391	365	330	285	231	200	6"
SS6A 46	18,5	25		429	431	428	418	400	373	337	291	236	204	6"
SS6A 47	18,5	25		438	440	437	427	408	381	344	297	241	209	6"
SS6A 48	18,5	25		448	450	446	436	417	389	352	304	246	213	6"
SS6A 49	18,5	25		457	459	455	445	426	397	359	310	251	218	6"
SS6A 50	22	30		466	468	465	454	434	405	366	316	256	222	6"
SS6A 51	22	30		476	478	474	463	443	414	373	323	261	227	6"
SS6A 52	22	30		485	487	483	472	452	422	381	329	266	231	6"
SS6A 53	22	30		494	496	493	481	460	430	388	335	272	236	6"
SS6A 54	22	30		504	506	502	490	469	438	395	342	277	240	6"
SS6A 55	22	30		513	515	511	499	478	446	403	348	282	244	6"
SS6A 56	22	30		522	524	520	508	487	454	410	354	287	249	6"
SS6A 57	22	30		532	534	530	517	495	462	417	361	292	253	6"
SS6A 58	22	30		541	543	539	526	504	470	425	367	297	258	6"
SS6A 59	22	30		550	553	548	536	513	478	432	373	302	262	6"
SS6A 60	22	30		560	562	558	545	521	486	439	380	307	267	6"

ELECTRICAL DATA AND DIMENSIONS

MODEL	MOTOR *	ELECTRICAL DATA				HORIZONTAL INSTALLATION	L2 mm	L mm	L1 mm	D mm	D1 mm	TOTAL WEIGHT Kg
		P2 NOMINAL		In A	OPERATING BY INVERTER							
		kW	HP									
SS6A 43	6GF	18,5	25	41	●	●	3981	860	3121	141	167	165
	TR6	18,5	25	39	○	●	4178	1057	3121	144	167	181
SS6A 44	6GF	18,5	25	41	●	●	4041	860	3181	141	167	167
	TR6	18,5	25	39	○	●	4238	1057	3181	144	167	183
SS6A 45	6GF	18,5	25	41	●	●	4102	860	3242	141	167	168
	TR6	18,5	25	39	○	●	4299	1057	3242	144	167	184
SS6A 46	6GF	18,5	25	41	●	●	4162	860	3302	141	167	170
	TR6	18,5	25	39	○	●	4359	1057	3302	144	167	186
SS6A 47	6GF	18,5	25	41	●	●	4223	860	3363	141	167	172
	TR6	18,5	25	39	○	●	4420	1057	3363	144	167	188
SS6A 48	6GF	18,5	25	41	●	●	4283	860	3423	141	167	174
	TR6	18,5	25	39	○	●	4480	1057	3423	144	167	190
SS6A 49	6GF	18,5	25	41	●	●	4344	860	3484	141	167	175
	TR6	18,5	25	39	○	●	4541	1057	3484	144	167	191
SS6A 50	6GF	22	30	47	●	●	4464	920	3544	141	167	180,6
	TR6	22	30	49	○	●	4631	1087	3544	144	167	205
SS6A 51	6GF	22	30	47	●	●	4525	920	3605	141	167	182,6
	TR6	22	30	49	○	●	4692	1087	3605	144	167	207
SS6A 52	6GF	22	30	47	●	●	4585	920	3665	141	167	184,6
	TR6	22	30	49	○	●	4752	1087	3665	144	167	209
SS6A 53	6GF	22	30	47	●	●	4646	920	3726	141	167	186,6
	TR6	22	30	49	○	●	4813	1087	3726	144	167	211
SS6A 54	6GF	22	30	47	●	●	4706	920	3786	141	167	187,6
	TR6	22	30	49	○	●	4873	1087	3786	144	167	212
SS6A 55	6GF	22	30	47	●	●	4767	920	3847	141	167	189,6
	TR6	22	30	49	○	●	4934	1087	3847	144	167	214
SS6A 56	6GF	22	30	47	●	●	4827	920	3907	141	167	191,6
	TR6	22	30	49	○	●	4994	1087	3907	144	167	216
SS6A 57	6GF	22	30	47	●	●	4888	920	3968	141	167	193,6
	TR6	22	30	49	○	●	5055	1087	3968	144	167	218
SS6A 58	6GF	22	30	47	●	●	4948	920	4028	141	167	195,6
	TR6	22	30	49	○	●	5115	1087	4028	144	167	220
SS6A 59	6GF	22	30	47	●	●	5009	920	4089	141	167	196,6
	TR6	22	30	49	○	●	5176	1087	4089	144	167	221
SS6A 60	6GF	22	30	47	●	●	5069	920	4149	141	167	198,6
	TR6	22	30	49	○	●	5236	1087	4149	144	167	223

* Motor 6GF: 6" canned submersible motors.
 Motor TR6: 6" rewindable submersible motors.

●	Allowed
○	Only PE2 + PA version

SS6A

SUBMERSIBLE ELECTRIC PUMPS 6"

The performance curves are based on the kinematic viscosity values = 1 mm²/s and density equal to 1000 Kg/m³. Curve tolerance according to ISO 9906.

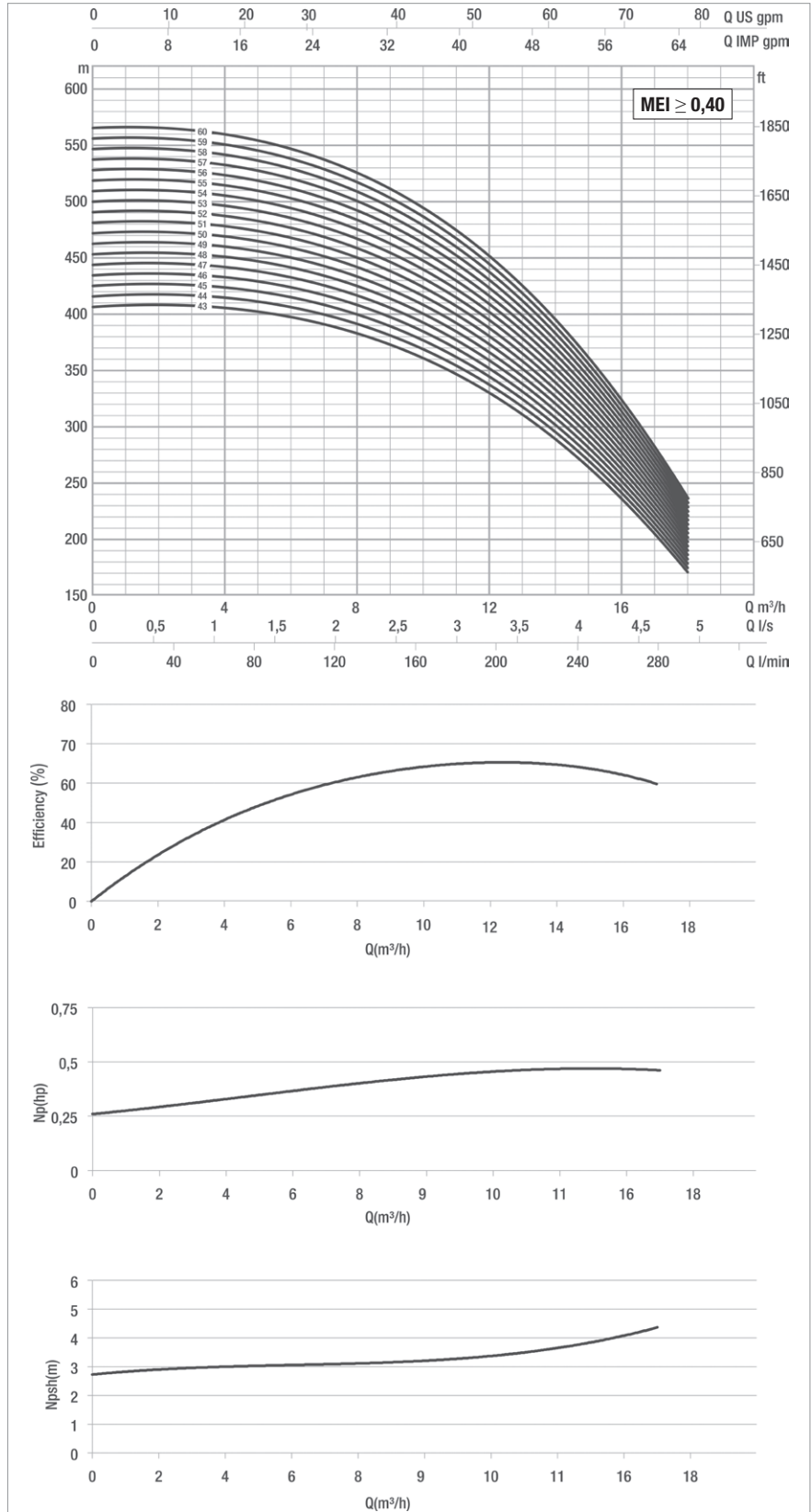
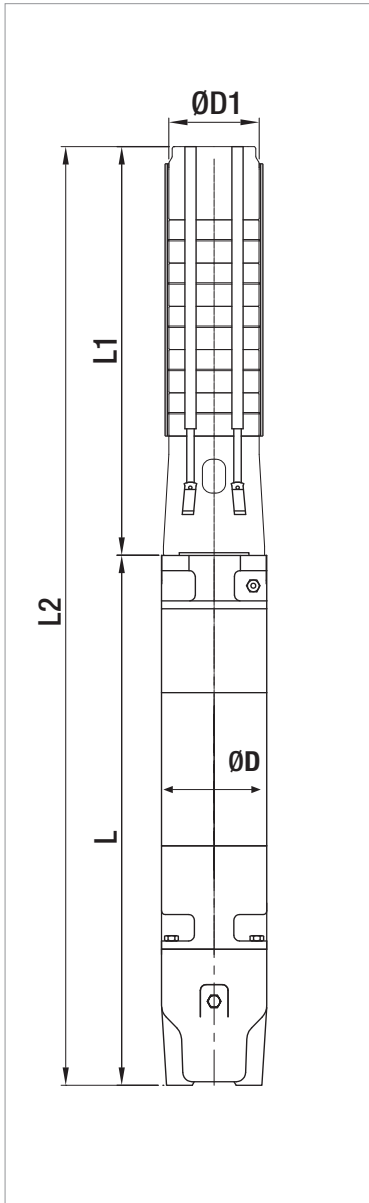

For hydraulic efficiency see pag. 233