

CP / CP-G / DCP / DCP-G

ELECTRIC IN-LINE PUMPS



TECHNICAL DATA

Operating range: from 3,6 to 420 m³/h with head of up to 102 metres.

Pumped liquid: clean, free of solids and abrasives, non-viscous, non-aggressive, non-crystallised and chemically neutral, with properties similar to water. Maximum glycol content 30 % (for other glycol percentages contact Technical Support).

Liquid temperature range:
 from -10 °C to +130 °C for DN 40 - DN 50.
 from -10 °C to +140 °C for the remainder of the range.

Maximum ambient temperature: +40 °C.

Maximum operating pressure:

PN10 : for DN 40 - DN 50.

PN16 : Remainder of the range.

Flanging: PN 16.

Special executions on request: Other voltages and/or frequencies.

Protection: IP 55.

Insulation: class F

APPLICATIONS

In-line port circulation pumps, suitable for heating, air conditioning, refrigeration and sanitary water systems. Available in the single and twin versions.

CONSTRUCTION FEATURES

PN 10 - PN 16 flanged suction and delivery ports with threaded holes for control manometers.

Cast iron pump body and motor support, cast iron or technopolymer impeller depending on mode.

Stainless steel motor shaft.

External ventilation three-phase asynchronous motor. For its protection we recommend the use of remote overload cut-outs, in compliance with current local regulations.

MATERIALS

N.	PARTS*	MATERIALS
1	PUMP BODY	CAST IRON 250 UNI ISO 185
3	SUPPORT	CAST IRON 250 UNI ISO 185
4	IMPELLER	CAST IRON FOR DN 65-80-100-125-150 / DCP Dn 40 - 50 / CP 40-3800T, CP 40-4700T, CP 40-5500T, CP 40-6200T, CP 50-4600T, CP 50-5100T, CP 50-5650T
		TECHNOPOLYMER B FOR CP 40-1900T, CP 40-2300T, CP 40-2700T, CP 40-3500T, CP 50-2200T, CP 50-2600T, CP 50-3100T, CP 50/4100T
7	SHAFT WITH ROTOR	AISI 304 STAINLESS STEEL X5 CrNiS 1809 UNI 6900/71
16	MECHANICAL SEAL	CARBON/GRAPHITE
28	OR RING	EPDM RUBBER

* In contact with the liquid

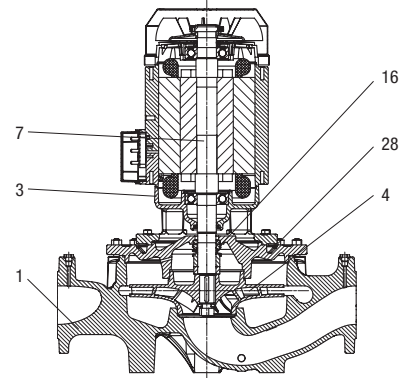

- Denomination index:

(example)

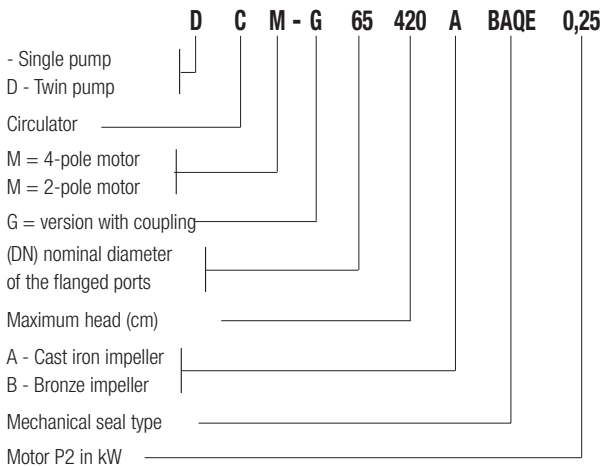

Installation: horizontal or vertical position, provided that the motor is always above the pump.

Vertical installation only for powers exceeding 7,5 kW.

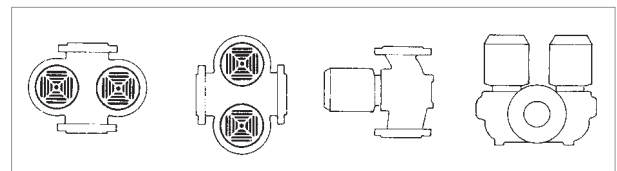
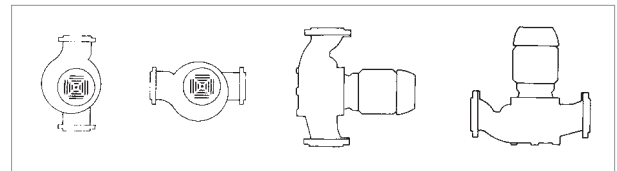

ELECTRIC IN-LINE PUMPS

IN-LINE ELECTRIC PUMPS FOR CIRCULATION SYSTEMS

PERFORMANCE RANGE

The performance curves are based on kinematic viscosity values = 1 mm²/s and density equal to 1000 kg/m³. Curve tolerance according to ISO 9906.

GRAPHIC SELECTION TABLE

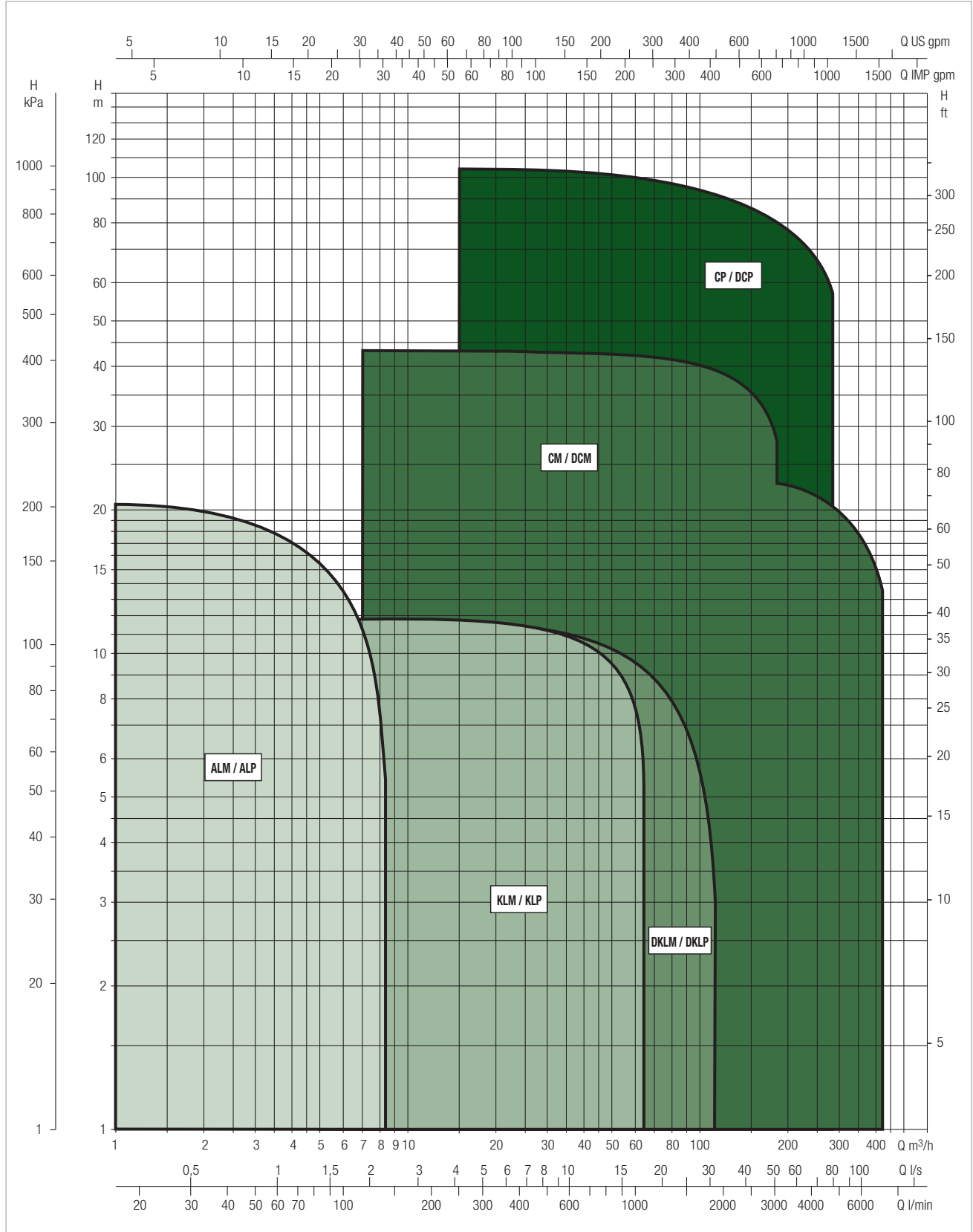

CP / CP-G / DCP / DCP-G

ELECTRIC IN-LINE PUMPS

SELECTION TABLE - CP - 2 POLES

MODEL	Q=m ³ /h	0	3,6	4,8	6	12	18	24	30	36
	Q=l/min	0	60	80	100	200	300	400	500	600
CP 40/1900 T	H (m)	17,6	17,6	17,4	17	14				
CP 40/2300 T		21,8	21,8	21,3	21	18				
CP 40/2700 T		26,9	26,9	26,7	26,2	23,2				
CP 40/3500 T		34,8	34,9	34,7	34,2	31,7				
CP 40/3800 T					38	35	30			
CP 40/4700 T					47	44	39,5	35		
CP 40/5500 T					55	53	48	42		
CP 40/6200 T					62	59	54	49		

MODEL	Q=m ³ /h	0	3,6	4,8	6	12	18	24	30	36
	Q=l/min	0	60	80	100	200	300	400	500	600
CP 50/2200 T	H (m)				20	16,5	11			
CP 50/2600 T					25	22	16			
CP 50/3100 T					31	28,5	24			
CP 50/4100 T					40,7	38,5	34,5	27,7		
CP 50/4600 T							44	41,5	37	31
CP 50/5100 T							50	47,5	42,5	37
CP 50/5650 T							55,5	53	49	44

SELECTION TABLE - CP-G - 2 POLES

MODEL	Q=m ³ /h	0	6	12	18	24	30	36	42	48	54	60	66	72	78	84	90	102	114	120	150		
	Q=l/min	0	100	200	300	400	500	600	700	800	900	1000	1100	1200	1300	1400	1500	1700	1900	2000	2500		
CP-G 65-1470/A/BAQE/1.5	H (m)	14,7	14,5	14,3	13,8	13	11,8	10,5	8,6	7													
CP-G 65-1900/A/BAQE/2.2		19	18,7	18,4	17,8	17	15,9	14,6	13	11													
CP-G 65-2280/A/BAQE/3		22,8	22,5	22,3	22	21,2	20,2	19	17,4	15,5	13,5												
CP-G 65-2640/A/BAQE/4		26,4	26,2	26	25,6	25	24	23	21,5	19,5	17,5	15											
CP-G 65-3400/A/BAQE/5.5		34			34	33,5	32,5	31	29,5	27	24												
CP-G 65-4100/A/BAQE/7.5		41			41	41	40	39	37,5	35,5	33	30	26,5										
CP-G 65-4700/A/BAQE/11		47					45,5	45	44,3	43,3	42	40,8	39	37	35	32,3							
CP-G 65-5500/A/BAQE/15		55					56	55,5	54	53,5	52	51	49	47,5	45,5	43	41						
CP-G 65-6150/A/BAQE/18.5		61,5					62	62	61,5	60,5	59	58	56,5	55	53	51	48,5	43					
CP-G 65-7350/A/BAQE/22		73,5					75	74,5	73,8	73,5	71	68,5	67	65	62,5	60	57	49					
CP-G 65-9250/A/BAQE/30		92,5					94	94	94	93	91	89,4	87,5	85,6	83	81,5	78	72					

CP / CP-G / DCP / DCP-G

ELECTRIC IN-LINE PUMPS

SELECTION TABLE - CP-G - 2 POLES

MODEL	Q=m ³ /h	0	6	12	18	24	30	36	42	48	54	60	66	72	78	84	90	102	114	120	150		
	Q=l/min	0	100	200	300	400	500	600	700	800	900	1000	1100	1200	1300	1400	1500	1700	1900	2000	2500		
CP-G 80-1400/A/BAQE/2.2	H (m)	14				13,8	13,3	12,9	12,5	12,1	11,4	10,8	10	9,2	8,3	7,5							
CP-G 80-1700/A/BAQE/3		17				16,5	16	15,5	15	14,5	13,7	13	12	11	10	9							
CP-G 80-2050/A/BAQE/4		20,5				20	19,5	19,1	18,5	18	17,5	16,5	15,8	14,8	14	12,5	11,5						
CP-G 80-2400/A/BAQE/5.5		24				23,6	23,5	23,2	22,8	22,2	21,5	21	20	19,1	18,5	17,5	16,5	13,4					
CP-G 80-2770/A/BAQE/7.5		27,7								27,5	27,3	27,1	26,7	25,8	25,6	24,9	24,5	23	21,2	20,1			
CP-G 80-3250/A/BAQE/11		32,5								32,2	32	31,8	31,3	30,2	30	29,2	28,7	27	24,8	23,6			
CP-G 80-4000/A/BAQE/15		40								40,2	40	39,8	39,5	39	38,5	38,2	37,5	36	34,5	33,5	26,9		
CP-G 80-5150/A/BAQE/18.5		51,5								52	52	51,5	50,5	50	49	48,5	47,5	45	42,5	41			
CP-G 80-5650/A/BAQE/22		56,5								58	58	57,5	57	56,5	56	55	54,5	53	51	49			
CP-G 80-6850/A/BAQE/30		68,5								70	70	70	68,5	69	68,8	68,5	67,5	66	64	63	57		
CP-G 80-8600/A/BAQE/37		86								83	82,5	82,5	82	81,5	81	80	79	76,5	73,5	72	60		
CP-G 80-9600/A/BAQE/45		96								92,5	92	92	91,5	91,5	91	90	89,5	87,5	85	83	72,5		
CP-G 80-10200/A/BAQE/55		102							101,6	101,5	101,3	101,1	100,7	100,3	99,7	99,1	98,3	97,4	95,4	92,9	91,5	83,2	

MODEL	Q= m ³ /h	0	36	42	48	54	60	66	72	78	84	90	102	114	120	150	180	210	240	270	300	330	360	390	420
	Q= l/min	0	600	700	800	900	1000	1100	1200	1300	1400	1500	1700	1900	2000	2500	3000	3500	4000	4500	5000	5500	6000	6500	7000
CP-G 100-1600/A/BAQE/4	H (m)	16	15	14,6	14,2	13,7	13,3	12,8	12,3	11,7	11	10	9,3	8											
CP-G 100-1950/A/BAQE/5.5		19,5	19	18,9	18,7	18,4	18,1	17,5	17,2	16,9	16,5	15,8	14,5	13	12										
CP-G 100-2350/A/BAQE/7.5		23,5	23,1	23	22,8	22,6	22,5	22	21,6	21,1	20,7	20,2	19	17,5	14,8	12									
CP-G 100-2400/A/BAQE/11		24										22	21,4	20,4	20	17,4	16,8	12							
CP-G 100-3050/A/BAQE/15		30,5										29	28,4	27,5	27	24,5	21,3	18,3							
CP-G 100-3550/A/BAQE/18.5		35,5										34,3	33,6	32,6	32,3	29,8	26,8	23,6	20						
CP-G 100-3850/A/BAQE/22		38,5										37,2	36,8	36	35,8	33,5	30,8	27,5	24						
CP-G 100-4800/A/BAQE/30		48										48,5	48,2	47,5	47	44,7	41	36	29						
CP-G 100-5600/A/BAQE/37		56										58	57,5	57,2	57	55	52	48	43						
CP-G 100-6300/A/BAQE/45		63										65,5	65	64	63	61,9	58,9	55,5	50,6	44,2					
CP-G 100-8300/A/BAQE/55		83										83,7	83,7	83,7	83,2	80,7	77,3	72,8	66,4	59,5					

MODEL	Q= m ³ /h	0	36	42	48	54	60	66	72	78	84	90	102	114	120	150	180	210	240	270	300	330	360	390	420
	Q= l/min	0	600	700	800	900	1000	1100	1200	1300	1400	1500	1700	1900	2000	2500	3000	3500	4000	4500	5000	5500	6000	6500	7000
CP-G 125-4750/A/BAQE/37	H (m)	46,5														45	44	42	39	37	34,5	31	28		
CP-G 125-5300/A/BAQE/45		51,5														51	50	48,5	46	44	42	39	35	31,5	
CP-G 125-5800/A/BAQE/55		57,5														57	56	55	53	51	49	46	43	39	36

CP / CP-G / DCP / DCP-G

ELECTRIC IN-LINE PUMPS

SELECTION TABLE - DPC - 2 POLES

MODEL	Q=m ³ /h	6	7,5	9	10,5	12	13,5	15	18	21	24	27	30	36	42	48	54	60	75	90	105	120	135		
	Q=l/min	100	125	150	175	200	225	250	300	400	450	500	600	700	800	800	900	1000	1250	1500	1750	2000	2250		
DCP 40/1250 T	H (m)	12,5	11,5	10,5	9,5	8,1	6,8	5,2																	
DCP 40/1650 T		16,5	15,5	14,5	13,5	12,3	11	9,5	6																
DCP 40/2050 T		20,5	20	19	18	17	16	15	11,5	7,5															
DCP 40/2450 T		24,5	24	23,5	23	22	21	20	16,5	13															

MODEL	Q=m ³ /h	6	7,5	9	10,5	12	13,5	15	18	21	24	27	30	36	42	48	54	60	75	90	105	120	135	
	Q=l/min	100	125	150	175	200	225	250	300	400	450	500	600	700	800	800	900	1000	1250	1500	1750	2000	2250	
DCP 50/1550 T	H (m)							15,5	15	14,1	13	11,8	10,5	7										
DCP 50/1900 T								19	18,5	17,5	16,5	15,5	14,5	10,5										
DCP 50/2450 T								24,5	24	23,5	23	22	20,5	17										
DCP 50/3000 T								30	29	28	26,5	25	23	18										
DCP 50/3650 T								36,5	35,5	34,5	33,5	32,5	31	27										

SELECTION TABLE - DPC-G - 2 POLES

MODEL	Q=m ³ /h	0	6	12	18	24	30	36	42	48	54	60	66	72	78	84	90	102	
	Q=l/min	0	100	200	300	400	500	600	700	800	900	1000	1100	1200	1300	1400	1500	1700	
DCP-G 65-1470/A/BAQE/1.5	H (m)	14,4	14,2	13,8	13,1	12,0	10,6	9,0	7,0	5,3									
DCP-G 65-1900/A/BAQE/2.2		18,6	18,3	17,8	16,9	15,7	14,2	12,5	10,5	8,3									
DCP-G 65-2280/A/BAQE/3		22,3			21,1	19,9	18,4	16,8	14,7	12,5	10,2								
DCP-G 65-2640/A/BAQE/4		25,9			24,6	23,7	22,2	20,7	18,8	16,4	14,0	11,4							
DCP-G 65-3400/A/BAQE/5.5		33,3			32,5	31,4	29,7	27,4	25,0	21,7	18,2								
DCP-G 65-4100/A/BAQE/7.5		40,2			39,6	39,0	37,4	35,7	33,4	30,7	27,5	23,9	20,1						
DCP-G 65-4700/A/BAQE/11		46,4					44,3	43,6	42,6	41,3	39,6	38,1	35,9	33,6	31,3				
DCP-G 65-5500/A/BAQE/15		54,3					54,7	53,9	52,1	51,2	49,4	48,0	45,6	43,7	41,3	38,4	36,1		
DCP-G 65-6150/A/BAQE/18.5		60,8					60,7	60,4	59,7	58,4	56,5	55,2	53,3	51,4	49,0	46,7	43,8	37,8	
DCP-G 65-7350/A/BAQE/22		72,6					73,4	72,6	71,6	70,9	68,0	65,1	63,2	60,7	57,8	54,9	51,5	43,1	
DCP-G 65-9250/A/BAQE/30		91,4					92,0	91,6	91,2	89,7	87,2	85,0	82,5	80,0	76,8	74,6	70,5	63,3	

CP / CP-G / DCP / DCP-G

ELECTRIC IN-LINE PUMPS

SELECTION TABLE - DCP-G - 2 POLES

MODEL	Q=m³/h	0	24	30	36	42	48	54	60	66	72	78	84	90	102	114	120	150
	Q=l/min	0	400	500	600	700	800	900	1000	1100	1200	1300	1400	1500	1700	1900	2000	2500
DCP-G 80-1400/A/BAQE/2.2	H (m)	13,7	14,3	13,7	13,0	12,3	11,4	10,3	9,1	7,8	6,5	5,2	4,0					
DCP-G 80-1700/A/BAQE/3		16,7	17,1	16,5	15,7	14,7	13,7	12,3	11,0	9,4	7,8	6,2	4,8					
DCP-G 80-2050/A/BAQE/4		20,1	20,8	20,1	19,5	18,4	17,4	16,2	14,6	13,1	11,3	9,7	7,7	6,1				
DCP-G 80-2400/A/BAQE/5.5		23,5	24,5	24,4	23,9	23,1	22,1	20,8	19,6	17,9	16,3	14,8	13,0	11,2	7,1			
DCP-G 80-2770/A/BAQE/7.5		27,1					26,6	26,0	25,3	24,3	22,8	21,9	20,5	19,3	16,2	13,0	11,3	
DCP-G 80-3250/A/BAQE/11		31,9					31,2	30,5	29,7	28,5	26,7	25,6	24,0	22,6	19,1	15,2	13,2	
DCP-G 80-4000/A/BAQE/15		39,2					39,7	39,1	38,5	37,7	36,7	35,6	34,6	33,2	30,1	26,9	25,1	15,1
DCP-G 80-5150/A/BAQE/18.5		48,3					48,9	48,6	47,7	46,3	45,3	43,8	42,7	41,1	37,4	33,6	31,5	
DCP-G 80-5650/A/BAQE/22		53,0					54,5	54,2	53,2	52,3	51,2	50,1	48,4	47,2	44,0	40,3	37,7	
DCP-G 80-6850/A/BAQE/30		64,3					66,3	66,1	65,8	64,1	64,1	63,5	62,7	61,2	58,5	55,2	53,5	43,8
DCP-G 80-8600/A/BAQE/37		86,4					85,3	84,9	85,1	84,7	84,3	83,8	82,9	81,9	79,3	76,2	74,6	61,8
DCP-G 80-9600/A/BAQE/45		96,4					95,1	94,7	94,9	94,5	94,6	94,2	93,2	92,8	90,7	88,1	86,0	74,7
DCP-G 80-10200/A/BAQE/55		102,4			103,9	104,1	104,1	104,1	103,9	103,6	103,1	102,6	101,8	101,0	98,9	96,3	94,8	85,7

MODEL	Q=m³/h	0	36	42	48	54	60	66	72	78	84	90	102	114	120	150	180	210	240	270	
	Q=l/min	0	600	700	800	900	1000	1100	1200	1300	1400	1500	1700	1900	2000	2500	3000	3500	4000	4500	
DCP-G 100-1600/A/BAQE/4	H (m)	16,0	15,8	15,2	14,5	13,6	12,8	11,8	10,8	9,6	8,4	7,3	5,1	3,0							
DCP-G 100-1950/A/BAQE/5.5		19,5	20,1	19,8	19,2	18,5	17,7	16,5	15,5	14,5	13,3	11,8	9,0	6,0	4,5						
DCP-G 100-2350/A/BAQE/7.5		23,5	24,5	24,4	24,0	23,6	23,1	22,2	21,4	20,4	19,4	18,3	15,7	12,9	11,7	4,5					
DCP-G 100-2400/A/BAQE/11		23,6											21,9	21,0	19,7	19,1	15,5	13,4	8,2		
DCP-G 100-3050/A/BAQE/15		30,0											28,9	27,9	26,5	25,8	21,8	17,0	12,5		
DCP-G 100-3550/A/AQE/18,5		34,9											34,6	33,5	32,1	31,6	27,8	23,3	18,5	13,7	
DCP-G 100-3850/A/BAQE/22		37,9											37,2	36,8	36,0	35,8	33,5	30,8	27,5	24,0	
DCP-G 100-4800/A/BAQE/30		52,7											52,1	51,6	50,7	50,0	47,1	42,7	37,0	29,3	
DCP-G 100-5600/A/BAQE/37		61,5											62,4	61,6	61,0	60,7	57,9	54,1	49,3	43,5	
DCP-G 100-6300/A/BAQE/45		68,1											70,1	69,3	67,9	66,7	62,7	57,1	49,5		
DCP-G 100-8300/A/BAQE/55		77,8											79,0	79,0	79,0	78,5	76,1	72,7	68,2	61,8	55,0

MODEL	Q=m³/h	0	150	180	210	240	270	300	330	360	390	420
	Q=l/min	0	2500	3000	3500	4000	4500	500	5500	6000	6500	7000
DCP-G 125-4750/A/BAQE/37	H (m)	45,0	44,2	42,0	39,0	36,0	31,0	26,4	20,0	17,1		
DCP-G 125-5300/A/BAQE/45		49,6	50,5	50,0	48,0	43,5	39,0	34,1	29,0	24,0	19,3	
DCP-G 125-5800/A/BAQE/55		55,7	56,7	56,0	52,0	50,0	46,0	41,7	39,0	32,0	28,0	22,0

CP 40 2 POLES- IN-LINE ELECTRIC PUMPS FOR HEATING, AIR CONDITIONING, REFRIGERATION, SOLAR, AND SANITARY SYSTEMS - SINGLE, FLANGED

Pumped liquid temperature range: from -10 °C to +130 °C - Maximum ambient temperature: +40 °C

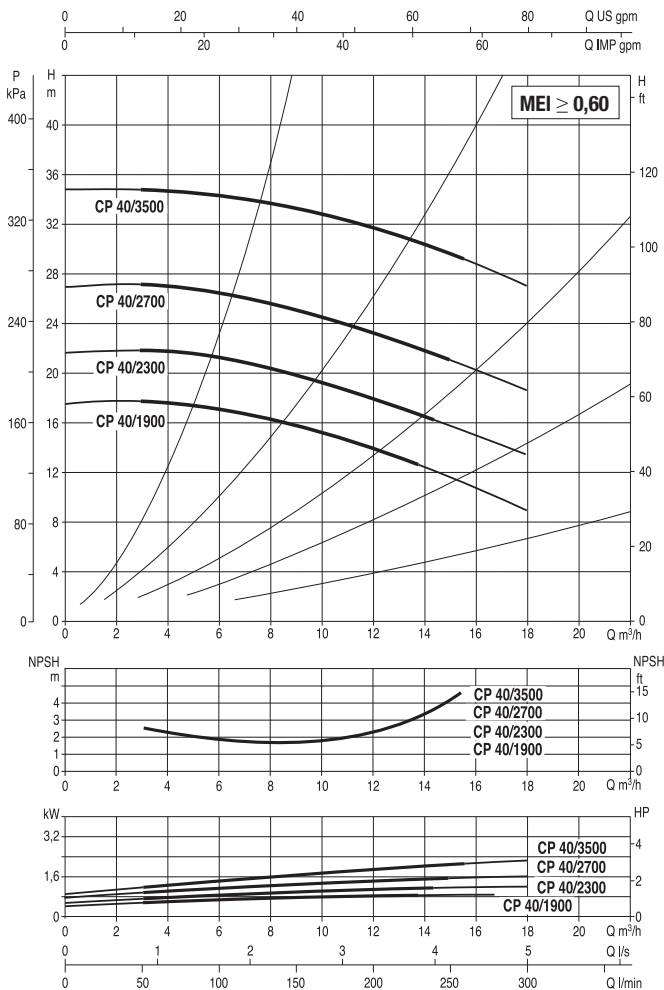
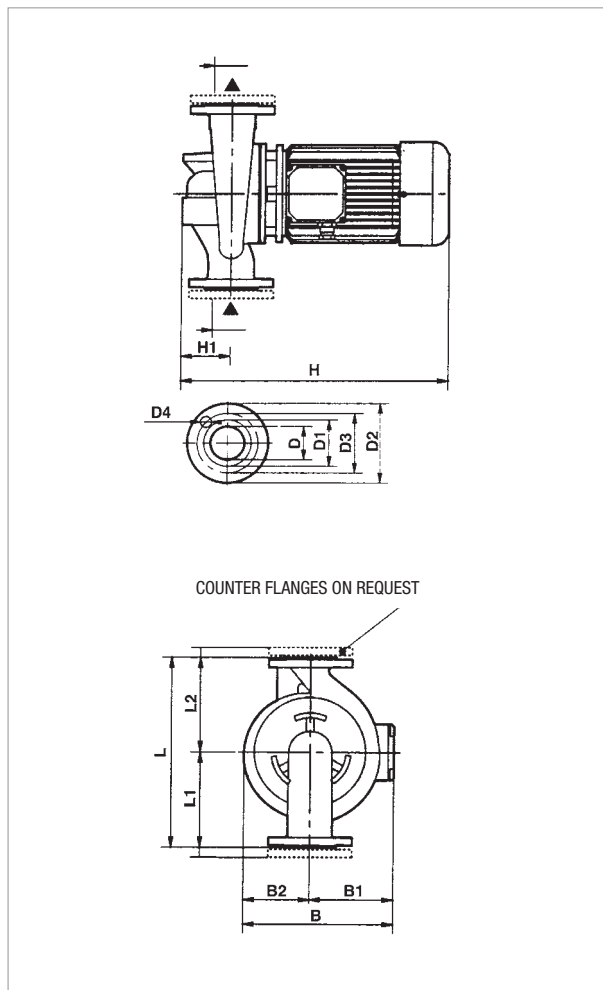

The performance curves are based on kinematic viscosity values = 1 mm²/s and density equal to 1000 kg/m³. Curve tolerance according to ISO 9906.

MODEL	CENTRE DISTANCE	PUMP CONNECTIONS	ELECTRICAL DATA									
			POWER INPUT 50 Hz	n r.p.m.	P1 MAX W	P2 NOMINAL		In A				MOTOR TYPE
						kW	HP	IE2		IE3		
CP 40/1900 T	390	DN 40	3 x 230 - 400 V ~	2910	1,1	0,75	1	5,4	3,1	-	-	IE2
CP 40/2300 T	390	DN 40	3 x 230 - 400 V ~	2870	1,45	1,1	1,5	5,9	3,4	-	-	IE2
CP 40/2700 T	390	DN 40	3 x 230 - 400 V ~	2850	1,89	1,5	2	7,1	4,1	-	-	IE2
CP 40/3500 T	390	DN 40	3 x 230 - 400 V ~	2880	2,53	2,21	3	8,9	5,1	-	-	IE2

MODEL	L	L1	L2	B	B1	B2	H		H1	D	D1	D2	D3	D4 no. of holes	PACKING DIMENSIONS			VOLUME (m ³)	WEIGHT kg	
							IE2	IE3							L/A	L/B	H		IE2	IE3
							CP 40/1900 T	390							200	190	231		118	113
CP 40/2300 T	390	200	190	231	118	113	453	-	95	40 PN 16	88	150	110	680	330	580	0,13	41	-	
CP 40/2700 T	390	200	190	231	118	113	453	-	95	40 PN 16	88	150	110	680	330	580	0,13	39	-	
CP 40/3500 T	390	200	190	231	118	113	453	-	95	40 PN 16	88	150	110	680	330	580	0,13	44	-	

CP 40 2 POLES- IN-LINE ELECTRIC PUMPS FOR HEATING, AIR CONDITIONING, REFRIGERATION, SOLAR, AND SANITARY SYSTEMS - SINGLE, FLANGED

Pumped liquid temperature range: from -10 °C to +130 °C - Maximum ambient temperature: +40 °C

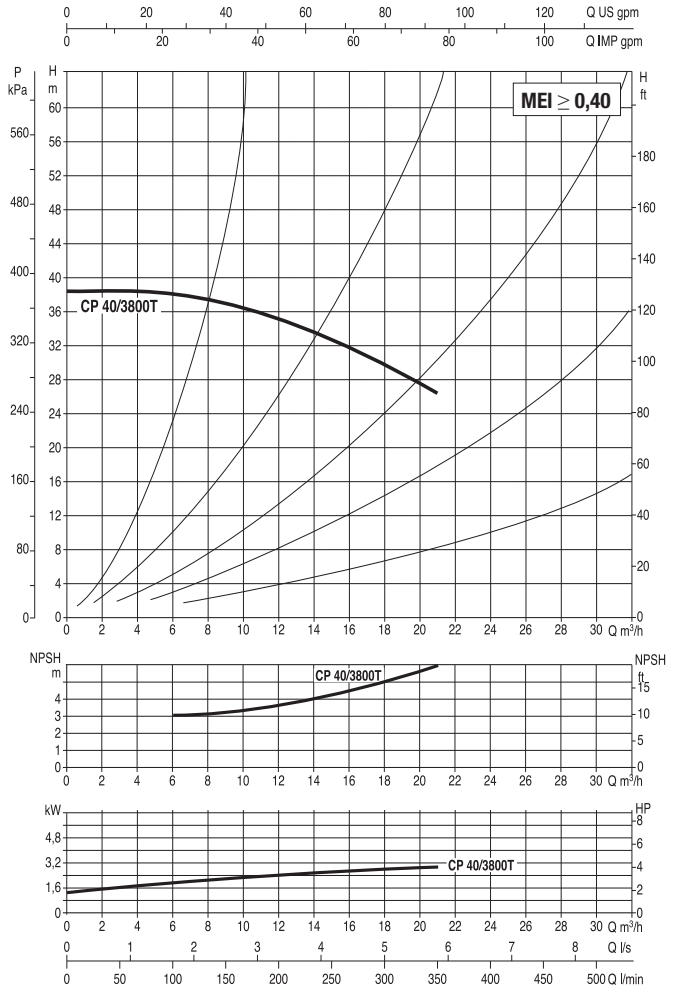
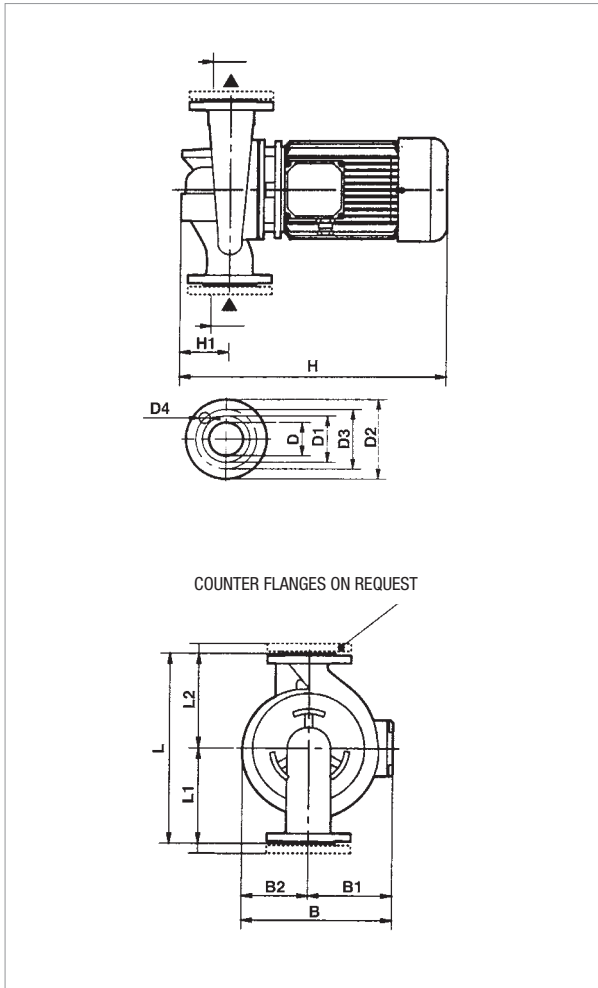

The performance curves are based on kinematic viscosity values = 1 mm²/s and density equal to 1000 kg/m³. Curve tolerance according to ISO 9906.

MODEL	CENTRE DISTANCE	PUMP CONNECTIONS	ELECTRICAL DATA									
			POWER INPUT 50 Hz	n r.p.m.	P1 MAX W	P2 NOMINAL		In A				MOTOR TYPE
						kW	HP	IE2		IE3		
CP 40/3800 T	380	DN 40	3 x 230 - 400 V ~	2900	3,54	3	4	10,2	5,9	-	-	IE2

MODEL	L	L1	L2	B	B1	B2	H		H1	D	D1	D2	D3	D4 no. of holes	PACKING DIMENSIONS			VOLUME (m ³)	WEIGHT kg	
							IE2	IE3							L/A	L/B	H		IE2	IE3
CP 40/3800 T	320	170	150	257	149	108	485	-	100	40 PN 6	88	150	110	4 ∅ 14	450	270	465	0,4	37	-

CP 40 2 POLES- IN-LINE ELECTRIC PUMPS FOR HEATING, AIR CONDITIONING, REFRIGERATION, SOLAR, AND SANITARY SYSTEMS - SINGLE, FLANGED

Pumped liquid temperature range: from -10 °C to +130 °C - Maximum ambient temperature: +40 °C

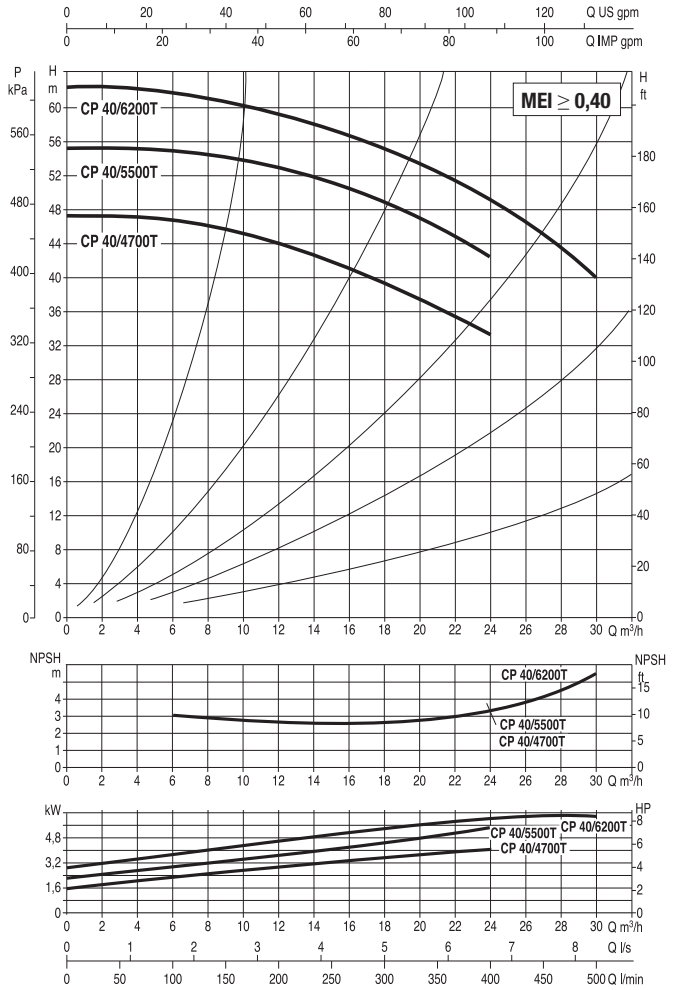
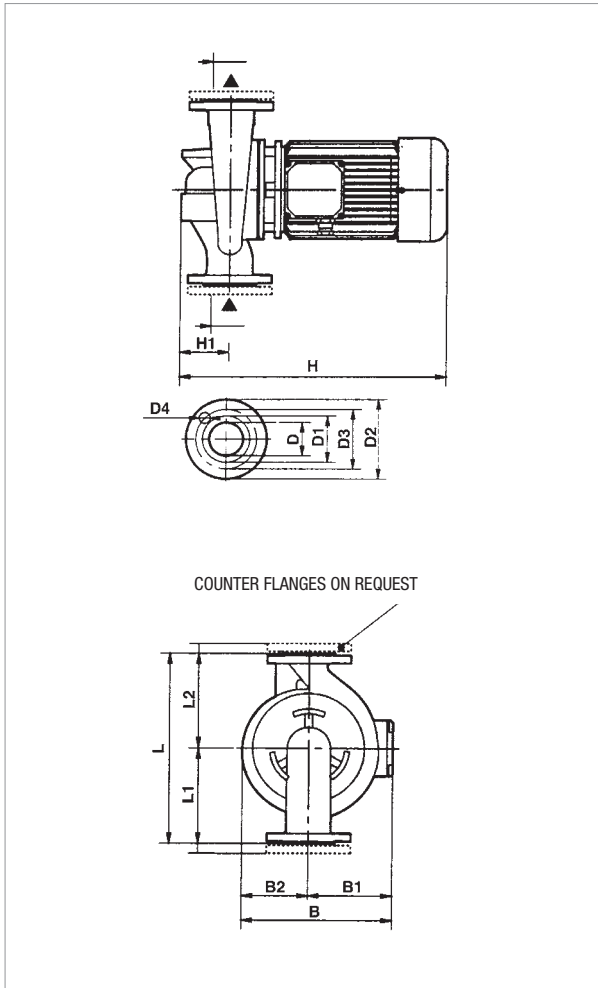

The performance curves are based on kinematic viscosity values = 1 mm²/s and density equal to 1000 kg/m³. Curve tolerance according to ISO 9906.

MODEL	CENTRE DISTANCE	PUMP CONNECTIONS	ELECTRICAL DATA									
			POWER INPUT 50 Hz	n r.p.m.	P1 MAX W	P2 NOMINAL		In A				MOTOR TYPE
						kW	HP	IE2		IE3		
CP 40/4700 T	380	DN 40	3 x 230 - 400 V ~	2900	4,87	4	5,5	13,5	7,8	-	-	IE2
CP 40/5500 T	425	DN 40	3 x 400 V ~ ¹	2900	6,57	5,5	7,5	-	10,6	-	-	IE2
CP 40/6200 T	425	DN 40	3 x 400 V ~ ¹	2900	9,18	7,5	10	-	14,2	-	14,4	IE2 / IE3

¹ star start-up possible (Δ)

MODEL	L	L1	L2	B	B1	B2	H		H1	D	D1	D2	D3	D4 no. of holes	PACKING DIMENSIONS			VOLUME (m ³)	WEIGHT kg	
							IE2	IE3							L/A	L/B	H		IE2	IE3
							CP 40/4700 T	380							200	180	286		159	127
CP 40/5500 T	380	200	180	286	159	127	535	-	100	40 PN 6	88	150	110	450	270	465	0,4	55	-	
CP 40/6200 T	380	200	180	286	159	127	535	535	100	40 PN 6	88	150	110	450	270	465	0,4	56	56	

CP 50 2 POLES- IN-LINE ELECTRIC PUMPS FOR HEATING, AIR CONDITIONING, REFRIGERATION, SOLAR, AND SANITARY SYSTEMS - SINGLE, FLANGED

Pumped liquid temperature range: from -10 °C to +140 °C - Maximum ambient temperature: +40 °C

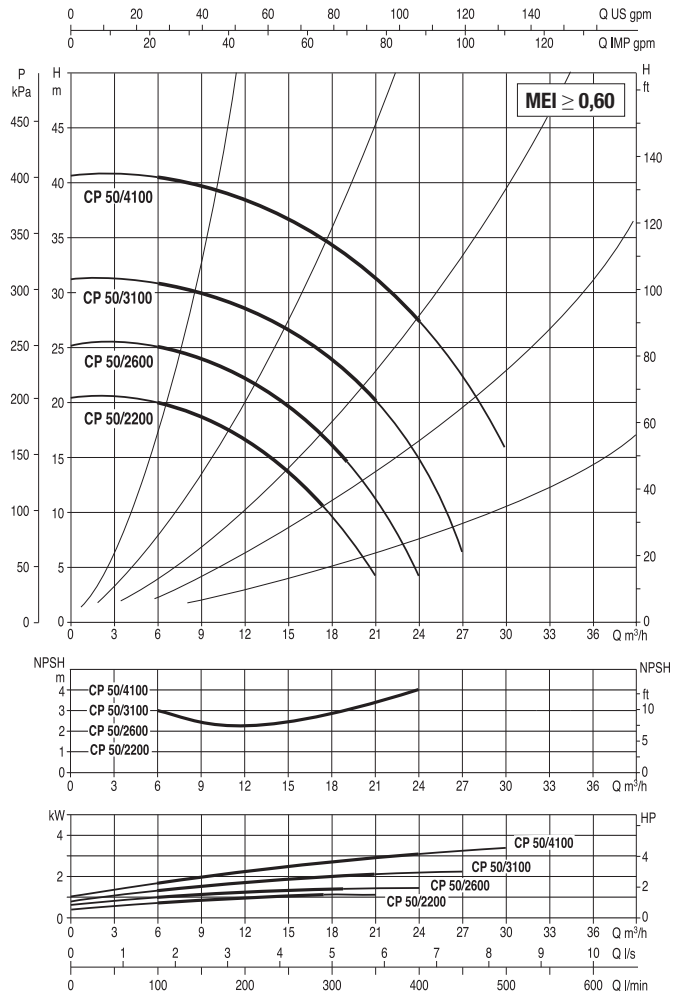
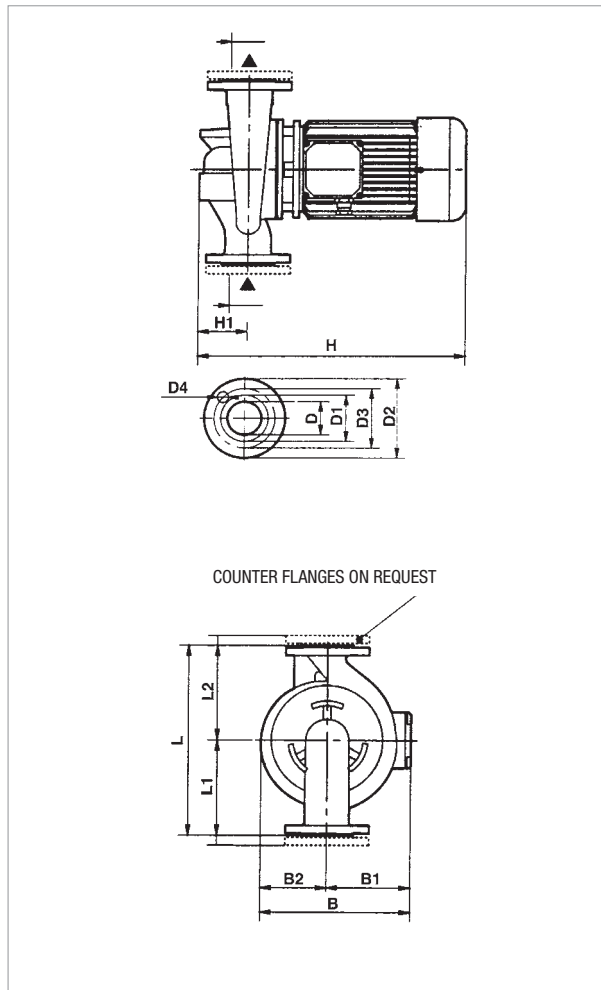

The performance curves are based on kinematic viscosity values = 1 mm²/s and density equal to 1000 kg/m³. Curve tolerance according to ISO 9906.

MODEL	CENTRE DISTANCE	PUMP CONNECTIONS	ELECTRICAL DATA									
			POWER INPUT 50 Hz	n r.p.m.	P1 MAX W	P2 NOMINAL		In A				MOTOR TYPE
						kW	HP	IE2		IE3		
CP 50/2200 T	425	DN 50	3 x 230 - 400 V ~	2870	1,42	1,1	1,5	5,8	3,4	-	-	IE2
CP 50/2600 T	425	DN 50	3 x 230 - 400 V ~	2860	1,89	1,5	2	6,9	4,0	-	-	IE2
CP 50/3100 T	400	DN 50	3 x 230 - 400 V ~	2870	2,51	2,2	3	8,7	5,0	-	-	IE2
CP 50/4100 T	400	DN 50	3 x 230 - 400 V ~	2910	3,8	4	5,5	11,6	6,7	-	-	IE2

MODEL	L	L1	L2	B	B1	B2	H		H1	D	D1	D2	D3	D4 no. of holes	PACKING DIMENSIONS			VOLUME (m ³)	WEIGHT kg	
							IE2	IE3							L/A	L/B	H		IE2	IE3
CP 50/2200 T	425	225	200	233	120	113	463	-	105	50 PN 16	102	165	125	4 Ø 18	680	330	580	0,13	40	-
CP 50/2600 T	425	225	200	233	120	113	463	-	105	50 PN 16	102	165	125		680	330	580	0,13	41	-
CP 50/3100 T	425	225	200	233	120	113	537	-	105	50 PN 16	102	165	125		680	330	580	0,13	46	-
CP 50/4100 T	425	225	200	233	120	113	537	-	105	50 PN 16	102	165	125		680	330	580	0,13	54	-

CP 50 2 POLES- IN-LINE ELECTRIC PUMPS FOR HEATING, AIR CONDITIONING, REFRIGERATION, SOLAR, AND SANITARY SYSTEMS - SINGLE, FLANGED

Pumped liquid temperature range: from -10 °C to +140 °C - Maximum ambient temperature: +40 °C

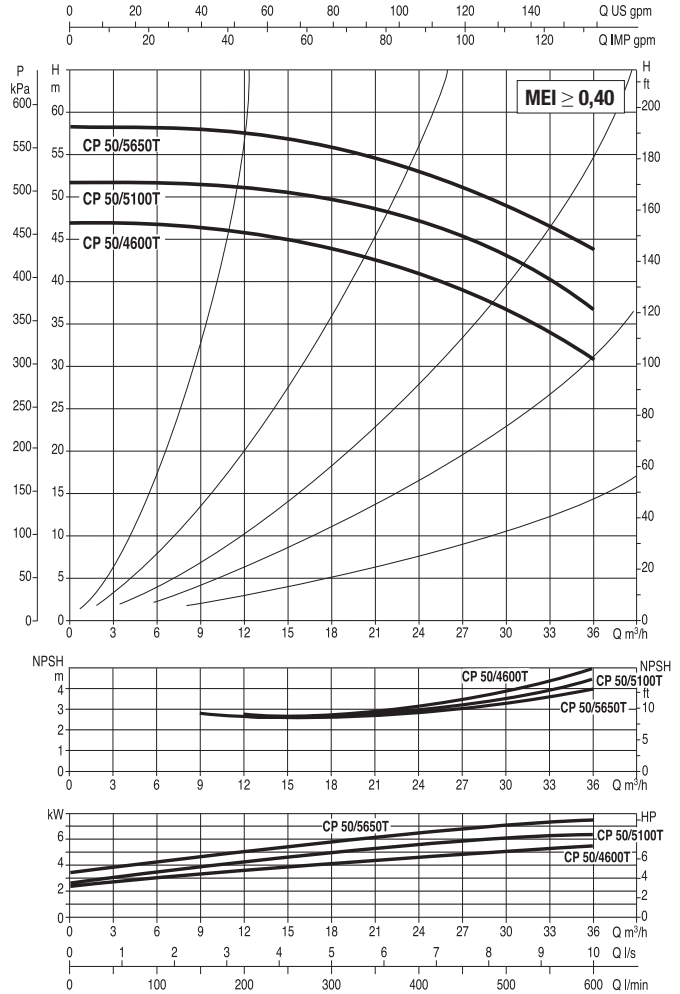
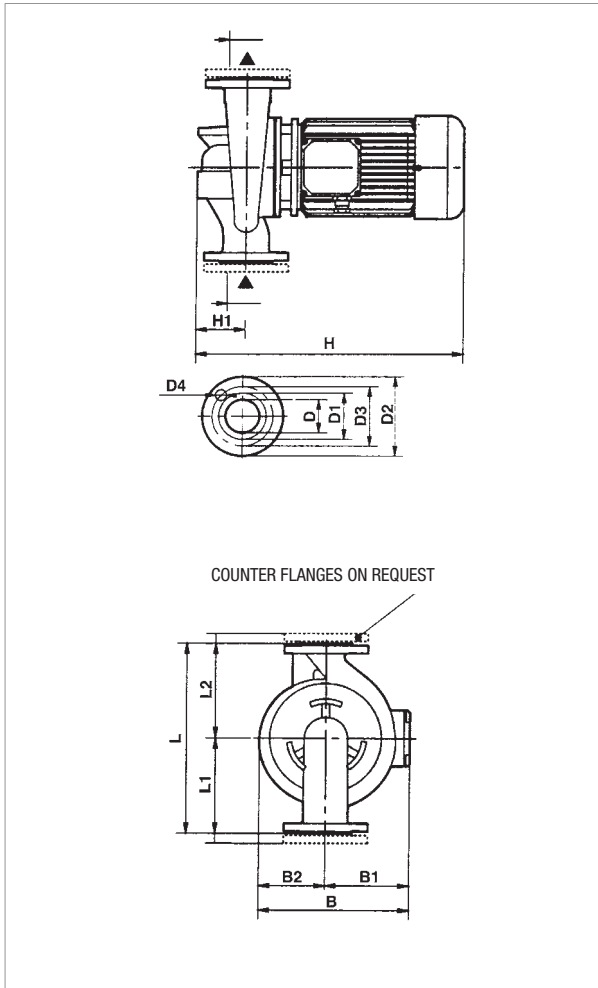

The performance curves are based on kinematic viscosity values = 1 mm²/s and density equal to 1000 kg/m³. Curve tolerance according to ISO 9906.

MODEL	CENTRE DISTANCE	PUMP CONNECTIONS	ELECTRICAL DATA							MOTOR TYPE
			POWER INPUT 50 Hz	n r.p.m.	P1 MAX W	P2 NOMINAL		In A		
						kW	HP	IE2	IE3	
CP 50/4600 T	360	DN 50	3 x 400 V ~ ¹	2900	6,57	5,5	7,5	10,6	-	IE2
CP 50/5100 T	360	DN 50	3 x 400 V ~ ¹	2900	9,18	7,5	10	14,2	14,4	IE2/IE3
CP 50/5650 T	360	DN 50	3 x 400 V ~ ¹	2900	9,18	7,5	10	14,2	14,4	IE2/IE3

¹ star start-up possible (Δ)

MODEL	L	L1	L2	B	B1	B2	H		H1	D	D1	D2	D3	D4 no. of holes	PACKING DIMENSIONS			VOLUME (m ³)	WEIGHT kg	
							IE2	IE3							L/A	L/B	H		IE2	IE3
CP 50/4600 T	400	220	180	290	159	131	545	-	110	50 PN 10	102	165	125	4 ∅ 18	520	320	535	0,6	56	-
CP 50/5100 T	400	220	180	290	159	131	545	545	110	50 PN 10	102	165	125		520	320	535	0,6	57	57
CP 50/5650 T	400	220	180	290	159	131	545	545	110	50 PN 10	102	165	125		520	320	535	0,6	64	64

CP-G 65 2 POLES- IN-LINE ELECTRIC PUMPS FOR HEATING, AIR CONDITIONING, REFRIGERATION, SOLAR, AND SANITARY SYSTEMS - SINGLE, FLANGED

Pumped liquid temperature range: from -10 °C to +140 °C - Maximum ambient temperature: +40 °C

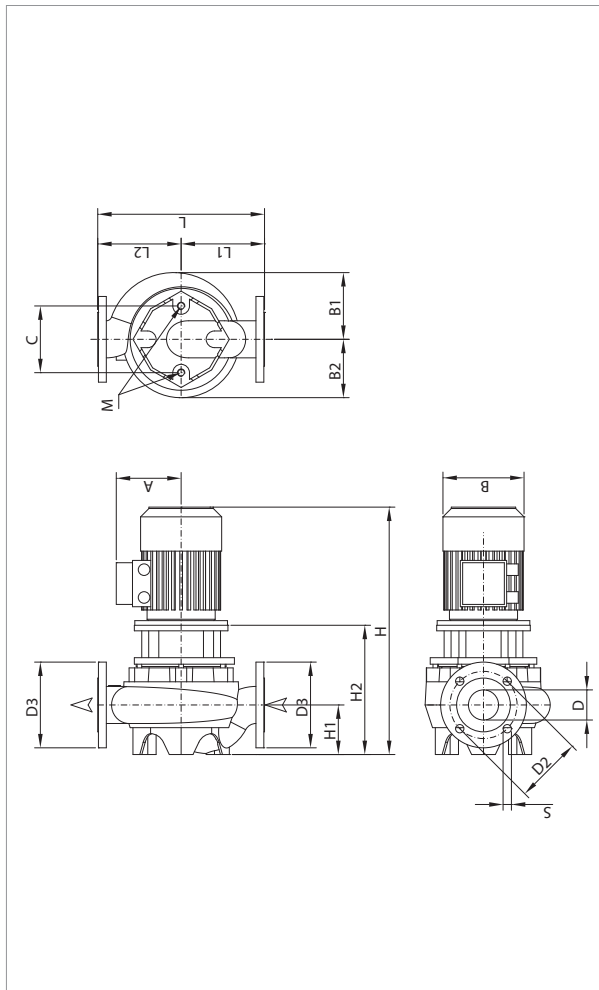

The performance curves are based on kinematic viscosity values = 1 mm²/s and density equal to 1000 kg/m³. Curve tolerance according to ISO 9906.

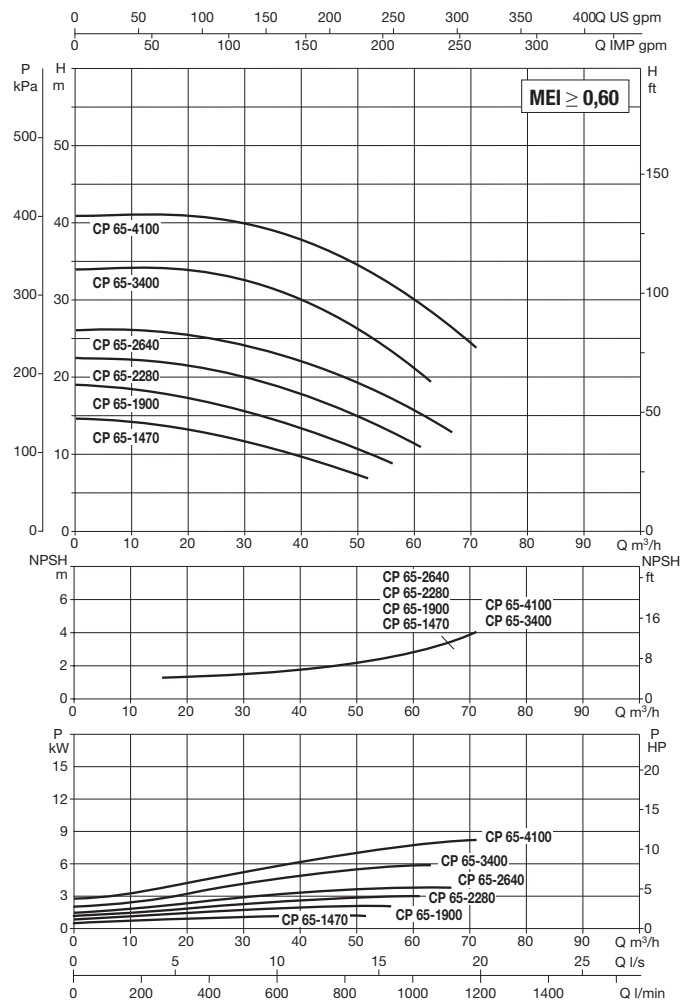

MODEL	CENTRE DISTANCE	PUMP CONNECTIONS	ELECTRICAL DATA												
			POWER INPUT 50 Hz	n r.p.m.	P1 MAX W	P2 NOMINAL		In A				MOTOR TYPE	MOTOR SIZE	I st. A	
						kW	HP	IE2	IE3	230	400			230	400
CP-G 65-1470/A/BAQE/1.5	360	DN 65	3x230-400 V ~	2883	1,9	1,50	2,00	5,8	3,3	-	-	IE2	MEC 90S	51,3/29,6	-
CP-G 65-1900/A/BAQE/2.2	360	DN 65	3x230-400 V ~	2872	3,1	2,20	3,00	8,2	4,7	-	-	IE2	MEC 90L	68,4/39,5	-
CP-G 65-2280/A/BAQE/3	360	DN 65	3 x 400 V ~ ¹	2882	3,4	3,00	4,00	5,8	-	-	-	IE2	MEC 100L	52,2	-
CP-G 65-2640/A/BAQE/4	360	DN 65	3 x 400 V ~ ¹	2910	4,7	4,00	5,50	8,0	-	-	-	IE2	MEC 112M	73,6	-
CP-G 65-3400/A/BAQE/5.5	360	DN 65	3 x 400 V ~ ¹	2913	6,6	5,50	7,50	10,4	-	-	-	IE2	MEC 132S	80,8	-
CP-G 65-4100/A/BAQE/7.5	360	DN 65	3 x 400 V ~ ¹	2900	8,6	7,50	10,00	14	-	13,4	-	IE2 / IE3	MEC 132S	106,7	113,9

¹ star start-up possible (A)

MODEL	A	B1	B2	C	D	D2	D3	S	no. of holes	H			L	L1	L2	M	PACKING DIMENSIONS			VOLUME (m ³)	WEIGHT kg		
										IE2	IE3	H1					H2	L/A	L/B		H	IE2	IE3
										CP-G 65-1470/A/BAQE/1.5	160	144					126	144	65		145	185	18
CP-G 65-1900/A/BAQE/2.2	160	144	126	144	65	145	185	18	4	614	-	107	279	360	180	180	M16	680	430	834	0,244	68	-
CP-G 65-2280/A/BAQE/3	180	144	126	144	65	145	185	18	4	632	-	107	307	360	180	180	M16	680	430	834	0,244	77	-
CP-G 65-2640/A/BAQE/4	190	144	126	144	65	145	185	18	4	717	-	107	307	360	180	180	M16	680	430	1084	0,317	92	-
CP-G 65-3400/A/BAQE/5.5	210	151	151	144	65	145	185	18	4	736	-	107	346	360	180	180	M16	680	430	1084	0,317	111	-
CP-G 65-4100/A/BAQE/7.5	188	151	151	144	65	145	185	18	4	736	783	107	346	360	180	180	M16	680	430	1084	0,317	111	87

CP-G 65 2 POLES- IN-LINE ELECTRIC PUMPS FOR HEATING, AIR CONDITIONING, REFRIGERATION, SOLAR, AND SANITARY SYSTEMS - SINGLE, FLANGED

Pumped liquid temperature range: from -10 °C to +140 °C - Maximum ambient temperature: +40 °C

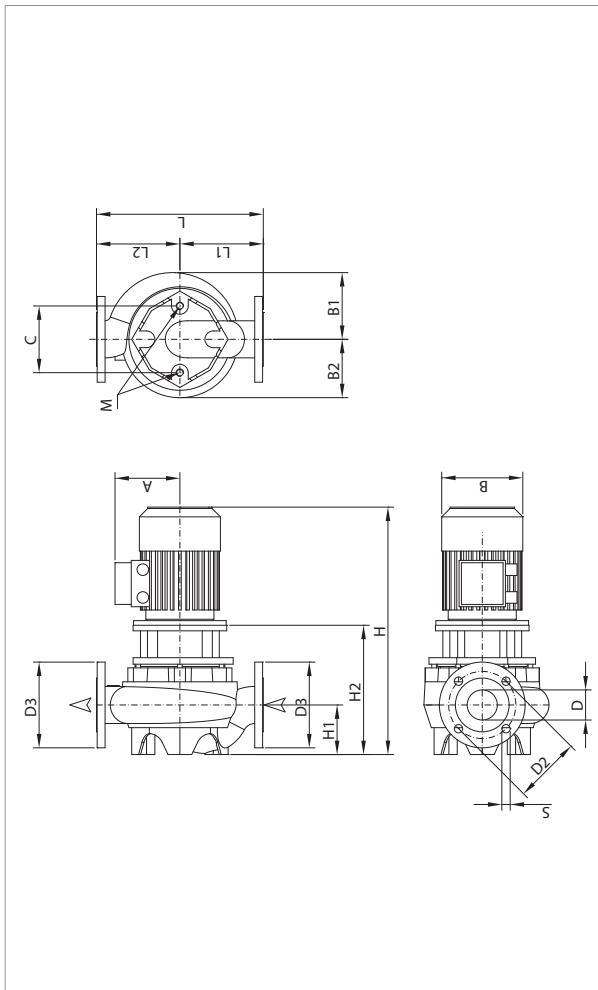

The performance curves are based on kinematic viscosity values = 1 mm²/s and density equal to 1000 kg/m³. Curve tolerance according to ISO 9906.

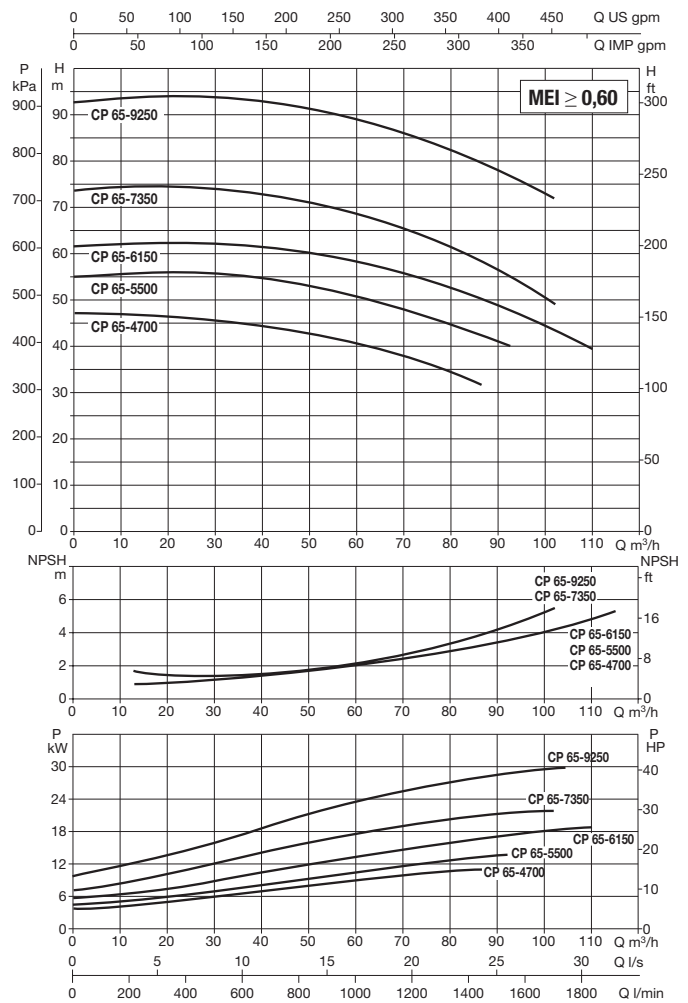

MODEL	CENTRE DISTANCE	PUMP CONNECTIONS	ELECTRICAL DATA										
			POWER INPUT 50 Hz	n r.p.m.	P1 MAX W	P2 NOMINAL		In A		MOTOR TYPE	MOTOR SIZE	I st. A	
						kW	HP	IE2	IE3			IE2	IE3
CP-G 65-4700/A/BAQE/11	475	DN 65	3 x 400 V ~ ¹	2940	14,1	11,00	15,00	20,2	19,4	IE2 / IE3	MEC 160M	126	147,4
CP-G 65-5500/A/BAQE/15	475	DN 65	3 x 400 V ~ ¹	2943	17,2	15,00	20,00	27	26,5	IE2 / IE3	MEC 160M	189,8	204
CP-G 65-6150/A/BAQE/18.5	475	DN 65	3 x 400 V ~ ¹	2947	21,8	18,50	25,00	33	32	IE2 / IE3	MEC 160L	239,9	262,4
CP-G 65-7350/A/BAQE/22	475	DN 65	3 x 400 V ~ ¹	2961	24,1	22,00	30,00	39,5	38	IE2 / IE3	MEC 180M	329	330,6
CP-G 65-9250/A/BAQE/30	475	DN 65	3 x 400 V ~ ¹	2950	32,5	30,00	40,00	52	52	IE2 / IE3	MEC 200L	405	468

¹ star start-up possible (Δ)

MODEL	A	B1	B2	C	D	D2	D3	S	no. of holes	H		H1	H2	L	L1	L2	M	PACKING DIMENSIONS			VOLUME (m ³)	WEIGHT kg	
										IE2	IE3							L/A	L/B	H		IE2	IE3
										CP-G 65-4700/A/BAQE/11	242							180	176	144		65	145
CP-G 65-5500/A/BAQE/15	242	180	176	144	65	145	185	18	893	893	215	388	475	237,5	237,5	M16	1200	720	720	0,622	221	194	
CP-G 65-6150/A/BAQE/18.5	242	180	176	144	65	145	185	18	948	937	215	388	475	237,5	237,5	M16	1200	720	720	0,622	229	198	
CP-G 65-7350/A/BAQE/22	260	190	190	144	65	145	185	18	968	968	215	388	475	237,5	237,5	M16	1200	720	720	0,622	272	232	
CP-G 65-9250/A/BAQE/30	292	210	210	144	65	145	185	18	1047,5	1058	215	388	475	237,5	237,5	M16	1200	720	720	0,622	309	310	

CP-G 80 2 POLES- IN-LINE ELECTRIC PUMPS FOR HEATING, AIR CONDITIONING, REFRIGERATION, SOLAR, AND SANITARY SYSTEMS - SINGLE, FLANGED

Pumped liquid temperature range: from -10 °C to +140 °C - Maximum ambient temperature: +40 °C

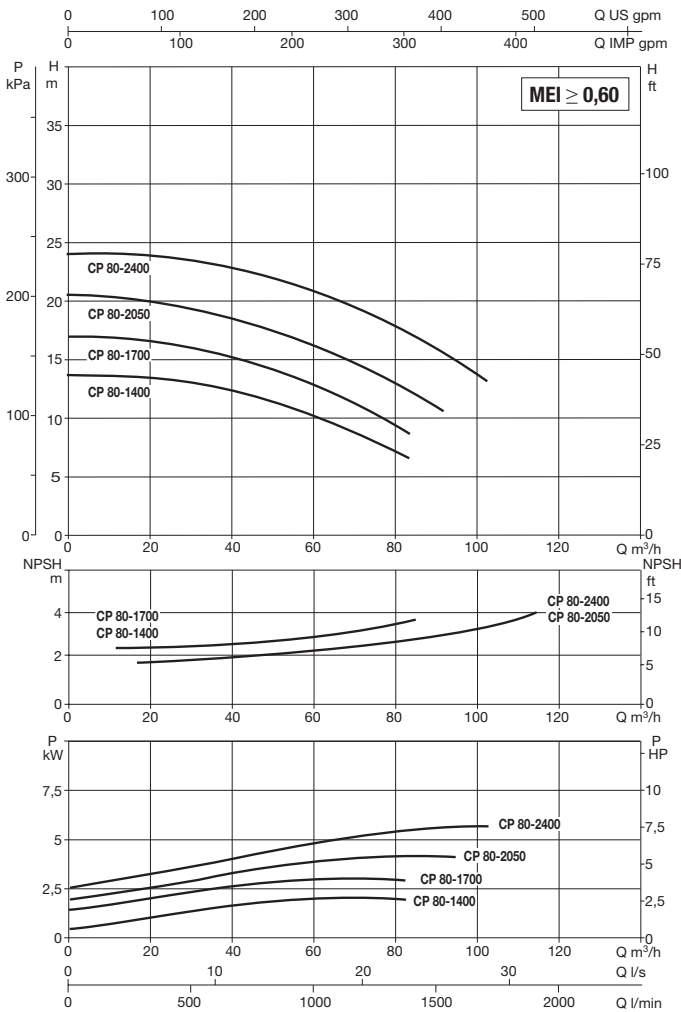
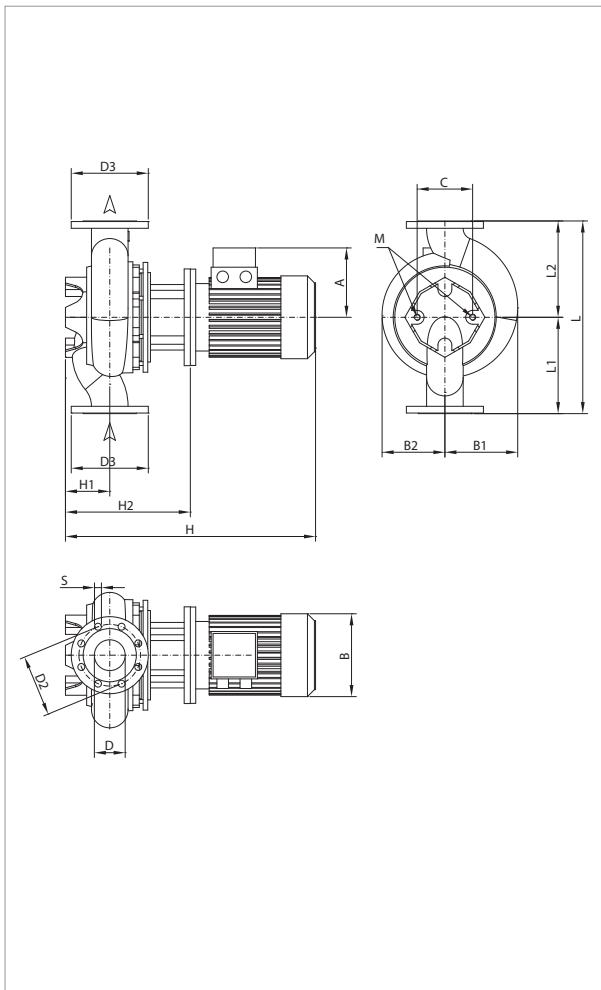

The performance curves are based on kinematic viscosity values = 1 mm²/s and density equal to 1000 kg/m³. Curve tolerance according to ISO 9906.

MODEL	CENTRE DISTANCE	PUMP CONNECTIONS	ELECTRICAL DATA												
			POWER INPUT 50 Hz	n r.p.m.	P1 MAX W	P2 NOMINAL		In A				MOTOR TYPE	MOTOR SIZE	I st. A	
						kW	HP	IE2	IE3	230	400			230	400
CP-G 80-1400/A/BAQE/2.2	360	DN 80	3x230-400 V ~	2874	3,0	2,20	3,00	8,2	4,7	-	-	IE2	MEC 90L	68,4/39,5	-
CP-G 80-1700/A/BAQE/3	360	DN 80	3 x 400 V ~ ¹	2880	3,5	3,00	4,00		5,8		-	IE2	MEC 100L	52,2	-
CP-G 80-2050/A/BAQE/4	360	DN 80	3 x 400 V ~ ¹	2914	5,0	4,00	5,50		8,0		-	IE2	MEC 112M	73,6	-
CP-G 80-2400/A/BAQE/5.5	360	DN 80	3 x 400 V ~ ¹	2910	6,4	5,50	7,50		10,4		-	IE2	MEC 132S	80,8	-

¹ star start-up possible (Δ)

MODEL	A	B1	B2	C	D	D2	D3	S	no. of holes	H						PACKING DIMENSIONS			VOLUME (m ³)	WEIGHT kg			
										IE2	IE3	H1	H2	L	L1	L2	M	L/A		L/B	H	IE2	IE3
CP-G 80-1400/A/BAQE/2.2	160	135	118	144	80	160	200	18	8	616	-	105	281	360	180	180	M16	680	430	834	0,244	71	-
CP-G 80-1700/A/BAQE/3	180	135	125	144	80	160	200	18		634	-	105	309	360	180	180	M16	680	430	834	0,244	80	-
CP-G 80-2050/A/BAQE/4	190	135	125	144	80	160	200	18		719	-	105	309	360	180	180	M16	680	430	1084	0,317	95	-
CP-G 80-2400/A/BAQE/5.5	210	135	151	144	80	160	200	18		738	-	105	348	360	180	180	M16	680	430	1084	0,317	114	-

CP-G 80 2 POLES- IN-LINE ELECTRIC PUMPS FOR HEATING, AIR CONDITIONING, REFRIGERATION, SOLAR, AND SANITARY SYSTEMS - SINGLE, FLANGED

Pumped liquid temperature range: from -10 °C to +140 °C - Maximum ambient temperature: +40 °C

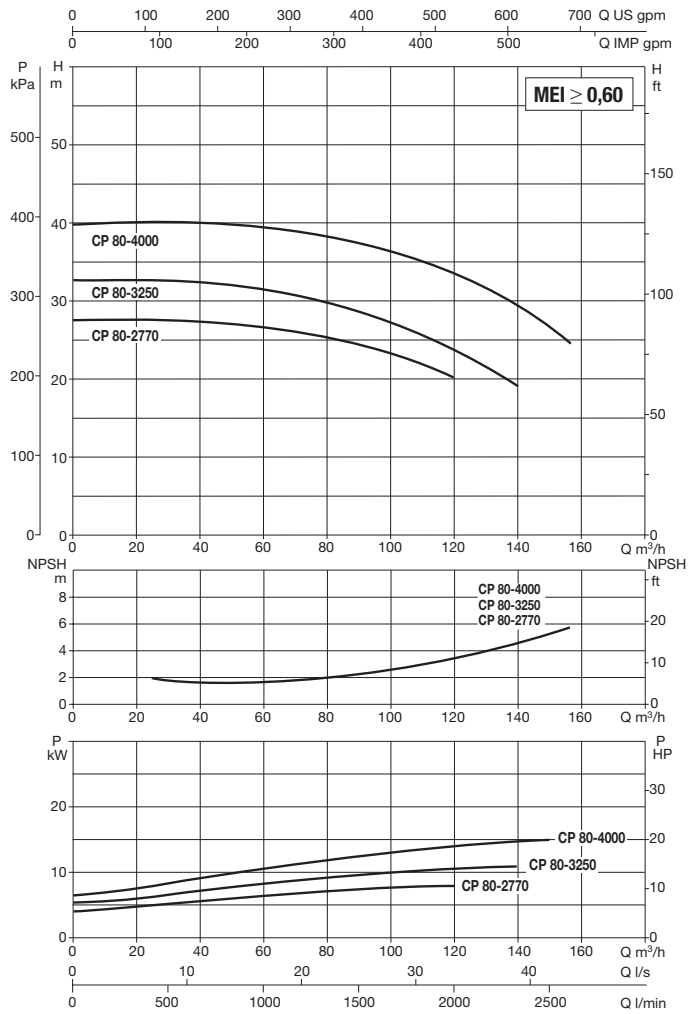
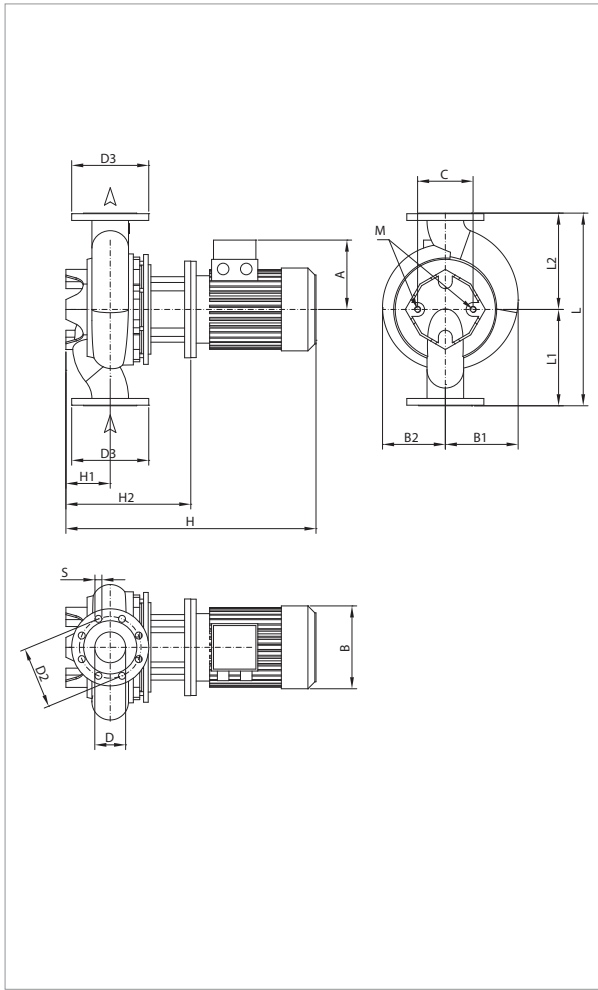

The performance curves are based on kinematic viscosity values = 1 mm²/s and density equal to 1000 kg/m³. Curve tolerance according to ISO 9906.

MODEL	CENTRE DISTANCE	PUMP CONNECTIONS	ELECTRICAL DATA										
			POWER INPUT 50 Hz	n r.p.m.	P1 MAX W	P2 NOMINAL		In A		MOTOR TYPE	MOTOR SIZE	I st. A	
						kW	HP	IE2	IE3			IE2	IE3
CP-G 80-2770/A/BAQE/7.5	440	DN 80	3 x 400 V ~ 1	2905	9,2	7,50	10,00	14	13,4	IE2 / IE3	MEC 132S	106,7	113,9
CP-G 80-3250/A/BAQE/11	440	DN 80	3 x 400 V ~ 1	2932	12,7	11,00	15,00	20,2	19,4	IE2 / IE3	MEC 160M	126	147,4
CP-G 80-4000/A/BAQE/15	440	DN 80	3 x 400 V ~ 1	2945	17,5	15,00	20,00	27	26,5	IE2 / IE3	MEC 160M	189,8	204

¹ star start-up possible (A)

MODEL	A	B1	B2	C	D	D2	D3	S	no. of holes	H		H1	H2	L	L1	L2	M	PACKING DIMENSIONS			VOLUME (m ³)	WEIGHT kg	
										IE2	IE3							L/A	L/B	H		IE2	IE3
										CP-G 80-2770/A/BAQE/7.5	188							178	151	144		80	160
CP-G 80-3250/A/BAQE/11	242	178	176	144	80	160	200	18	8	893	893	115	388	440	220	220	M16	1200	720	720	0,622	219	196
CP-G 80-4000/A/BAQE/15	242	178	176	144	80	160	200	18	8	893	893	115	388	440	220	220	M16	1200	720	720	0,622	194	167

CP-G 80 2 POLES- IN-LINE ELECTRIC PUMPS FOR HEATING, AIR CONDITIONING, REFRIGERATION, SOLAR, AND SANITARY SYSTEMS - SINGLE, FLANGED

Pumped liquid temperature range: from -10 °C to +140 °C - Maximum ambient temperature: +40 °C

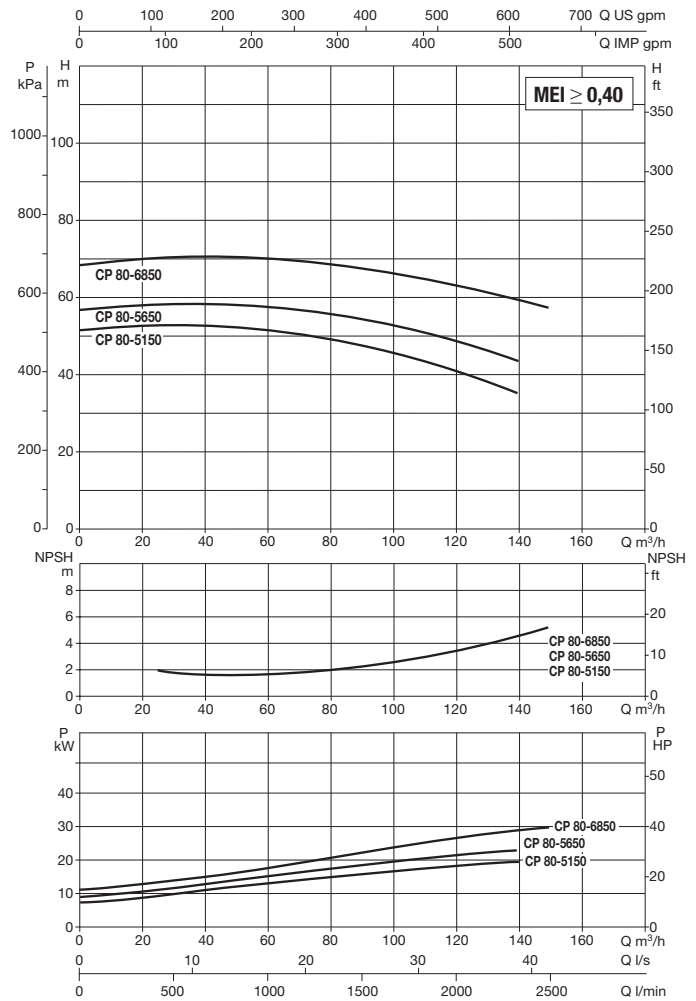
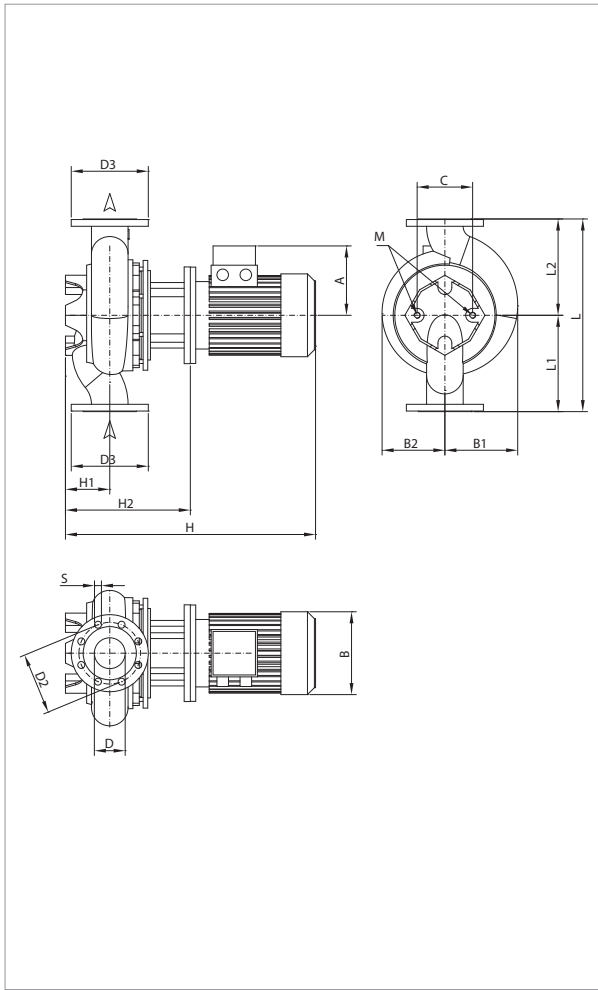

The performance curves are based on kinematic viscosity values = 1 mm²/s and density equal to 1000 kg/m³. Curve tolerance according to ISO 9906.

MODEL	CENTRE DISTANCE	PUMP CONNECTIONS	ELECTRICAL DATA										
			POWER INPUT 50 Hz	n r.p.m.	P1 MAX W	P2 NOMINAL		In A		MOTOR TYPE	MOTOR SIZE	I st. A	
						kW	HP	IE2	IE3			IE2	IE3
CP-G 80-5150/A/BAQE/18.5	500	DN 80	3 x 400 V ~ ¹	2943	21,0	18,50	25,00	33	32	IE2 / IE3	MEC 160L	239,9	262,4
CP-G 80-5650/A/BAQE/22	500	DN 80	3 x 400 V ~ ¹	2967	25,3	22,00	30,00	39,5	38	IE2 / IE3	MEC 180M	329	330,6
CP-G 80-6850/A/BAQE/30	500	DN 80	3 x 400 V ~ ¹	2951	32,8	30,00	40,00	52	52	IE2 / IE3	MEC 200L	405	468

¹ star start-up possible (Δ)

MODEL	A	B1	B2	C	D	D2	D3	S	no. of holes	H						M	PACKING DIMENSIONS			VOLUME (m ³)	WEIGHT kg		
										IE2	IE3	H1	H2	L	L1		L2	L/A	L/B		H	IE2	IE3
CP-G 80-5150/A/BAQE/18.5	242	178	176	144	80	160	200	18	8	948	937	115	388	440	220	220	M16	1200	720	720	0,622	152	121
CP-G 80-5650/A/BAQE/22	260	190	190	144	80	160	200	18		968	968	115	388	500	250	250	M16	1200	720	720	0,622	164	124
CP-G 80-6850/A/BAQE/30	292	210	210	144	80	160	200	18		1040	1050	115	380	500	250	250	M16	1200	720	720	0,622	313	314

CP-G 80 2 POLES- IN-LINE ELECTRIC PUMPS FOR HEATING, AIR CONDITIONING, REFRIGERATION, SOLAR, AND SANITARY SYSTEMS - SINGLE, FLANGED

Pumped liquid temperature range: from -10 °C to +140 °C - Maximum ambient temperature: +40 °C

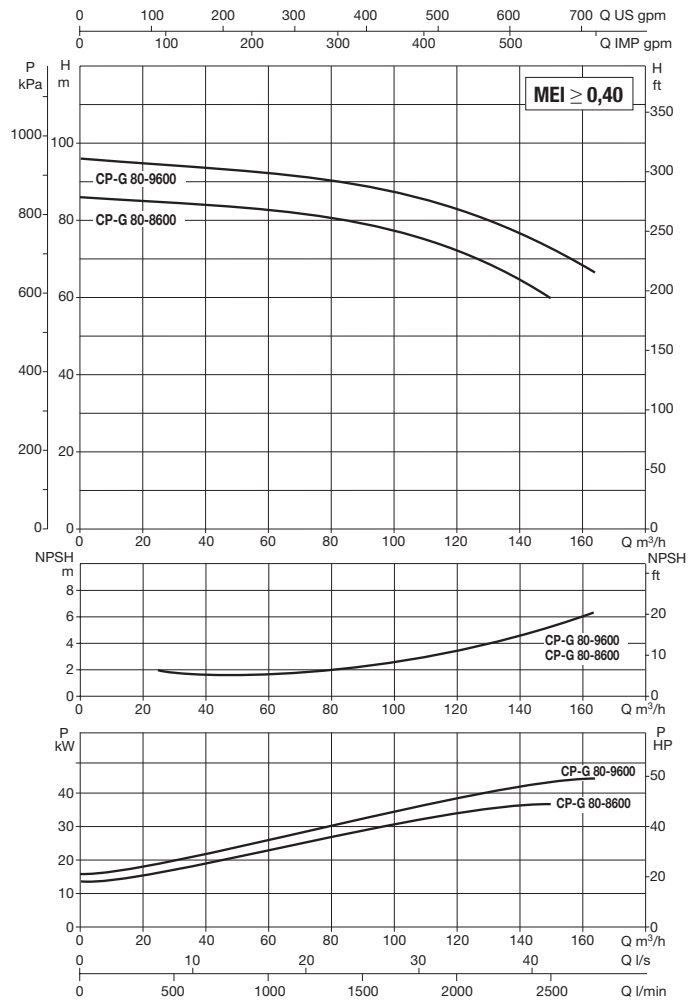
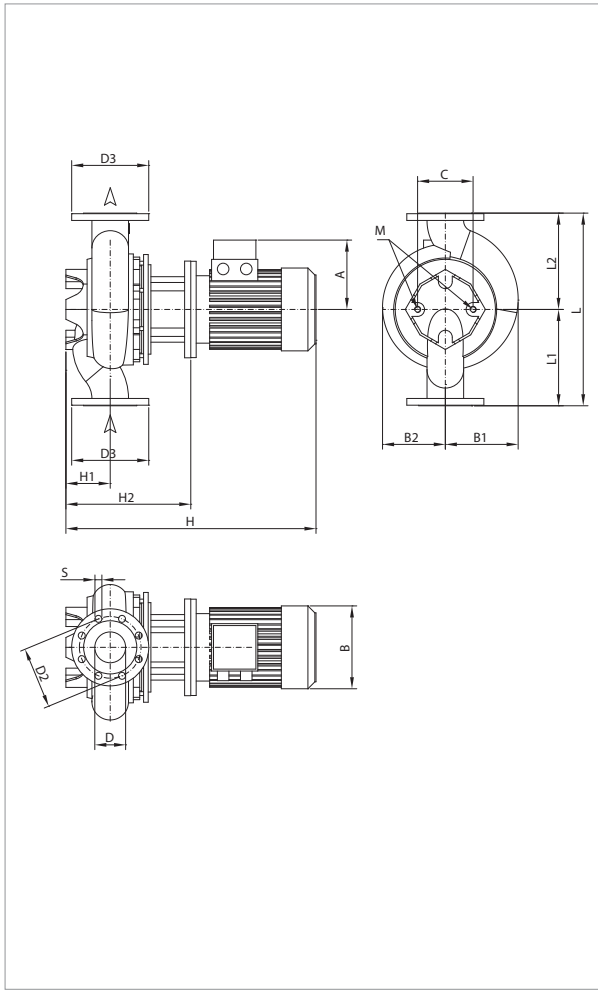

The performance curves are based on kinematic viscosity values = 1 mm²/s and density equal to 1000 kg/m³. Curve tolerance according to ISO 9906.

MODEL	CENTRE DISTANCE	PUMP CONNECTIONS	ELECTRICAL DATA										
			POWER INPUT 50 Hz	n r.p.m.	P1 MAX W	P2 NOMINAL		In A		MOTOR TYPE	MOTOR SIZE	I st. A	
						kW	HP	IE2	IE3			IE2	IE3
CP-G 80-8600/A/BAQE/37	620	DN 80	3 x 400 V ~ ¹	2967	41,9	37,00	50,00	64	63	IE2 / IE3	MEC 200L	487,7	567
CP-G 80-9600/A/BAQE/45	620	DN 80	3 x 400 V ~ ¹	2966	51,2	45,00	60,00	78,5	76	IE2 / IE3	MEC 225M	528,3	630,8

¹ star start-up possible (A)

MODEL	A	B1	B2	C	D	D2	D3	S	no. of holes	H						M	PACKING DIMENSIONS			VOLUME (m ³)	WEIGHT kg		
										IE2	IE3	H1	H2	L	L1		L2	L/A	L/B		H	IE2	IE3
CP-G 80-8600/A/BAQE/37	292	245	225	230	80	160	200	18	8	1103	1113	140	445	620	310	310	M16	1200	720	720	0,622	410	424
CP-G 80-9600/A/BAQE/45	315	245	232	230	80	160	200	18		1153	1158	140	445	620	310	310	M16	1200	720	720	0,622	318	347

CP-G 80 2 POLES- IN-LINE ELECTRIC PUMPS FOR HEATING, AIR CONDITIONING, REFRIGERATION, SOLAR, AND SANITARY SYSTEMS - SINGLE, FLANGED

Pumped liquid temperature range: from -10 °C to +140 °C - Maximum ambient temperature: +40 °C

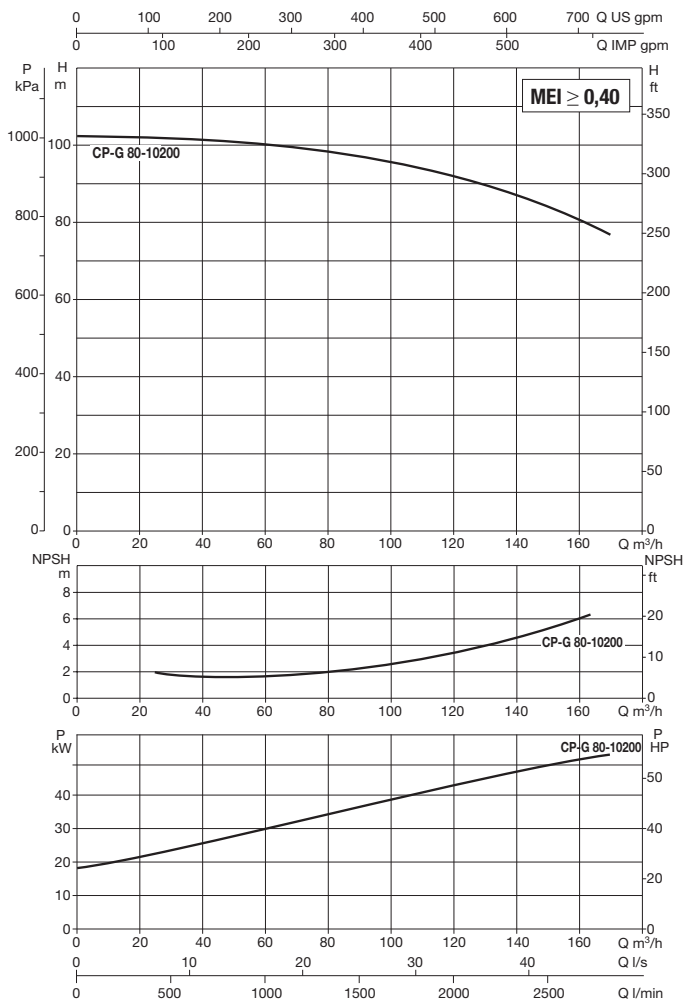
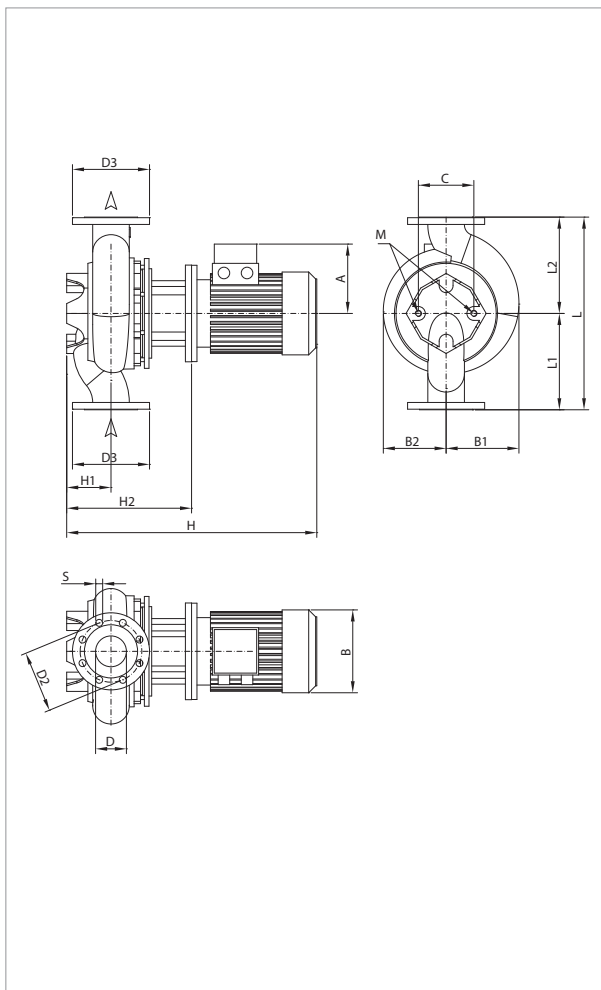

The performance curves are based on kinematic viscosity values = 1 mm²/s and density equal to 1000 kg/m³. Curve tolerance according to ISO 9906.

MODEL	CENTRE DISTANCE	PUMP CONNECTIONS	ELECTRICAL DATA										
			POWER INPUT 50 Hz	n r.p.m.	P1 MAX W	P2 NOMINAL		In A		MOTOR TYPE	MOTOR SIZE	I st. A	
						kW	HP	IE2	IE3			IE2	IE3
CP-G 80-10200/A/BAQE/55	620	DN 80	3 x 400 V ~ 1	2979	63,2	55,00	75,00	94	95	IE2 / IE3	MEC 250M	783	684

¹ star start-up possible (Δ)

MODEL	A	B1	B2	C	D	D2	D3	S	no. of holes	H		H1	H2	L	L1	L2	M	PACKING DIMENSIONS			VOLUME (m ³)	WEIGHT kg	
										IE2	IE3							L/A	L/B	H		IE2	IE3
CP-G 80-10200/A/BAQE/55	372	275	275	230	80	160	200	18	8	1248	1248	140	473	620	310	310	M16	2550	1300	1300	4,310	584	621

CP-G 100 2 POLES- IN-LINE ELECTRIC PUMPS FOR HEATING, AIR CONDITIONING, REFRIGERATION, SOLAR, AND SANITARY SYSTEMS - SINGLE, FLANGED

Pumped liquid temperature range: from -10 °C to +140 °C - Maximum ambient temperature: +40 °C

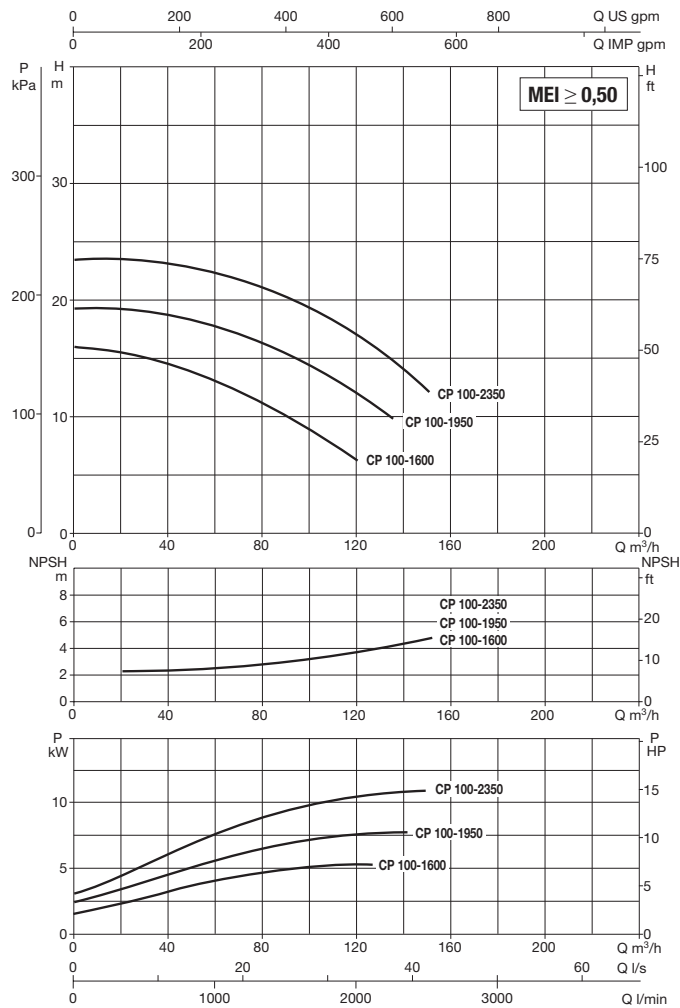
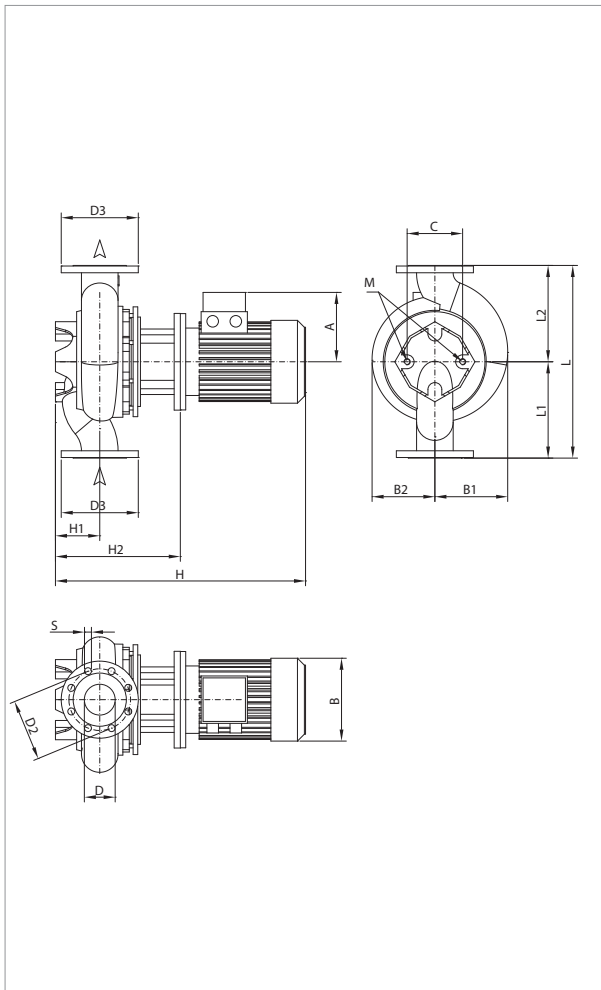

The performance curves are based on kinematic viscosity values = 1 mm²/s and density equal to 1000 kg/m³. Curve tolerance according to ISO 9906.

MODEL	CENTRE DISTANCE	PUMP CONNECTIONS	ELECTRICAL DATA										
			POWER INPUT 50 Hz	n r.p.m.	P1 MAX W	P2 NOMINAL		In A		MOTOR TYPE	MOTOR SIZE	I st. A	
						kW	HP	IE2	IE3			IE2	IE3
CP-G 100-1600/A/BAQE/4	500	DN 100	3 x 400 V ~ ¹	2918	5,3	4,00	5,50	8,0	-	IE2	MEC 112M	73,6	-
CP-G 100-1950/A/BAQE/5.5	500	DN 100	3 x 400 V ~ ¹	2918	7,0	5,50	7,50	10,4	-	IE2	MEC 132S	80,8	-
CP-G 100-2350/A/BAQE/7.5	500	DN 100	3 x 400 V ~ ¹	2906	9,2	7,50	10,00	14	13,4	IE2 / IE3	MEC 132S	106,7	113,9

¹ star start-up possible (A)

MODEL	A	B1	B2	C	D	D2	D3	S	no. of holes	H						M	PACKING DIMENSIONS			VOLUME (m ³)	WEIGHT kg		
										IE2	IE3	H1	H2	L	L1		L2	L/A	L/B		H	IE2	IE3
CP-G 100-1600/A/BAQE/4	190	156	126	144	100	180	220	18	8	686	-	140	346	500	250	250	M16	1200	720	720	0,622	88	-
CP-G 100-1950/A/BAQE/5.5	210	158	150	144	100	180	220	18		775	-	140	385	500	250	250	M16	1200	720	720	0,622	133	-
CP-G 100-2350/A/BAQE/7.5	188	158	150	144	100	180	220	18		775	822	140	385	500	250	250	M16	1200	720	720	0,622	113	89

CP-G 100 2 POLES- IN-LINE ELECTRIC PUMPS FOR HEATING, AIR CONDITIONING, REFRIGERATION, SOLAR, AND SANITARY SYSTEMS - SINGLE, FLANGED

Pumped liquid temperature range: from -10 °C to +140 °C - Maximum ambient temperature: +40 °C

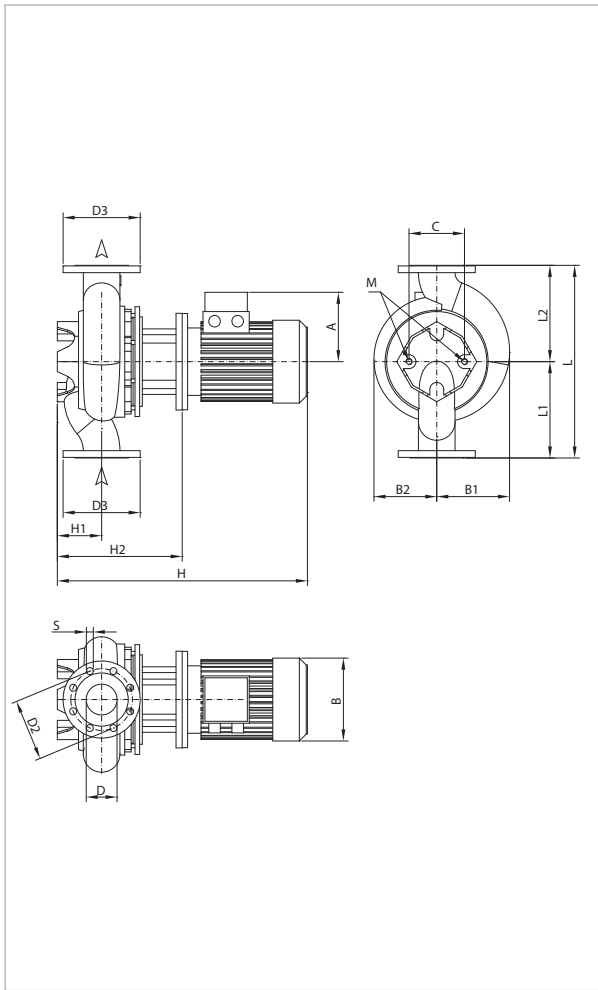

The performance curves are based on kinematic viscosity values = 1 mm²/s and density equal to 1000 kg/m³. Curve tolerance according to ISO 9906.

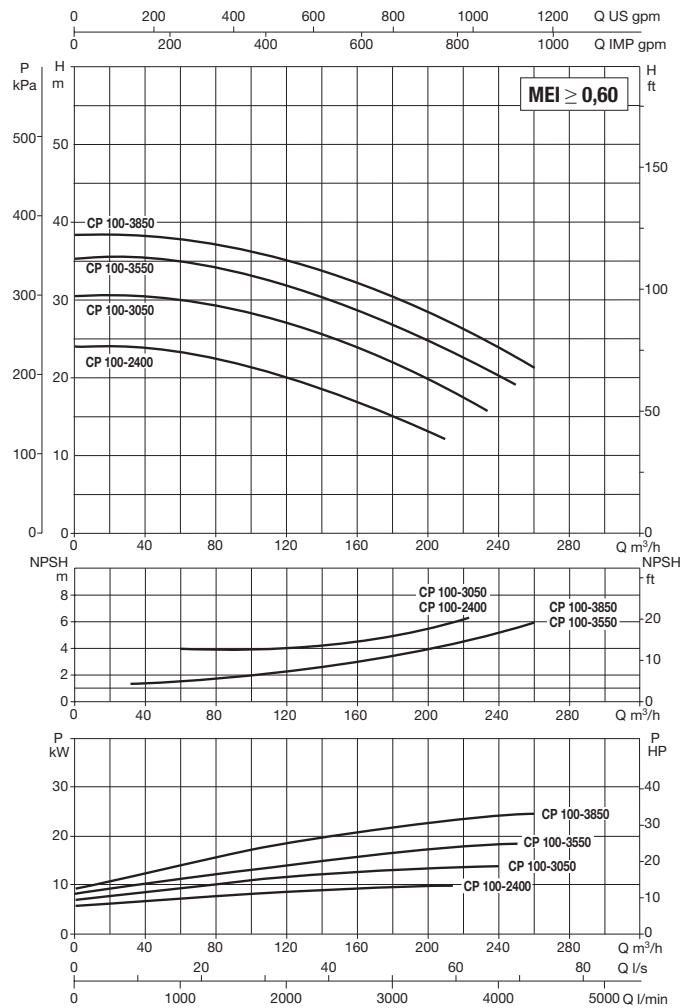

MODEL	CENTRE DISTANCE	PUMP CONNECTIONS	ELECTRICAL DATA										
			POWER INPUT 50 Hz	n r.p.m.	P1 MAX W	P2 NOMINAL		In A		MOTOR TYPE	MOTOR SIZE	I st. A	
						kW	HP	IE2	IE3			IE2	IE3
CP-G 100-2400/A/BAQE/11	550	DN 100	3 x 400 V ~ ¹	2940	13,9	11,00	15,00	20,2	19,4	IE2 / IE3	MEC 160M	126	147,4
CP-G 100-3050/A/BAQE/15	550	DN 100	3 x 400 V ~ ¹	2941	16,9	15,00	20,00	27	26,5	IE2 / IE3	MEC 160M	189,8	204
CP-G 100-3550/A/BAQE/18.5	550	DN 100	3 x 400 V ~ ¹	2948	21,9	18,50	25,00	33	32	IE2 / IE3	MEC 160L	239,9	262,4
CP-G 100-3850/A/BAQE/22	550	DN 100	3 x 400 V ~ ¹	2973	26,5	22,00	30,00	39,5	38	IE2 / IE3	MEC 180M	329	330,6

¹ star start-up possible (I)

MODEL	A	B1	B2	C	D	D2	D3	S	no. of holes	H						PACKING DIMENSIONS			VOLUME (m ³)	WEIGHT kg			
										IE2		H1	H2	L	L1	L2	M	L/A		L/B	H	IE2	IE3
										IE2	IE3												
CP-G 100-2400/A/BAQE/11	242	193	176	144	100	180	220	18	8	915	915	140	410	550	275	275	M16	1200	720	720	0,622	150	127
CP-G 100-3050/A/BAQE/15	242	193	176	144	100	180	220	18		915	915	140	410	550	275	275	M16	1200	720	720	0,622	177	150
CP-G 100-3550/A/BAQE/18.5	242	193	176	144	100	180	220	18		970	959	140	410	550	275	275	M16	1200	720	720	0,622	177	146
CP-G 100-3850/A/BAQE/22	260	192	190	230	100	180	220	18		990	990	140	410	550	275	275	M16	1200	720	720	0,622	299	259

CP-G 100 2 POLES- IN-LINE ELECTRIC PUMPS FOR HEATING, AIR CONDITIONING, REFRIGERATION, SOLAR, AND SANITARY SYSTEMS - SINGLE, FLANGED

Pumped liquid temperature range: from -10 °C to +140 °C - Maximum ambient temperature: +40 °C

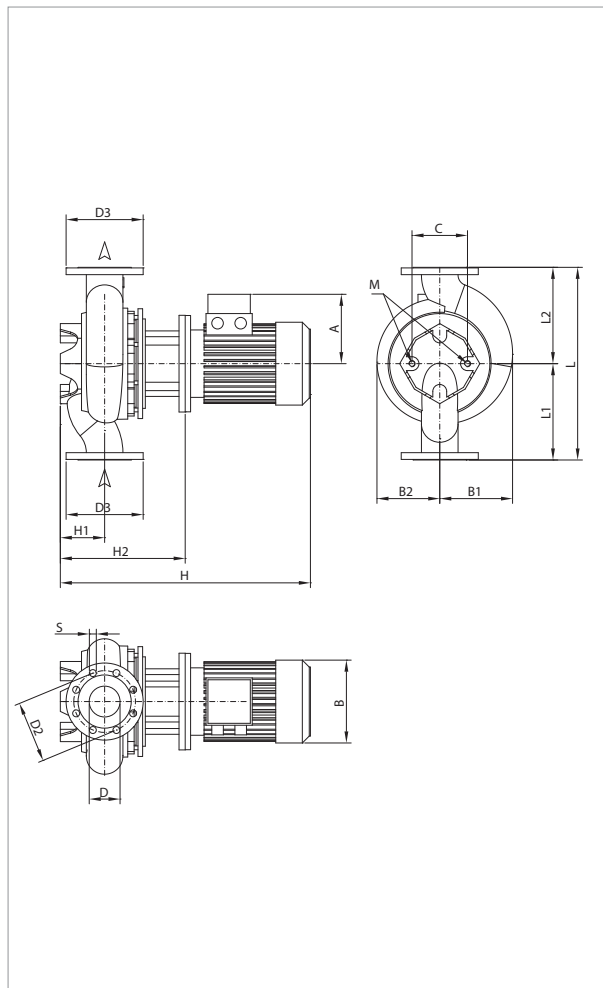

The performance curves are based on kinematic viscosity values = 1 mm²/s and density equal to 1000 kg/m³. Curve tolerance according to ISO 9906.

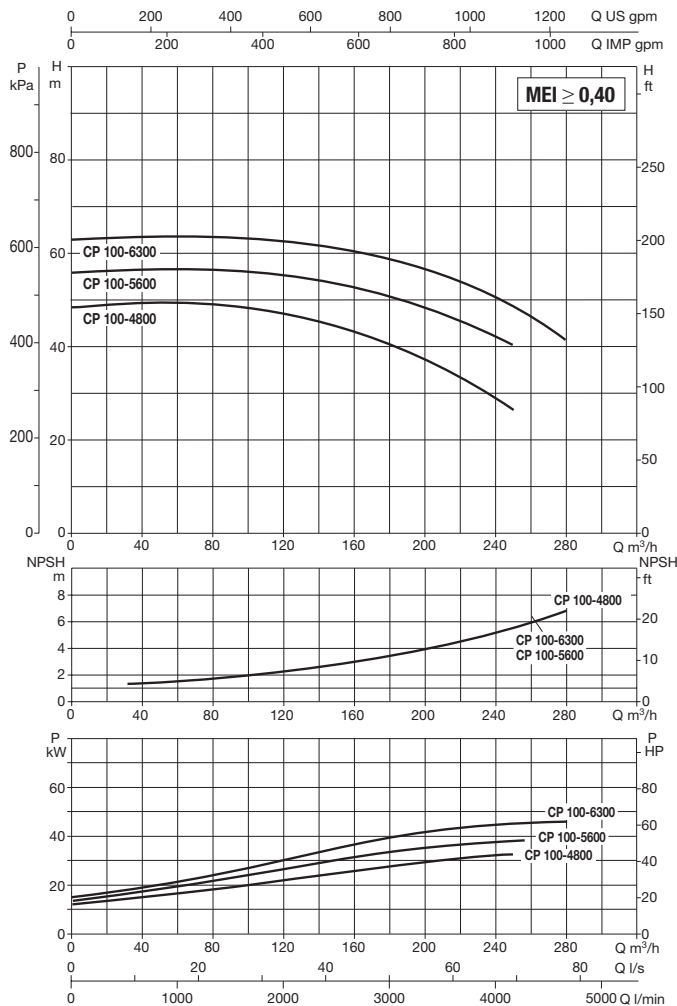

MODEL	CENTRE DISTANCE	PUMP CONNECTIONS	ELECTRICAL DATA										
			POWER INPUT 50 Hz	n.r.p.m.	P1 MAX W	P2 NOMINAL		In A		MOTOR TYPE	MOTOR SIZE	I st. A	
						kW	HP	IE2	IE3			IE2	IE3
CP-G 100-4800/A/BAQE/30	550	DN 100	3 x 400 V ~ ¹	2966	39,2	30,00	40,00	52	52	IE2 / IE3	MEC 200L	405	468
CP-G 100-5600/A/BAQE/37	550	DN 100	3 x 400 V ~ ¹	2975	45,0	37,00	50,00	64	63	IE2 / IE3	MEC 200L	487,7	567
CP-G 100-6300/A/BAQE/45	550	DN 100	3 x 400 V ~ ¹	2975	55,9	45,00	60,00	78,5	76	IE2 / IE3	MEC 225M	528,3	630,8

¹ star start-up possible (A)

MODEL	A	B1	B2	C	D	D2	D3	S	no. of holes	H			L	L1	L2	M	PACKING DIMENSIONS			VOLUME (m ³)	WEIGHT kg		
										IE2	IE3	H1					H2	L/A	L/B		H	IE2	IE3
CP-G 100-4800/A/BAQE/30	292	210	210	230	100	180	220	18	8	1107	1117	140	447	550	275	275	M16	1200	720	720	0,622	336	337
CP-G 100-5600/A/BAQE/37	292	210	210	230	100	180	220	18		1107	1117	140	447	550	275	275	M16	1200	720	720	0,622	383	397
CP-G 100-6300/A/BAQE/45	315	235	235	230	100	180	220	18		1157	1162	140	447	550	275	275	M16	1200	720	720	0,622	441	470

CP-G 100 2 POLES- IN-LINE ELECTRIC PUMPS FOR HEATING, AIR CONDITIONING, REFRIGERATION, SOLAR, AND SANITARY SYSTEMS - SINGLE, FLANGED

Pumped liquid temperature range: from -10 °C to +140 °C - Maximum ambient temperature: +40 °C

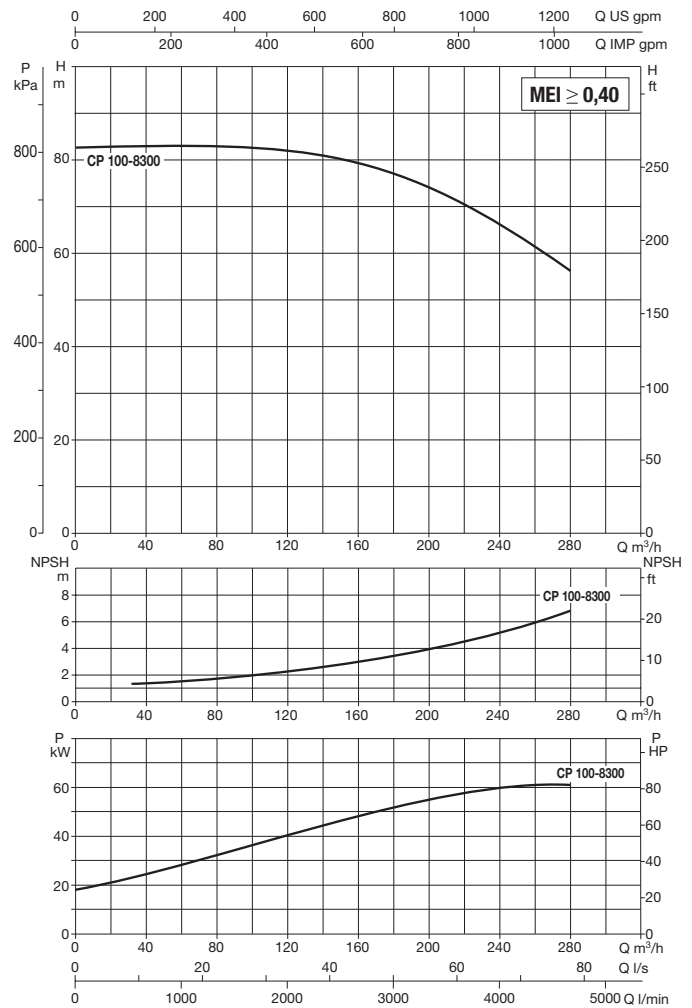
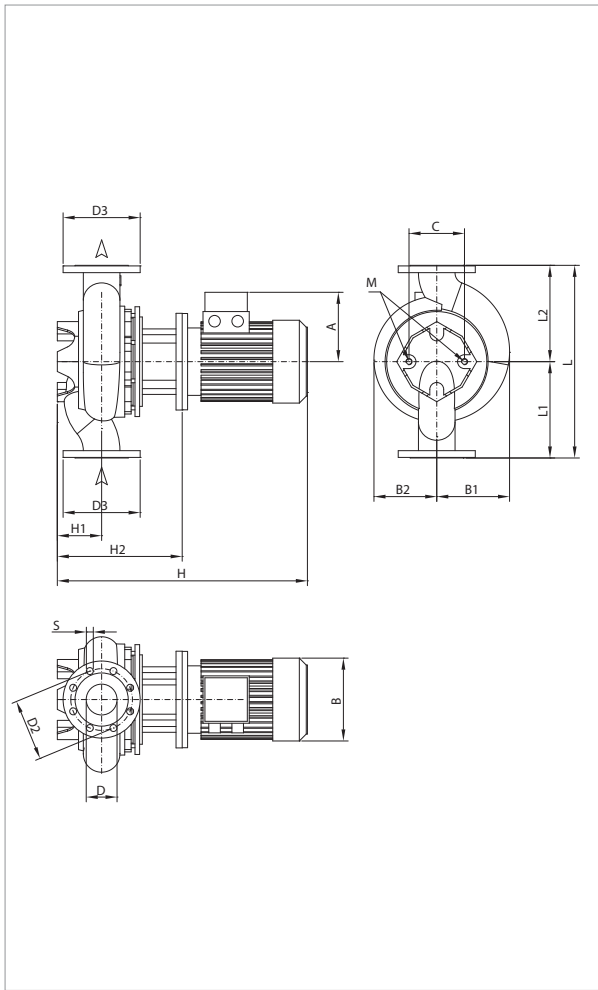

The performance curves are based on kinematic viscosity values = 1 mm²/s and density equal to 1000 kg/m³. Curve tolerance according to ISO 9906.

MODEL	CENTRE DISTANCE	PUMP CONNECTIONS	ELECTRICAL DATA										
			POWER INPUT 50 Hz	n r.p.m.	P1 MAX W	P2 NOMINAL		In A		MOTOR TYPE	MOTOR SIZE	I st. A	
						kW	HP	IE2	IE3			IE2	IE3
CP-G 100-8300/A/BAQE/55	670	DN 100	3 x 400 V ~ ¹	2981	70,1	55,00	75,00	94	95	IE2 / IE3	MEC 250M	783	684

¹ star start-up possible (Δ)

MODEL	A	B1	B2	C	D	D2	D3	S	no. of holes	H		H1	H2	L	L1	L2	M	PACKING DIMENSIONS			VOLUME (m ³)	WEIGHT kg	
										IE2	IE3							L/A	L/B	H		IE2	IE3
CP-G 100-8300/A/BAQE/55	372	293	275	230	100	180	220	18	8	1288	1288	175	513	670	335	335	M16	1500	760	725	0,827	590	627

CP-G 125 2 POLES- IN-LINE ELECTRIC PUMPS FOR HEATING, AIR CONDITIONING, REFRIGERATION, SOLAR, AND SANITARY SYSTEMS - SINGLE, FLANGED

Pumped liquid temperature range: from -10 °C to +140 °C - Maximum ambient temperature: +40 °C

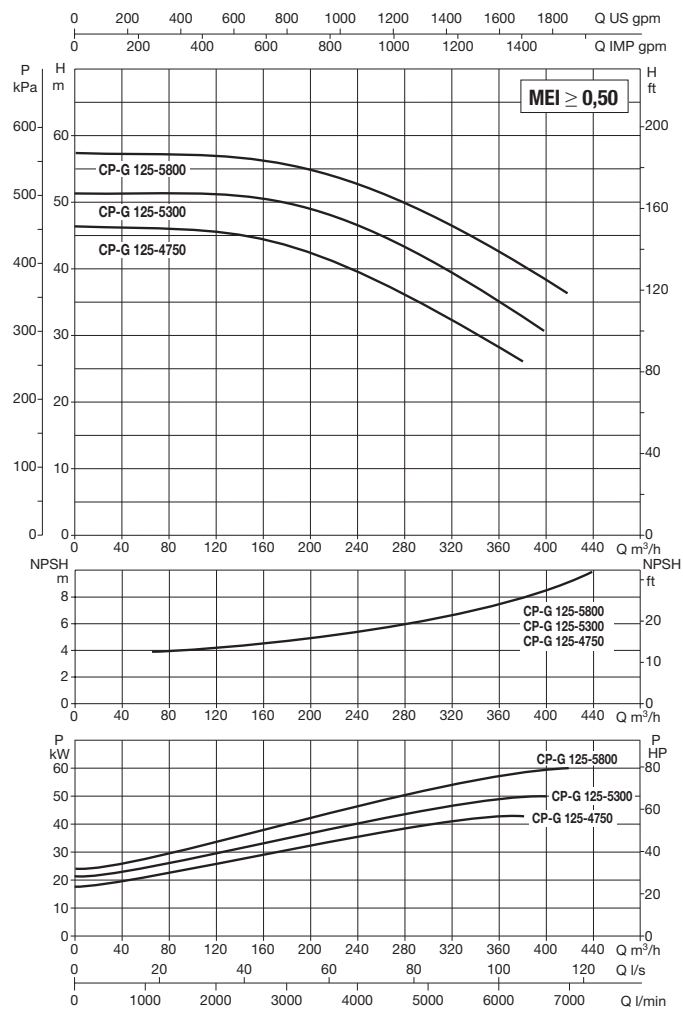
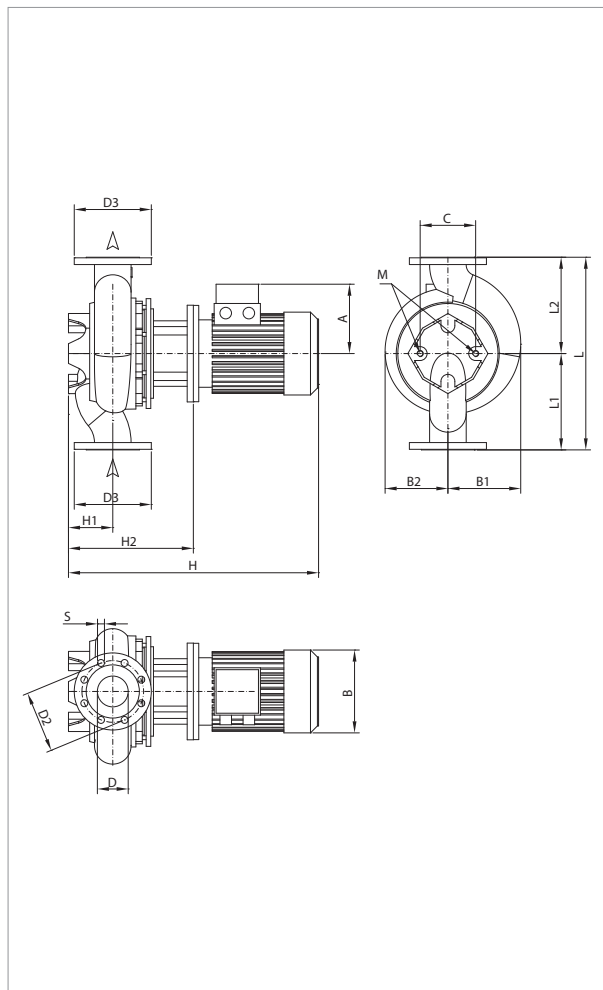

The performance curves are based on kinematic viscosity values = 1 mm²/s and density equal to 1000 kg/m³. Curve tolerance according to ISO 9906.

MODEL	CENTRE DISTANCE	PUMP CONNECTIONS	ELECTRICAL DATA										
			POWER INPUT 50 Hz	n r.p.m.	P1 MAX W	P2 NOMINAL		In A		MOTOR TYPE	MOTOR SIZE	I st. A	
						kW	HP	IE2	IE3			IE2	IE3
CP-G 125-4750/A/BAQE/37	620	DN 125	3 x 400 V ~ ¹	2975	44,7	37,00	50,00	64	63	IE2 / IE3	MEC 200L	487,7	567
CP-G 125-5300/A/BAQE/45	620	DN 125	3 x 400 V ~ ¹	2973	53,9	45,00	60,00	78,5	76	IE2 / IE3	MEC 225M	528,3	630,8
CP-G 125-5800/A/BAQE/55	620	DN 125	3 x 400 V ~ ¹	2985	68,2	55,00	75,00	94	95	IE2 / IE3	MEC 250M	783	684

¹ star start-up possible (Δ)

MODEL	A	B1	B2	C	D	D2	D3	S	no. of holes	H						PACKING DIMENSIONS			VOLUME (m ³)	WEIGHT kg			
										IE2	IE3	H1	H2	L	L1	L2	M	L/A		L/B	H	IE2	IE3
CP-G 125-4750/A/BAQE/37	292	252	210	230	125	210	250	18	8	1188	1198	215	528	620	310	310	M16	1125	680	1300	0,995	430	444
CP-G 125-5300/A/BAQE/45	315	252	235	230	125	210	250	18		1238	1243	215	528	620	310	310	M16	760	725	1500	0,827	478	507
CP-G 125-5800/A/BAQE/55	372	275	275	230	125	210	250	18		1333	1333	215	558	620	310	310	M16	760	725	1500	0,827	502	539