

CME /CM-GE / DCME / DCM-GE

ELECTRONIC IN-LINE PUMPS FOR CIRCULATION SYSTEMS



TECHNICAL DATA

Operating range:

from 1,2 to 360 m³/h with head up to 34 metres

Pumped liquid: clean, free of solids and abrasives, non-viscous, non-aggressive, non-crystallised and chemically neutral, with properties similar to water.

Maximum operating pressure:

PN10 : DN 40 - DN 50

PN16 : Remainder of the range

Flanging: PN 16.

Counter flanges on request:

DN 40 - DN 50 - DN 65 - DN 80 - DN 100 - DN 125 - DN 150; PN 16.

Protection: IP 55

Insulation: class F

Liquid temperature range:

-10 °C to +130 °C for DN 40 - 50

-10 °C to +140 °C for the remainder of the range

Maximum ambient temperature: +40°C

Maximum working pressure: 16 bar

Standard single-phase voltage: 1x220-240 V / 50-60 Hz

Special version on request:

three-phase 3x400 V / 50 Hz or three-phase 3x460 V / 60 Hz

Standard three-phase voltage: 3x400 V / 50 Hz

Special version on request: 3x460 V / 60 Hz

Pumped liquid: clean, free of solids and abrasives, non-viscous, non-aggressive, non-crystallised and chemically neutral.

APPLICATIONS

In-line port circulation pumps, suitable for heating, air conditioning, refrigeration and sanitary water systems. Particularly versatile thanks to the use of the MCE/C inverter, offering performance features capable of automatically adapting to the different needs of the system, keeping a consistent differential pressure. Available in the single and twin versions.

CONSTRUCTION FEATURES OF THE PUMP

PN 16 flanged suction and delivery ports with threaded holes for control manometers. Cast iron pump body and motor support, cast iron or technopolymer impeller depending on mode (bronze impeller available on request for DN 65 to DN 150 models only). Stainless steel motor shaft. Seal device: standardised mechanical seal according to DIN 24960 in carbon/silicon carbide with EPDM OR rings.

CONSTRUCTION FEATURES OF THE MOTOR

External ventilation asynchronous type motor. Rotor running on ball bearings, oversized to ensure low noise and durability. Construction according to CEI 2-3.

CONSTRUCTION FEATURES OF THE ELECTRONICS: MCE/C INVERTER

MCE/C inverters are the latest technological achievement of the DAB inverter range. They represent a new generation of inverters for use with circulation pumps, and set themselves apart due to ease of use, power, simplicity of installation and management. MCE/C inverters have been designed for managing circulation pumps. By allowing a simple adjustment of the differential pressure, they give the possibility of adjusting the performance of the circulation pump to the actual system requirements. They are fitted on the fan cover of the motor. This makes the installation of the pump with MCE/C particularly easy and quick. The protection class of the MCE/C is IP55. The ease of programming is guaranteed by the use of a simple and intuitive interface, similar to Dialogue electronic circulators, and a graphic display. MCE/C inverters have a double micro-processor construction that guarantees maximum efficiency and reliability.

A reliable and sturdy construction, together with a modern and innovative design, complete the product, also in terms of aesthetic value. MCE/C inverters protect the motor and the pump, and increase their life, by eliminating hammering effects and making the pump rotate at the minimum number of rotations capable of meeting the requirements of the user. In addition, electric pumps controlled by the MCE/C inverter are environmentally friendly. In fact, by ensuring that the pump only uses the power that is strictly necessary for meeting the needs of the users, electricity consumption is strongly reduced when compared with fixed speed pumps. It is possible to create twin units by using the appropriate cable for the connection of MCE/C inverters.

CME /CM-GE / DCME / DCM-GE

ELECTRONIC IN-LINE PUMPS FOR CIRCULATION SYSTEMS

MATERIALS

N.	PARTS	MATERIALS
1	PUMP BODY	CAST IRON 250 UNI ISO 185
3	SUPPORT	CAST IRON 250 UNI ISO 185
4	IMPELLER	CAST IRON DN 65-80-100-125-150 / DCME Dn 40 - 50 / CME 40-1450T, CME 50-1420T
		TECHNOPOLYMER B CME 40-870T, CME 50-1000T
7	SHAFT WITH ROTOR	AISI 303 STAINLESS STEEL X10 CrNiS 1809 UNI 6900/71
16	MECHANICAL SEAL	CARBON/GRAPHITE
28	OR RING	EPDM RUBBER

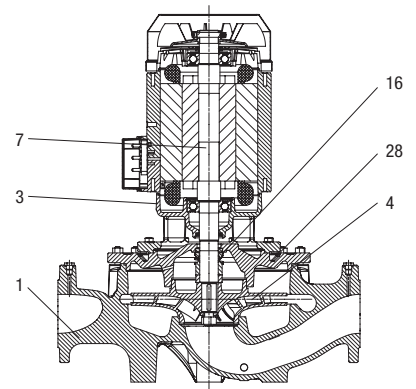

* In contact with the liquid

- Legend: (example)

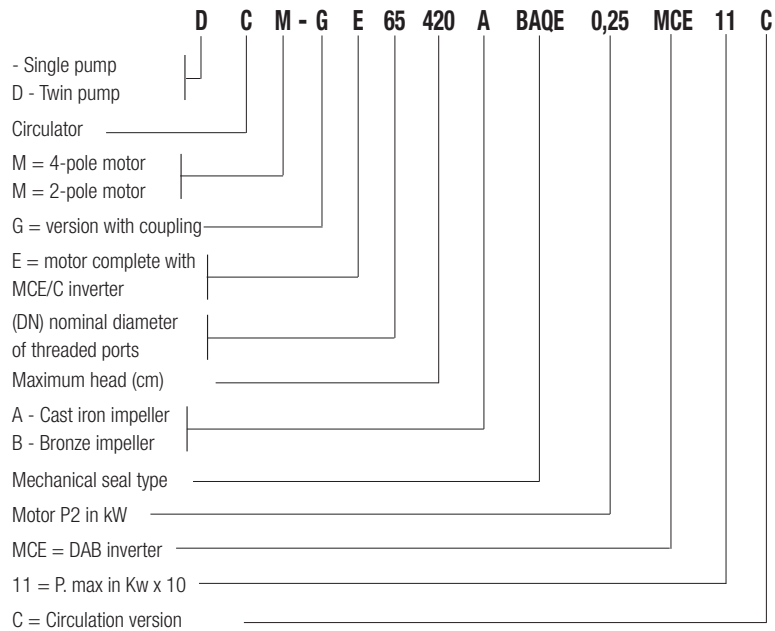

Installation: horizontal or vertical position, provided that the motor is always above the pump.

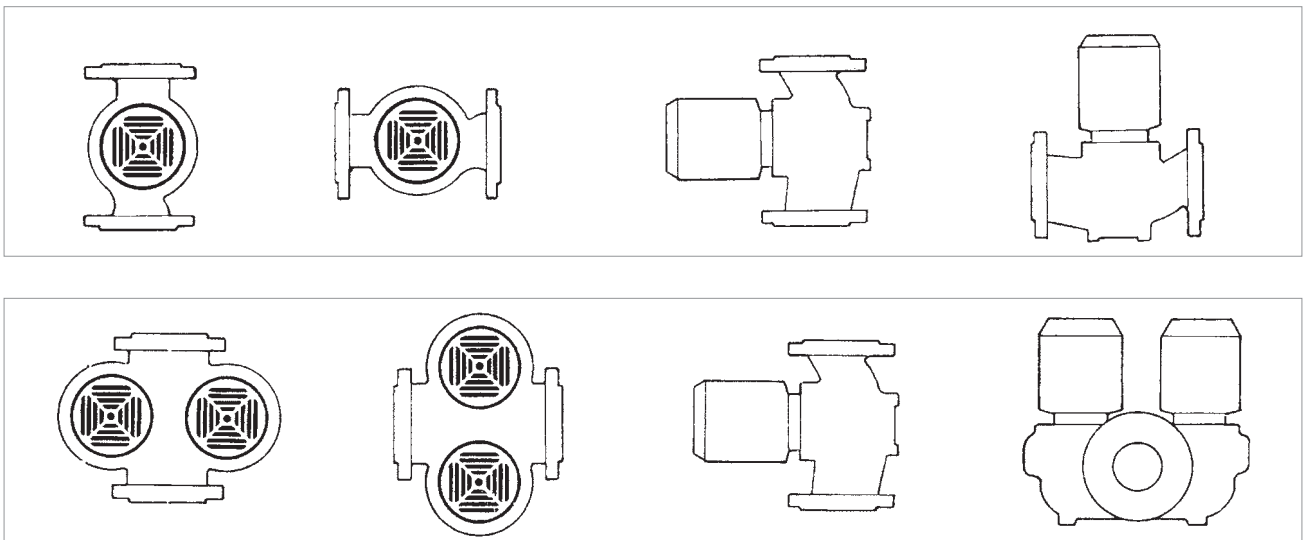

MCE/C INVERTER

MODES OF OPERATION

All the functions listed below can be consulted by the users (including less experienced ones) by simply scrolling through the MCE/C menu. The calibration and the modification of the parameters are protected, and can only be completed by expert users.

1 - ΔP -c constant differential pressure adjustment mode

The ΔP -c adjustment mode keeps the differential pressure of the system constantly at the H (setp) value set, even in case of variation of the flow rate. This is the standard adjustment used. It can be set directly from the MCE/C control panel. The inverter keeps the differential pressure (H setp) constant even in case of flow variation.

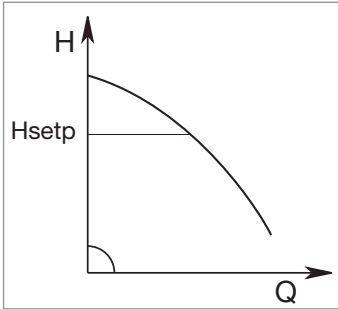

This adjustment is particularly indicated for the following systems:

- a. two-pipe heating systems with thermostat valves**
- b. underfloor heating systems with thermostat valves**
- c. single-pipe heating systems with thermostat valves and calibration valves**
- d. systems with primary circuit pumps**

2 - Constant curve adjustment modes

2.1 - Constant curve adjustment

The rotation speed is kept at a constant number of revolutions. This rotation speed can be set between a minimum value and the nominal frequency of the circulation pump (e.g. between 15 Hz and 50 Hz). This mode can be set using the control panel on the MCE cover.

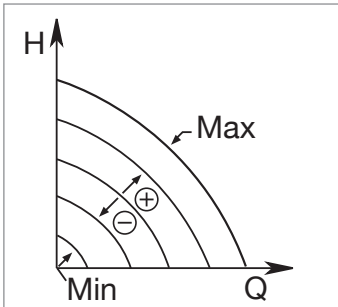

2.2 - Adjustment of the constant curve with external analogue signal

The rotation speed is kept at a constant number of revolution in proportion with the voltage of the external analogue signal.

The rotation speed changes in a linear way, between the nominal frequency of the pump when $V_{in} = 10$ V, and the minimum frequency when $V_{in} = 0$ V.

This mode can be set using the control panel on the MCE cover.

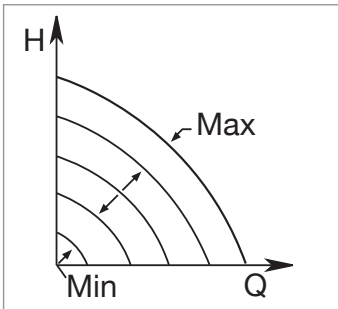

3 - ΔP -v * proportional differential pressure adjustment mode

With ΔP -v adjustment mode, with the variation of the flow rate, the value of the delivery of the head also varies in a linear manner, from Hsetp to Hsetp/2.

* in order to know the availability of the function on specific models contact our customer service.

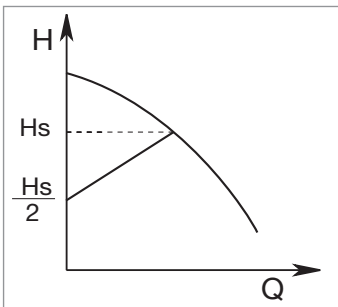

For more information refer to the technical appendix.

ELECTRIC IN-LINE PUMPS

ELECTRONIC IN-LINE PUMPS FOR CIRCULATION SYSTEMS

PERFORMANCE RANGE

The performance curves are based on kinematic viscosity values = 1 mm²/s and density equal to 1000 kg/m³. Curve tolerance according to ISO 9906.

GRAPHIC SELECTION TABLE

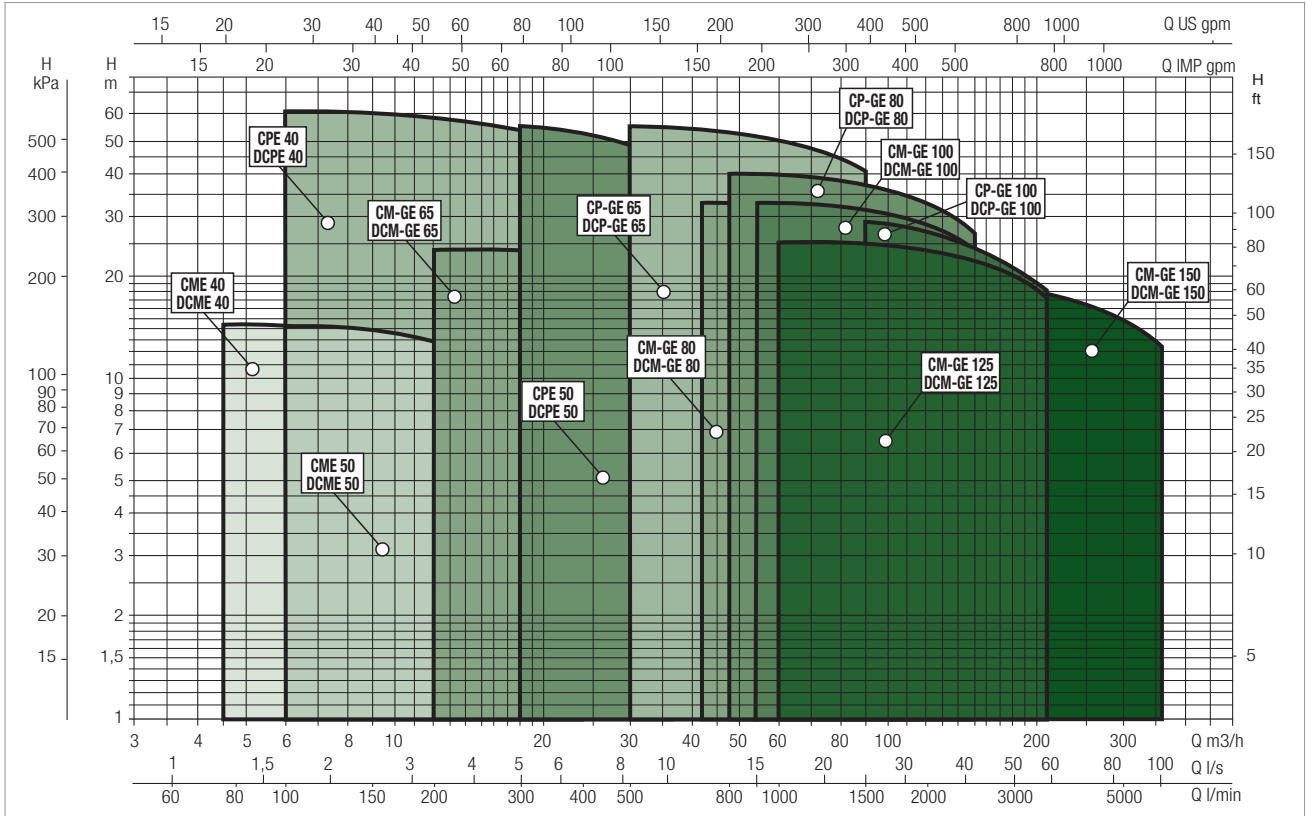

SELECTION TABLE - CME / CM-GE - 4 POLES

MODEL	Q= m ³ /h														Q= l/min													
	0	1,2	2,4	3	3,6	4,5	4,8	6	12	18	24	30	36	42	48	54	60	66	72	78	84	90	102	114				
CME 40- 870 M MCE11/C IE2	8,7	8,7	8,6	8,6	8,5	8,3	8,3	8,2	5																			
CME 40-1450 M MCE11/C IE2						14,5	14,4	14,3	11,8	8																		
CME 40-1450 T MCE30/C IE2						14,5	14,4	14,3	11,8	8																		
CME 50-1000 M MCE11/C IE2					10,1	10	9,8	9,6	6,8																			
CME 50-1420 M MCE11/C IE2							14,2	13	10	6																		
CME 50-1420 T MCE30/C IE2							14,2	13	10	6																		
CM-GE 65- 660/A/BAQE/0.55 M MCE11/C IE2	6,6						6,5	6,2	5,7	4,8																		
CM-GE 65- 920/A/BAQE/0.75 M MCE11/C IE2	9,2						9,2	9	8,4	7,4	5,7																	
CM-GE 65- 920/A/BAQE/0.75 T MCE30/C IE2	9,2						9,2	9	8,4	7,4	5,7																	
CM-GE 65-1200/A/BAQE/1.5 M MCE15/C IE2	12							12	11,9	11,5	10,8	10,1	8,9															
CM-GE 65-1200/A/BAQE/1.5 T MCE30/C IE2	12							12	11,9	11,5	10,8	10,1	8,9															
CM-GE 65-1680/A/BAQE/3 T MCE30/C IE2	16,8							16,8	16,5	16,1	15,5	14,6	13,6	12,4	10,9													
CM-GE 65-2380/A/BAQE/4 T MCE30/C IE2	23,8							24	23,8	23,4	22,7	21,6	20,4	19	17,1													

CME /CM-GE / DCME / DCM-GE

ELECTRONIC IN-LINE PUMPS FOR CIRCULATION SYSTEMS

SELECTION TABLE - CME / CM-GE - 4 POLES

MODEL	Q=	0	1,2	2,4	3	3,6	4,5	4,8	6	12	18	24	30	36	42	48	54	60	66	72	78	84	90	102	114		
	m ³ /h	0	20	40	50	60	75	80	100	200	300	400	500	600	700	800	900	1000	1100	1200	1300	1400	1500	1700	1900		
	Q=																										
	l/min																										
CM-GE 80- 650/A/BAQE/0.75 M MCE11/C IE2		6,5								6,3	6,1	5,8	5,5	5	4,5	3,9											
CM-GE 80- 650/A/BAQE/0.75 T MCE30/C IE2		6,5								6,3	6,1	5,8	5,5	5	4,5	3,9											
CM-GE 80- 890/A/BAQE/1.5 M MCE15/C IE2		8,9									8,8	8,7	8,6	8,3	8	7,6	7,2	6,6	6								
CM-GE 80- 890/A/BAQE/1.5 T MCE30/C IE2		8,9									8,8	8,7	8,6	8,3	8	7,6	7,2	6,6	6								
CM-GE 80-1530/A/BAQE/3 T MCE30/C IE2		15,3										15,4	15,3	15	14,6	14,1	13,5	12,9	12,2	11,3							
CM-GE 80-1700/A/BAQE/4 T MCE30/C IE2		17											17,2	17,2	17,1	16,8	16,5	16,2	15,7	15,1	14,3	13,6	12,6				
CM-GE 80-2410/A/BAQE/5.5 T MCE55/C IE2		24,1												23,8	23,6	23,3	22,8	22,3	21,5	20,8	19,7	18,6	17,3				
CM-GE 80-2700/A/BAQE/7.5 T MCE110/C IE2		27														26	25,5	25	24,5	23,6	22,7	21,5	20,2	19			
CM-GE 80-3420/A/BAQE/11 T MCE110/C IE2		34,2															33,2	33	32,5	32	31,5	30,7	29,8	29	28	25	21,7

MODEL	Q=	0	12	18	24	30	36	42	48	54	60	66	72	78	84	90	102	114	120	150	180	210	240	250	270	330	360		
	m ³ /h	0	200	300	400	500	600	700	800	900	1000	1100	1200	1300	1400	1500	1700	1900	2000	2500	3000	3500	4000	4167	4500	5500	6000		
	Q=																												
	l/min																												
CM-GE 100- 510/A/BAQE/0.75 M MCE11/C IE2		5,1	4,9	4,8	4,7	4,7	4,4	4,2	3,8	3,4	3																		
CM-GE 100- 510/A/BAQE/0.75 T MCE30/C IE2		5,1	4,9	4,8	4,7	4,7	4,4	4,2	3,8	3,4	3																		
CM-GE 100- 865/A/BAQE/1.5 M MCE15/C IE2		8,6				8,3	8,2	8,1	7,9	7,7	7,5	7,3	7,1	6,8	6,5	6,2	5,6	4,8											
CM-GE 100- 865/A/BAQE/1.5 T MCE30/C IE2		8,6				8,3	8,2	8,1	7,9	7,7	7,5	7,3	7,1	6,8	6,5	6,2	5,6	4,8											
CM-GE 100-1020/A/BAQE/3 T MCE30/C IE2		10,2				10,2	10,1	10	9,9	9,8	9,7	9,5	9,3	9	8,8	8,6	7,9	7,2	6,7										
CM-GE 100-1320/A/BAQE/4 T MCE55/C IE2		13,2						13,2	13,2	13,1	12,9	12,7	12,4	12	11,7	11,3	10,4	9,3	8,7										
CM-GE 100-1650/A/BAQE/5.5 T MCE55/C IE2		16,5						16,6	16,5	16,4	16,2	16,1	16	15,7	15,4	15	14,3	13,3	12,7										
CM-GE 100-2050/A/BAQE/7.5 T MCE110/C IE2		20,5						21	21	21	20,7	20,5	20	19,8	19,5	19	18	16,7	16										
CM-GE 100-2550/A/BAQE/11 T MCE110/C IE2		25,5						25,5	25,5	25,5	25,1	25	25	24,6	24,2	24	23	21,5	21										
CM-GE 100-3290/A/BAQE/15 T MCE150/C IE2	H (m)	32,9								33,1	33	32,9	32,8	32,4	32	31,6	30,5	29,5	28,9	24									
CM-GE 125-1075/A/BAQE/4 T MCE55/C IE2		10,8								10,1	10,1	10	9,9	9,7	9,5	9,1	8,5	8,3	7	5,4									
CM-GE 125-1270/A/BAQE/5.5 T MCE55/C IE2		12,7								12,6	12,6	12,5	12,5	12,4	12,3	12	11,5	11,4	10,1	8,5									
CM-GE 125-1560/A/BAQE/7.5 T MCE110/C IE2		15,6								15,4	15,4	15,3	15,2	15,1	15	14,7	14,5	14,3	13,3	11,6	9,8								
CM-GE 125-2100/A/BAQE/11 T MCE110/C IE2		21								21,5	21,5	21,5	21,4	21,2	21	20,9	20	19,8	18	16									
CM-GE 125-2550/A/BAQE/15 T MCE150/C IE2		25,5								25,5	25,5	25,5	25,3	25,1	25,1	25	24,5	24	22,5	20,5	17,5								
CM-GE 150- 955/A/BAQE/5.5 T MCE55/C IE2		9,6													9,6	9,5	9,4	9,3	8,7	7,8	6,7	5,9	5,5						
CM-GE 150-1322/A/BAQE/7.5 T MCE110/C IE2		13,2													13	12,8	12,6	12,5	11,9	11,1	10,1	8,9	8,5						
CM-GE 150-1600/A/BAQE/11 T MCE110/C IE2		16															15,5	15,5	15,4	14,8	14	13	11,8	11	10,5	9,2			
CM-GE 150-1950/A/BAQE/15 T MCE150/C IE2		19,5																19,5	19,4	19,3	19,2	18,7	17,8	16,8	16	15,5	14,1	12,5	

CME /CM-GE / DCME / DCM-GE

ELECTRONIC IN-LINE PUMPS FOR CIRCULATION SYSTEMS

SELECTION TABLE - DCME / DCM-GE - 4 POLES

MODEL	Q=	0	3	4,5	6	12	18	24	30	36	42	48	54	60	66	72	78	84	90	102	114	120	150		
	m ³ /h	0	50	75	100	200	300	400	500	600	700	800	900	1000	1100	1200	1300	1400	1500	1700	1900	2000	2500		
	Q=																								
	l/min																								
DCME 40-620 M MCE11/C	H (m)	6,3	6,2	6,0	5,8	3,0																			
DCME 50-460 M MCE11/C	H (m)	4,8			4,6	3,9	2,4																		
DCME 50-880 M MCE11/C	H (m)	9,1			8,8	7,7	5,9																		
DCM-GE 65- 660/A/BAQE/0.55 M MCE11/C	H (m)	6,5			6,4	5,9	4,4	3,1																	
DCM-GE 65- 920/A/BAQE/0.75 M MCE11/C	H (m)	9,1			9,1	8,8	7,4	5,8	3,5																
DCM-GE 65- 920/A/BAQE/0.75 T MCE30/C	H (m)	9,1			9,1	8,8	7,8	6,4	4,5																
DCM-GE 65-1200/A/BAQE/1.5M MCE15/C	H (m)	12,0				11,9	11,6	11,0	10,0	9,0	7,6														
DCM-GE 65-1200/A/BAQE/1.5 T MCE30/C	H (m)	12,0				11,9	11,6	11,0	10,0	9,0	7,6														
DCM-GE 65-1680/A/BAQE/3 T MCE30/C	H (m)	16,8				16,7	16,3	15,7	14,9	13,7	12,4	11,0	9,3												
DCM-GE 65-2380/A/BAQE/4 T MCE30/C	H (m)	23,8				23,9	23,5	22,8	21,8	20,3	18,6	16,8	14,5												
DCM-GE 80- 650/A/BAQE/0.75 M IE2 MCE11/C	H (m)	6,5				6,2	5,8	5,2	4,5	3,7	2,9	2,1													
DCM-GE 80- 650/A/BAQE/0.75 T MCE30/C	H (m)	6,5				6,2	5,8	5,2	4,5	3,7	2,9	2,1													
DCM-GE 80- 890/A/BAQE/1.5 M MCE15/C	H (m)	8,5						8,3	8,0	7,5	6,8	6,1	5,3	4,4	3,5										
DCM-GE 80- 890/A/BAQE/1.5 T MCE30/C	H (m)	8,5						6,7	6,2	5,5	4,8	4,2	3,5	2,9	2,3										
DCM-GE 80-1530/A/BAQE/3T MCE30/C	H (m)	14,4						14,1	13,7	13,0	12,2	11,3	10,2	9,2	8,0	6,8									
DCM-GE 80-1700/A/BAQE/4 T MCE30/C	H (m)	16,0						15,7	15,5	15,3	14,6	14,0	13,2	12,3	11,2	10,0	8,9	7,7							
DCM-GE 80-2410/A/BAQE/5.5T MCE55/C	H (m)	24,1								23,3	22,7	22,0	21,1	20,2	18,9	17,6	16,2								
DCM-GE 80-2700/A/BAQE/7.5 T MCE110/C	H (m)	27,0								26,1	26,1	25,5	24,9	24,2	23,2	22,1	20,7	19,3	17,9						
DCM-GE 80-3420/A/BAQE/11 T MCE110/C	H (m)	34,2								33,3	33,3	32,9	32,3	31,8	30,9	29,9	29,0	27,8	24,4	22,0	20,8				
DCM-GE 100- 510/A/BAQE/0.75 M MCE11/C	H (m)	4,9				4,8	4,7	4,6	4,5	4,0	3,7	3,2	2,6	2,1											
DCM-GE 100- 510/A/BAQE/0.75 T MCE30/C	H (m)	4,9				4,8	4,7	4,6	4,5	4,0	3,7	3,2	2,6	2,1											
DCM-GE 100- 865/A/BAQE/1.5 M MCE15/C	H (m)	8,6							8,4	8,3	8,1	7,9	7,6	7,4	7,1	6,8	6,4	6	5,6	4,7	3,5				
DCM-GE 100- 865/A/BAQE/1.5 T MCE30/C	H (m)	8,6							8,4	8,3	8,1	7,9	7,6	7,4	7,1	6,8	6,4	6	5,6	4,7	3,5				
DCM-GE 100-1020/A/BAQE/3 T MCE30/C	H (m)	10,2							10,2	10,0	9,8	9,6	9,5	9,3	8,9	8,5	8,0	7,5	7,1	5,9	4,7	4,0			
DCM-GE 100-1320/A/BAQE/4 T MCE55/C	H (m)	13,2									13,2	13,1	13,0	12,8	12,4	11,9	11,3	10,8	10,2	8,8	7,4	6,6			
DCM-GE 100-1650/A/BAQE/5,5T MCE55/C	H (m)	16,5									16,5	16,4	16,3	16,0	15,8	15,5	14,9	14,4	13,7	12,4	10,8	10,0			
DCM-GE 100-2050/A/BAQE/7.5 T MCE110/C	H (m)	19,3											19,2	18,8	18,5	17,9	17,6	17,2	16,6	15,5	14,1	13,3			
DCM-GE 100-2550/A/BAQE/11 T MCE110/C	H (m)	24,0												23,3	22,8	22,6	22,4	21,9	21,4	21,0	19,8	18,1	17,5		
DCM-GE 100-3290/A/BAQE/15 T MCE150/C	H (m)	30,9													30,5	30,3	30,1	29,9	29,4	28,8	28,3	27,0	25,8	25,1	20,0

SELECTION TABLE - DCM-GE - 4 POLES

MODEL	Q=	0	30	36	42	48	54	60	66	72	78	84	90	102	114	120	150	180	210	240	250	270	330	360	
	m ³ /h	0	500	600	700	800	900	1000	1100	1200	1300	1400	1500	1700	1900	2000	2500	3000	3500	4000	4167	4500	5500	6000	
	Q=																								
	l/min																								
DCM-GE 125-1075/A/BAQE/4 T MCE55/C	H (m)	10,0						9,5	9,4	9,2	9,0	8,7	8,4	7,7	6,8	6,5	4,4	2,4							
DCM-GE 125-1270/A/BAQE/5.5 T MCE55/C	H (m)	11,7						11,8	11,7	11,5	11,4	11,1	10,8	10,2	9,2	8,9	6,4	3,8							
DCM-GE 125-1560/A/BAQE/7.5 T MCE110/C	H (m)	14,4						14,6	14,6	14,4	14,2	14,0	13,8	13,2	12,7	12,3	10,2	7,5	4,9						
DCM-GE 125-2100/A/BAQE/11 T MCE110/C	H (m)	20,1										19,9	19,6	19,3	18,2	17,8	15,4	12,7							
DCM-GE 125-2550/A/BAQE/15 T MCE150/C	H (m)	24,5										23,8	23,7	23,4	22,7	22,1	20,0	17,4	13,9						
DCM-GE 150- 955/A/BAQE/5.5 T IE2 MCE55/C	H (m)	9,6														8,1	7,0	6,2	4,9	3,5	2,8				
DCM-GE 150-1322/A/BAQE/7.5T MCE110/C	H (m)	11,8											11,5	11,5	11,4	11,0	10,0	8,5	7,2	6,0	5,5				
DCM-GE 150-1600/A/BAQE/11 T IE2 MCE110/C	H (m)	14,8												14,2	14,2	14,0	13,4	12,5	11,4	10,1	9,4	8,8			
DCM-GE 150-1950/A/BAQE/15 T MCE150/C	H (m)	18,1													17,9	17,8	17,7	17,5	16,9	15,9	14,8	14,0	13,5	10,5	8,9

DCME 40 4 POLES - ELECTRONIC IN-LINE PUMPS FOR HEATING, AIR CONDITIONING, REFRIGERATION, SOLAR, AND SANITARY SYSTEMS - SINGLE, FLANGED, WITH MCE/C INVERTER

Pumped liquid temperature range: from -10 °C to +130°C - Maximum ambient temperature: +40°C

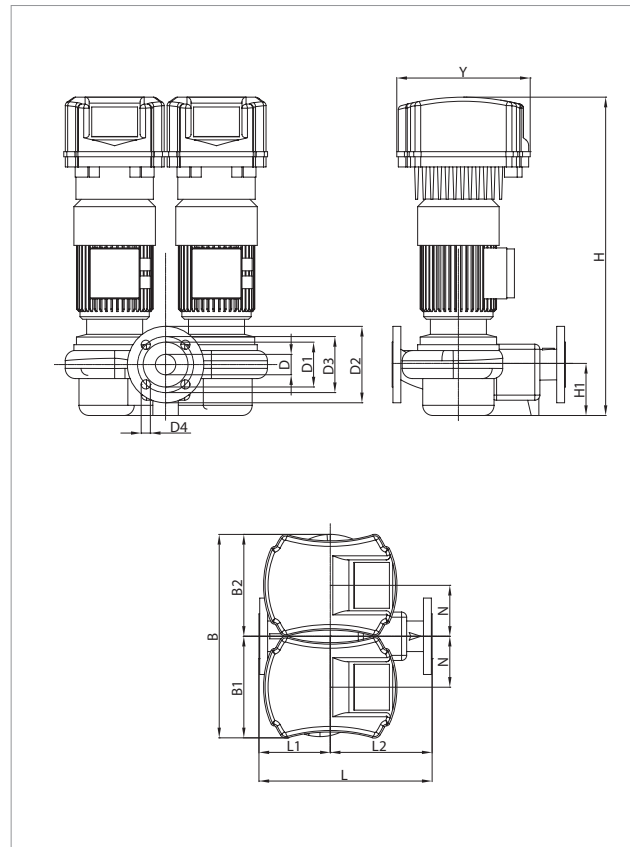
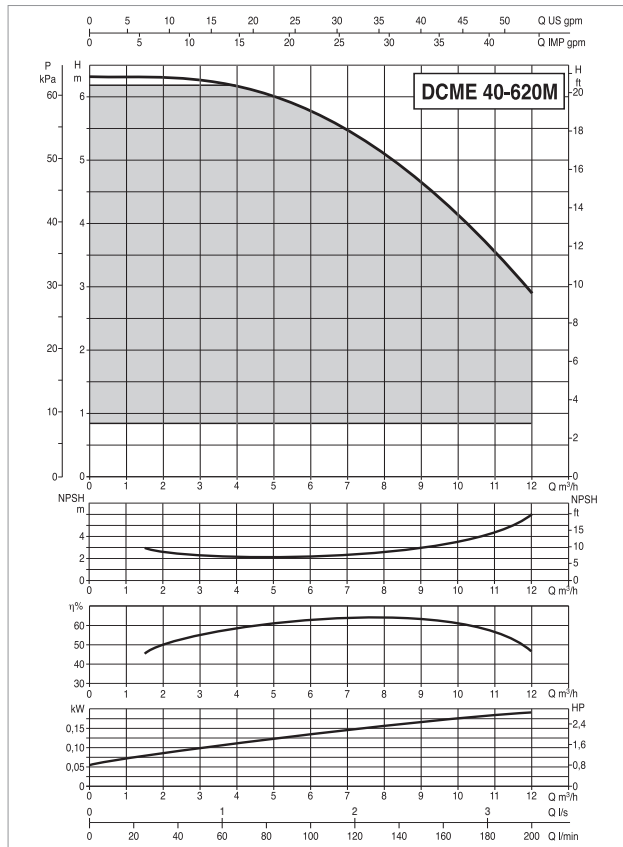

For the MEI index refer to the hydraulic data of the individual pump.

The performance curves are based on kinematic viscosity values = 1 mm²/s and density equal to 1000 kg/m³. Curve tolerance according to ISO 9906.

MODEL	ELECTRICAL DATA						
	POWER INPUT 50-60 Hz	MOTOR TYPE	n r.p.m.	P1 MAX W	P2 NOMINAL		In A
					kW	HP	
DCME 40-620 M MCE11/C	1x220 - 240 V ~	4 poles	1450	0,43	0,25	0,33	4,7

MODEL	L	L1	L2	B	B1	B2	H	H1	N	D	D1	D2	D3	D4	Y	PACKING DIMENSIONS			VOLUME (m ³)	WEIGHT kg
	L/A	L/B	H																	
DCME 40-620 M MCE11/C	340	130	210	400	200	200	625	100	100	40 PN16	88	150	110	4 HOLES Ø18	262	520	400	710	0,15	45

DCME 50 4 POLES - ELECTRONIC IN-LINE PUMPS FOR HEATING, AIR CONDITIONING, REFRIGERATION, SOLAR, AND SANITARY SYSTEMS - TWIN, FLANGED, WITH MCE/C INVERTER

Pumped liquid temperature range: from -10 °C to +130°C - Maximum ambient temperature: +40°C

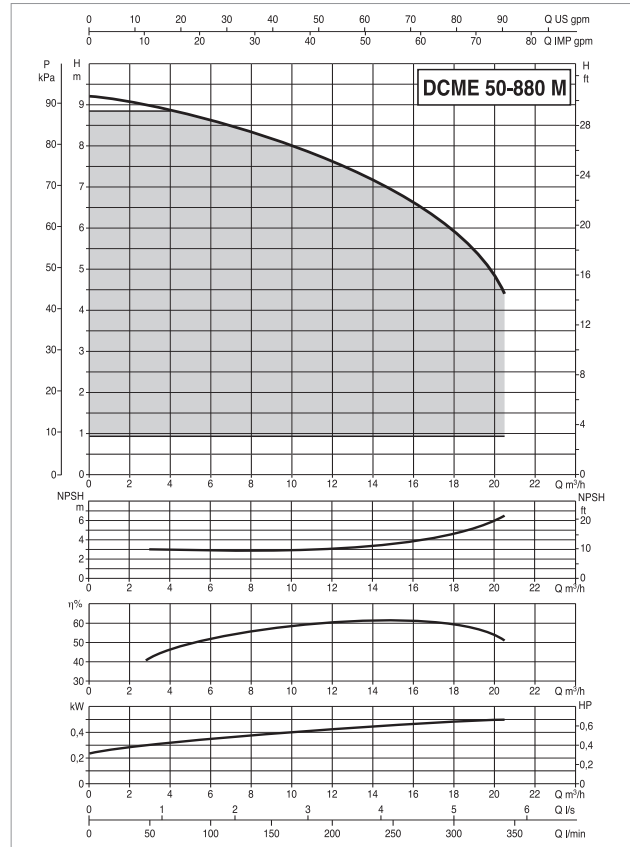
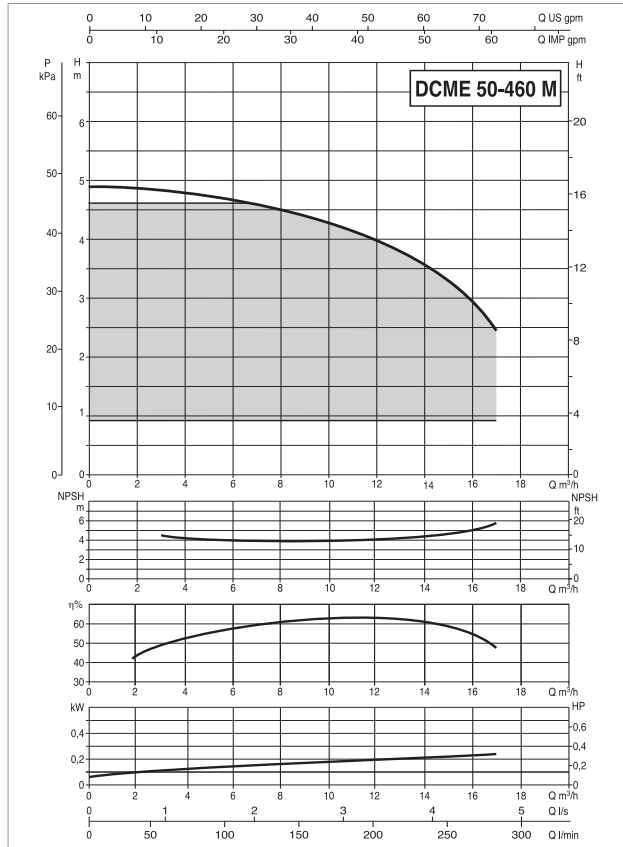

For the MEI index refer to the hydraulic data of the individual pump.

The performance curves are based on kinematic viscosity values = 1 mm²/s and density equal to 1000 kg/m³. Curve tolerance according to ISO 9906.

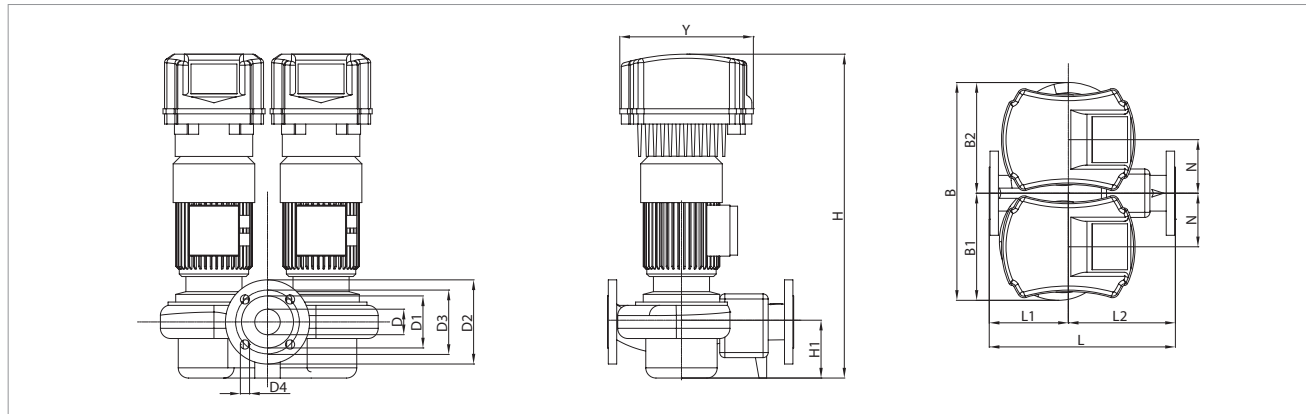

MODEL	ELECTRICAL DATA						
	POWER INPUT 50-60 Hz	MOTOR TYPE	n r.p.m.	P1 MAX W	P2 NOMINAL		In A
					kW	HP	
DCME 50-460 M MCE11/C IE2	1x220 - 240 V ~	4 poles	1450	0,43	0,25	0,33	4,7
DCME 50-880 M MCE11/C IE2		4 poles	1450	0,83	0,5	0,67	7,2

MODEL	L	L1	L2	B	B1	B2	H	H1	N	D	D1	D2	D3	D4	Y	PACKING DIMENSIONS			VOLUME (m ³)	WEIGHT kg
																L/A	L/B	H		
																4 HOLES Ø18				
DCME 50-460 M MCE11/C IE2	365	145	220	427	217	210	635	110	105	50 PN16	102	165	125	262	262	520	400	710	0,15	50
DCME 50-880 M MCE11/C IE2	410	170	240	480	235	245	635	110	105	50 PN16	102	165	125	262	262	520	400	710	0,15	56

DCM-GE 65 4 POLES - ELECTRONIC IN-LINE PUMPS FOR HEATING, AIR CONDITIONING, REFRIGERATION, SOLAR, AND SANITARY SYSTEMS - TWIN, FLANGED, WITH MCE/C INVERTER

Pumped liquid temperature range: from -10 °C to +140°C - Maximum ambient temperature: +40°C

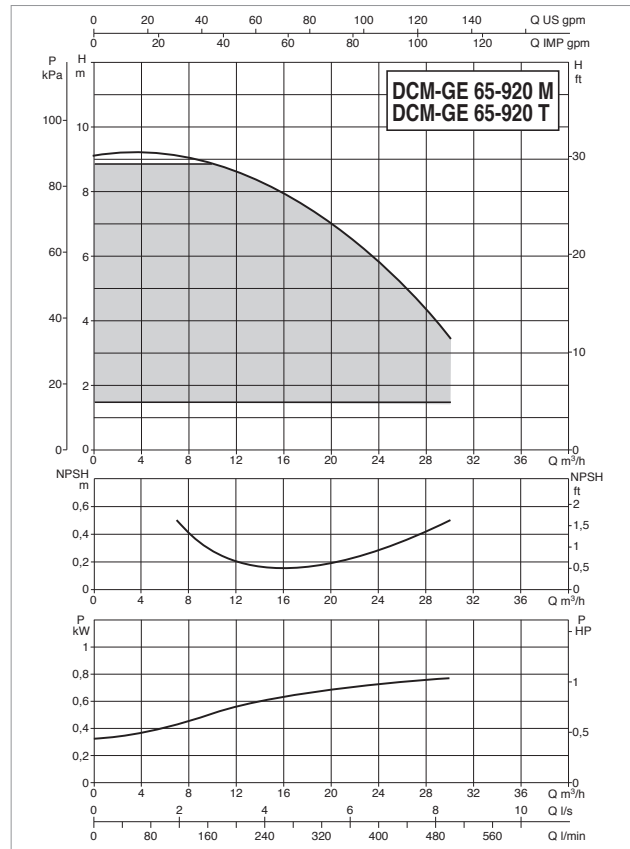
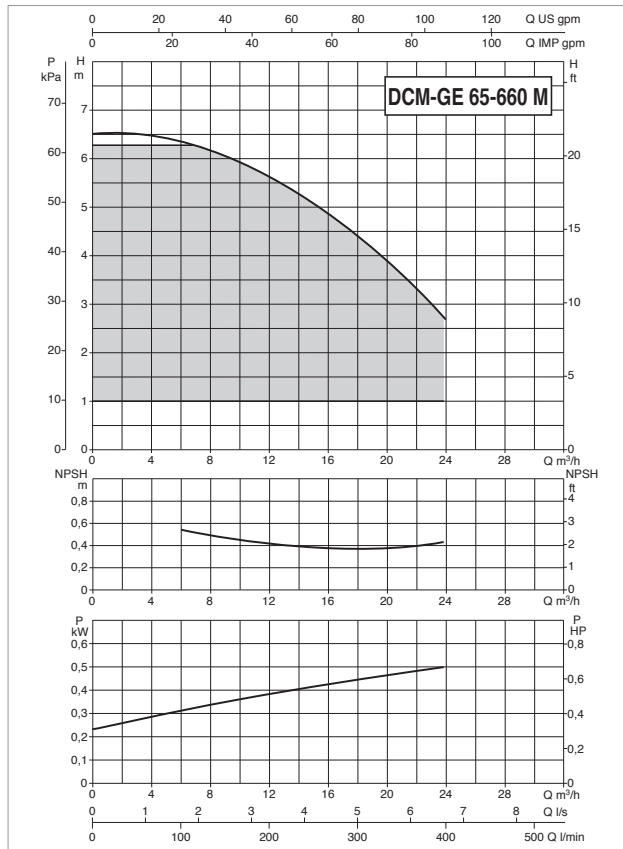

For the MEI index refer to the hydraulic data of the individual pump.

The performance curves are based on kinematic viscosity values = 1 mm²/s and density equal to 1000 kg/m³. Curve tolerance according to ISO 9906.

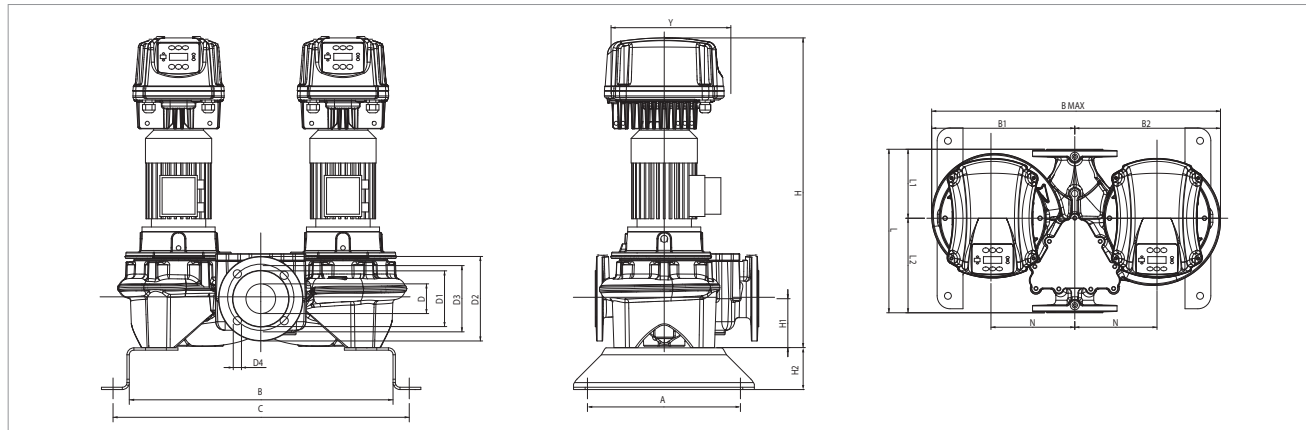

MODEL	ELECTRICAL DATA						
	POWER INPUT 50-60 Hz	MOTOR TYPE	n r.p.m.	P1 MAX W	P2 NOMINAL		In A
					kW	HP	
DCME-GE 65- 660/A/BAQE/ 0.55 M MCE11/C IE2 *	1x220-240 V ~	4 poles	1400	0,84	0,55	0,8	7,3
DCM-GE 65- 920/A/BAQE/ 0.75 M MCE11/C IE2 *					0,75	1	9,8
DCM-GE 65- 920/A/BAQE/ 0.75 T MCE30/C IE2 *	3x400 V ~	4 poles	1430	1,23	0,75	1	t.b.d.

* ΔP-v proportional differential pressure adjustment mode also available.

MODEL	A	B	C	B1	B2	B max	D1	D2	D3	D4	no. of holes	Y	H	H1	H2	L	L1	L2	M	N	PACKING DIMENSIONS			VOL. (m³)	WEIGHT kg
																					L/A	L/B	H		
DCM-GE 65- 660/A/BAQE/ 0.55 M MCE11/C IE2	330	569	639	315	320	635	122	185	145	18	4	262	733	107	100	358	151	207	M16	180	358	635	733	0,17	141
DCM-GE 65- 920/A/BAQE/ 0.75 M MCE11/C IE2	330	569	639	315	320	635	122	185	145	18		262	733	107	100	358	151	207	M16	180	358	635	733	0,17	144
DCM-GE 65- 920/A/BAQE/ 0.75 T MCE30/C IE2	330	569	639	315	320	635	122	185	145	18		262	730	107	100	358	151	207	M16	180	358	635	730	0,17	146

DCM-GE 65 4 POLES - ELECTRONIC IN-LINE PUMPS FOR HEATING, AIR CONDITIONING, REFRIGERATION, SOLAR, AND SANITARY SYSTEMS - TWIN, FLANGED, WITH MCE/C INVERTER

Pumped liquid temperature range: from -10 °C to +140°C - Maximum ambient temperature: +40°C

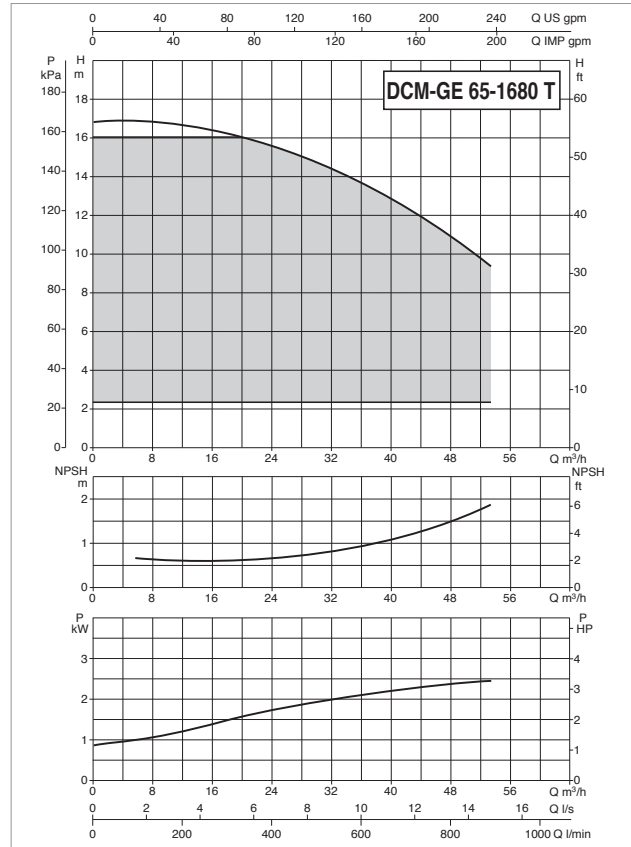
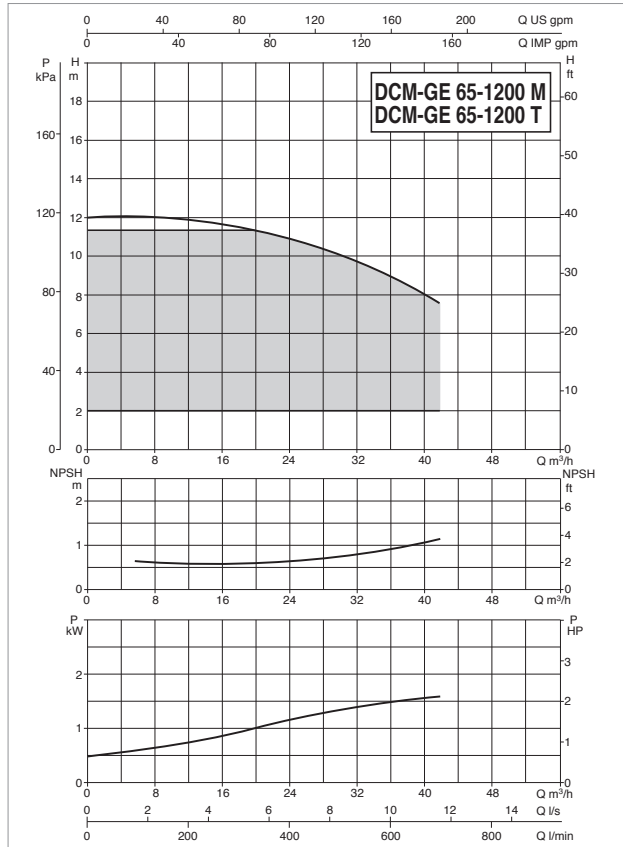

For the MEI index refer to the hydraulic data of the individual pump.

The performance curves are based on kinematic viscosity values = 1 mm²/s and density equal to 1000 kg/m³. Curve tolerance according to ISO 9906.

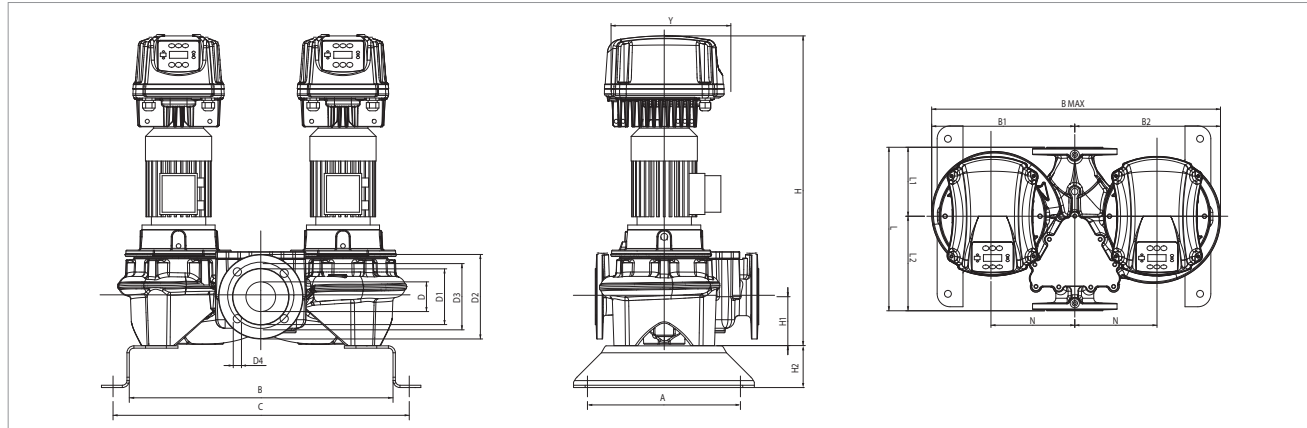

MODEL	ELECTRICAL DATA						
	POWER INPUT 50-60 Hz	MOTOR TYPE	n r.p.m.	P1 MAX W	P2 NOMINAL		In A
					kW	HP	
DCM-GE 65-1200/A/BAQE/ 1.5 M MCE15/C IE2 *	1x220-240 V ~	4 poles	1430	2,10	1,5	2	15,4
DCM-GE 65-1200/A/BAQE/ 1.5 T MCE30/C IE2 *	3x400 V ~	4 poles	1430	2,10	1,5	2	t.b.d.
DCM-GE 65-1680/A/BAQE/ 3 T MCE30/C IE2 *		4 poles	1448	2,83	3	4	6,6

* ΔP-v proportional differential pressure adjustment mode also available.

MODEL	A	B	C	B1	B2	B max	D1	D2	D3	D4	no. of holes	Y	H	H1	H2	L	L1	L2	M	N	PACKING DIMENSIONS			VOL. (m ³)	WEIGHT kg
																					L/A	L/B	H		
DCM-GE 65-1200/A/BAQE/ 1.5 M MCE15/C IE2	330	649	719	387	395	782	122	185	145	18	4	262	821	125	100	475	177	298	M16	220	475	782	821	0,30	195
DCM-GE 65-1200/A/BAQE/ 1.5 T MCE30/C IE2	330	649	719	387	395	782	122	185	145	18		262	824	125	100	475	177	298	M16	220	475	782	824	0,31	193
DCM-GE 65-1680/A/BAQE/ 3 T MCE30/C IE2	330	649	719	387	395	782	122	185	145	18		352	840	125	100	475	177	298	M16	220	475	782	840	0,31	206

DCM-GE 65 4 POLES - ELECTRONIC IN-LINE PUMPS FOR HEATING, AIR CONDITIONING, REFRIGERATION, SOLAR, AND SANITARY SYSTEMS - TWIN, FLANGED, WITH MCE/C INVERTER

Pumped liquid temperature range: from -10 °C to +140°C - Maximum ambient temperature: +40°C

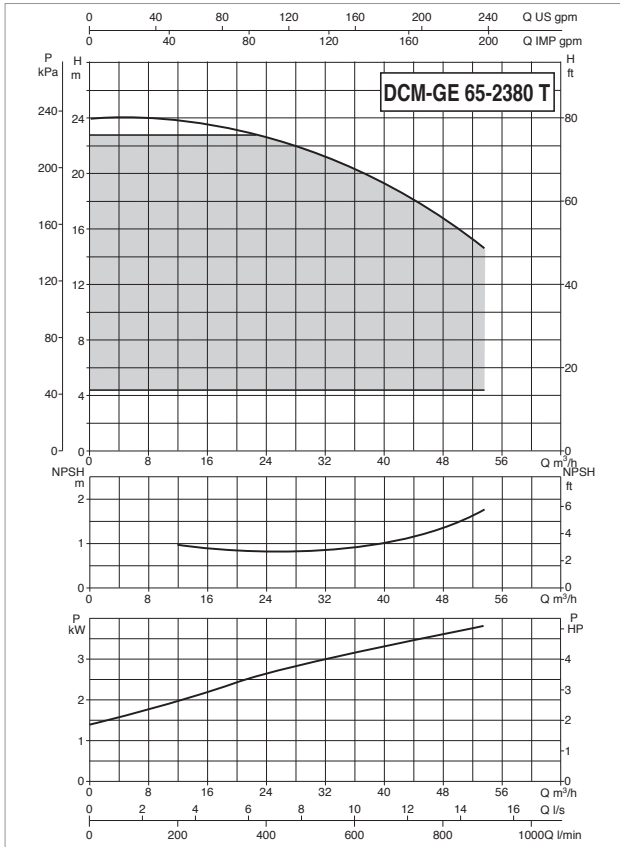

For the MEI index refer to the hydraulic data of the individual pump.

The performance curves are based on kinematic viscosity values = 1 mm²/s and density equal to 1000 kg/m³. Curve tolerance according to ISO 9906.

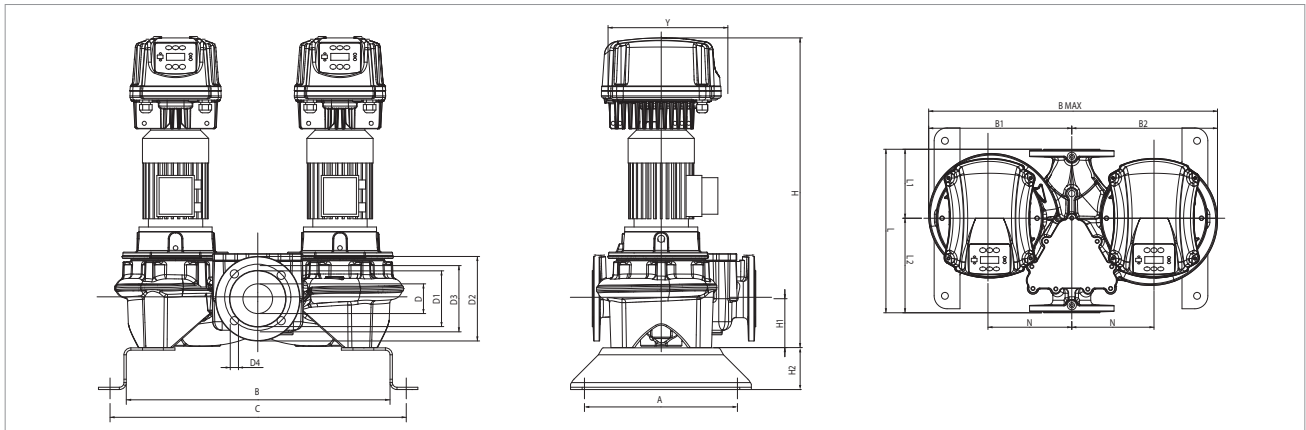

MODEL	ELECTRICAL DATA						
	POWER INPUT 50-60 Hz	MOTOR TYPE	n r.p.m.	P1 MAX W	P2 NOMINAL		In A
					kW	HP	
DCM-GE 65-2380/A/BAQE/ 4 T MCE30/C IE2 *	3x400 V ~	4 poles	1449	4,47	4	5,5	9,5

* ΔP-v proportional differential pressure adjustment mode also available.

MODEL	A	B	C	B1	B2	B max	D1	D2	D3	D4	no. of holes	Y	H	H1	H2	L	L1	L2	M	N	PACKING DIMENSIONS			VOL. (m ³)	WEIGHT kg
																					L/A	L/B	H		
DCM-GE 65-2380/A/BAQE/ 4 T MCE30/C IE2	330	649	719	387	395	782	122	185	145	18	4	352	925	125	100	475	177	298	M16	220	475	782	925	0,34	233

DCM-GE 80 4 POLES - ELECTRONIC IN-LINE PUMPS FOR HEATING, AIR CONDITIONING, REFRIGERATION, SOLAR, AND SANITARY SYSTEMS - TWIN, FLANGED, WITH MCE/C INVERTER

Pumped liquid temperature range: from -10 °C to +140°C - Maximum ambient temperature: +40°C

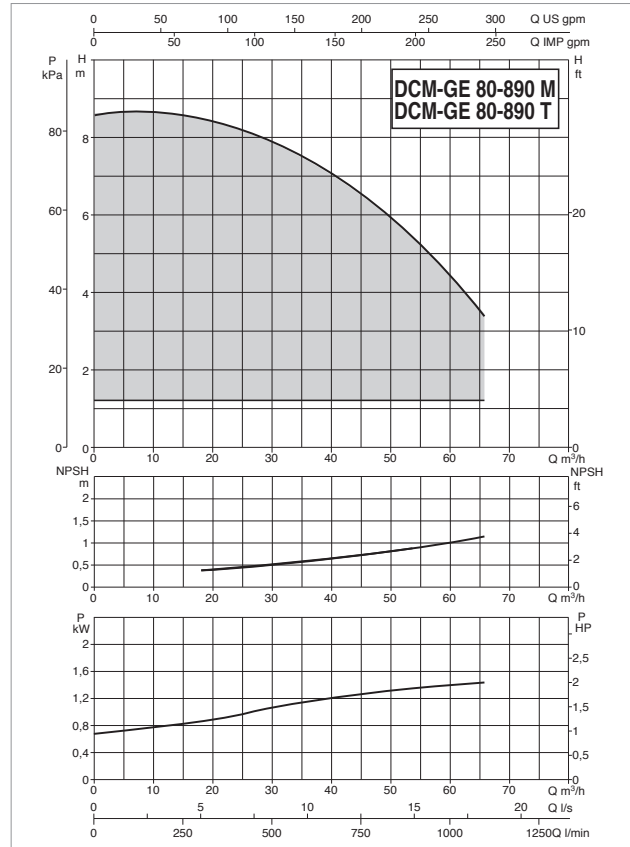
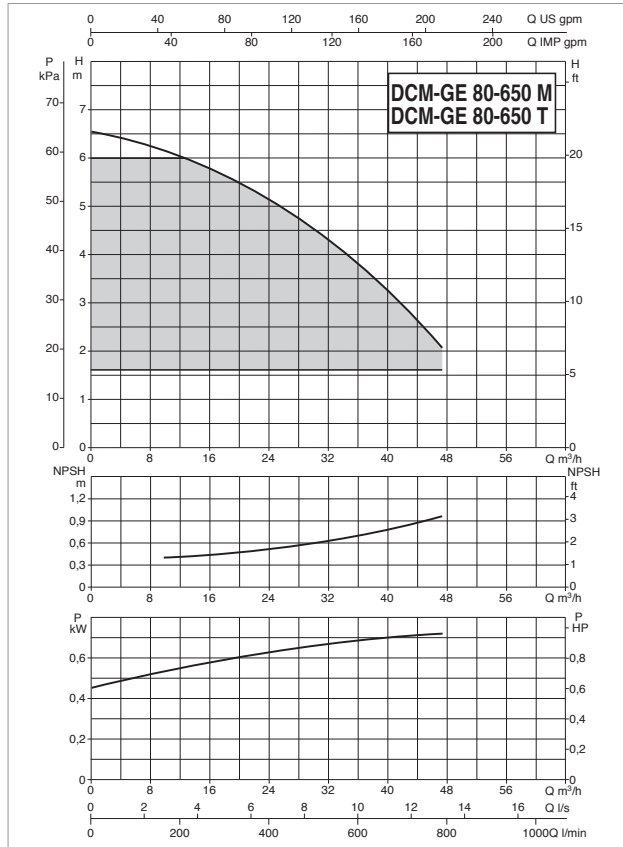

For the MEI index refer to the hydraulic data of the individual pump.

The performance curves are based on kinematic viscosity values = 1 mm²/s and density equal to 1000 kg/m³. Curve tolerance according to ISO 9906.

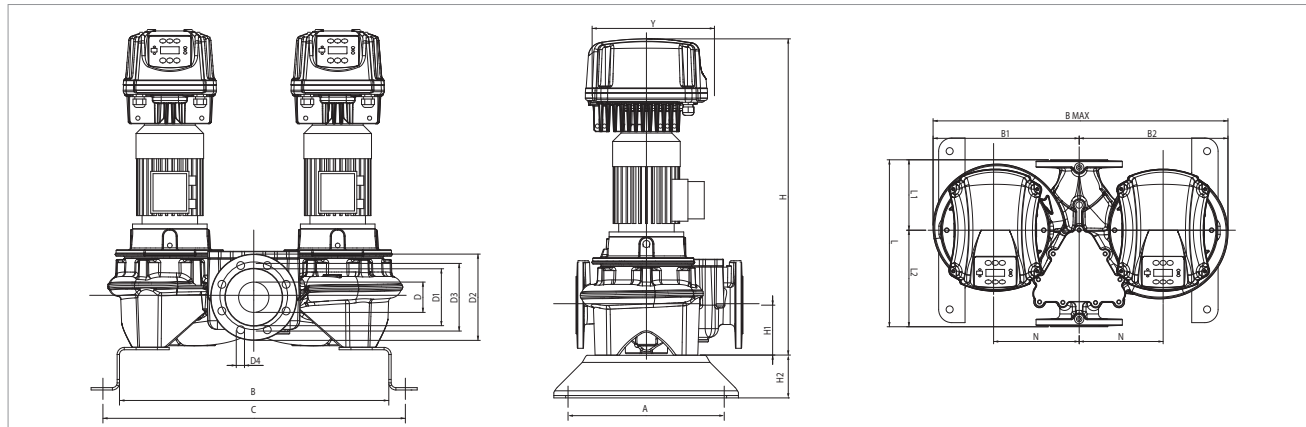

MODEL	ELECTRICAL DATA						
	POWER INPUT 50-60 Hz	MOTOR TYPE	n r.p.m.	P1 MAX W	P2 NOMINAL		I _n A
					kW	HP	
DCM-GE 80- 650/A/BAQE/ 0.75 M MCE11/C IE2	1x220-240 V ~	4 poles	1430	1,24	0,75	1	9,8
DCM-GE 80- 650/A/BAQE/ 0.75 T MCE30/C IE2	3x400 V ~	4 poles	1430	1,24	0,75	1	t.b.d.
DCM-GE 80- 890/A/BAQE/ 1.5 M MCE15/C IE2 *	1x220-240 V ~	4 poles	1430	2,07	1,5	2	15,2
DCM-GE 80- 890/A/BAQE/ 1.5 T MCE30/C IE2 *	3x400 V ~	4 poles	1430	2,07	1,5	2	t.b.d.

* ΔP-v proportional differential pressure adjustment mode also available.

MODEL	A	B	C	B1	B2	B max	D1	D2	D3	D4	no. of holes	Y	H	H1	H2	L	L1	L2	M	N	PACKING DIMENSIONS			VOL. (m ³)	WEIGHT kg
																					L/A	L/B	H		
DCM-GE 80- 650/A/BAQE/ 0.75 M MCE11/C IE2	330	580	650	305	310	615	137	200	160	18	8	262	745	115	100	360	165	195	M16	180	360	615	745	0,16	134
DCM-GE 80- 650/A/BAQE/ 0.75 T MCE30/C IE2	330	580	650	305	310	615	137	200	160	18		262	742	115	100	360	165	195	M16	180	360	615	742	0,16	136
DCM-GE 80- 890/A/BAQE/ 1.5 M MCE15/C IE2	620	620	690	355	365	720	137	200	160	18		262	825	115	100	440	180	260	M16	200	440	720	825	0,26	211
DCM-GE 80- 890/A/BAQE/ 1.5 T MCE30/C IE2	620	620	690	355	365	720	137	200	160	18		262	822	115	100	440	180	260	M16	200	440	720	822	0,26	213

DCM-GE 80 4 POLES - ELECTRONIC IN-LINE PUMPS FOR HEATING, AIR CONDITIONING, REFRIGERATION, SOLAR, AND SANITARY SYSTEMS - TWIN, FLANGED, WITH MCE/C INVERTER

Pumped liquid temperature range: from -10 °C to +140°C - Maximum ambient temperature: +40°C

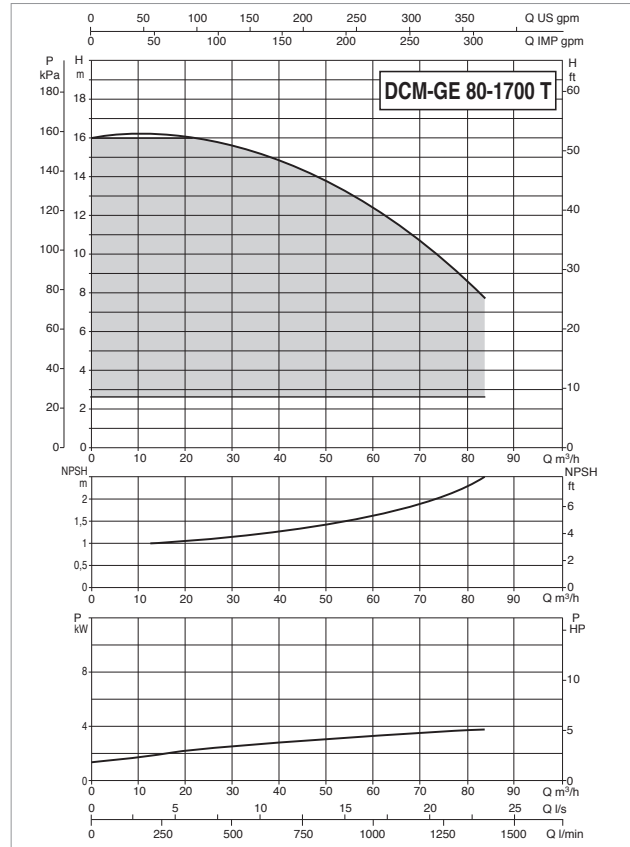
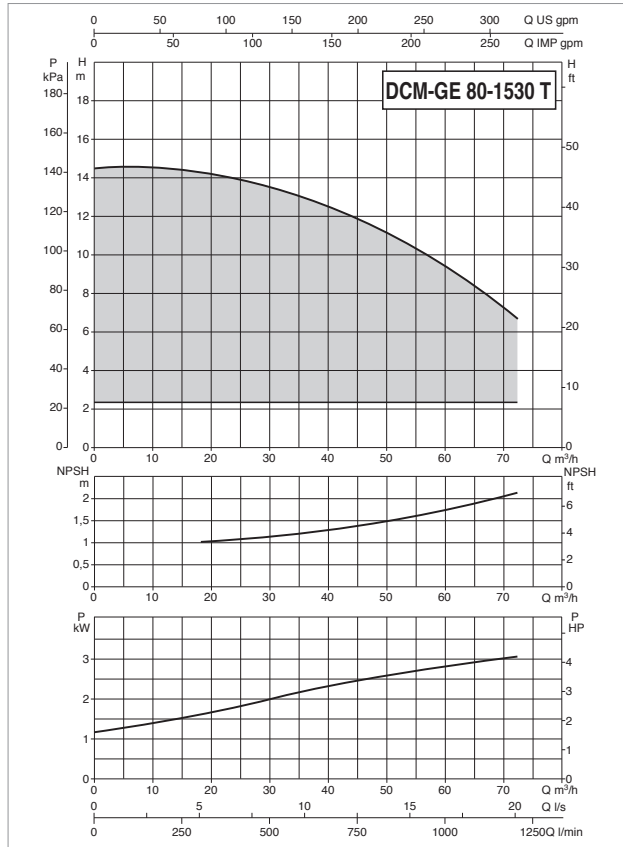

For the MEI index refer to the hydraulic data of the individual pump.

The performance curves are based on kinematic viscosity values = 1 mm²/s and density equal to 1000 kg/m³. Curve tolerance according to ISO 9906.

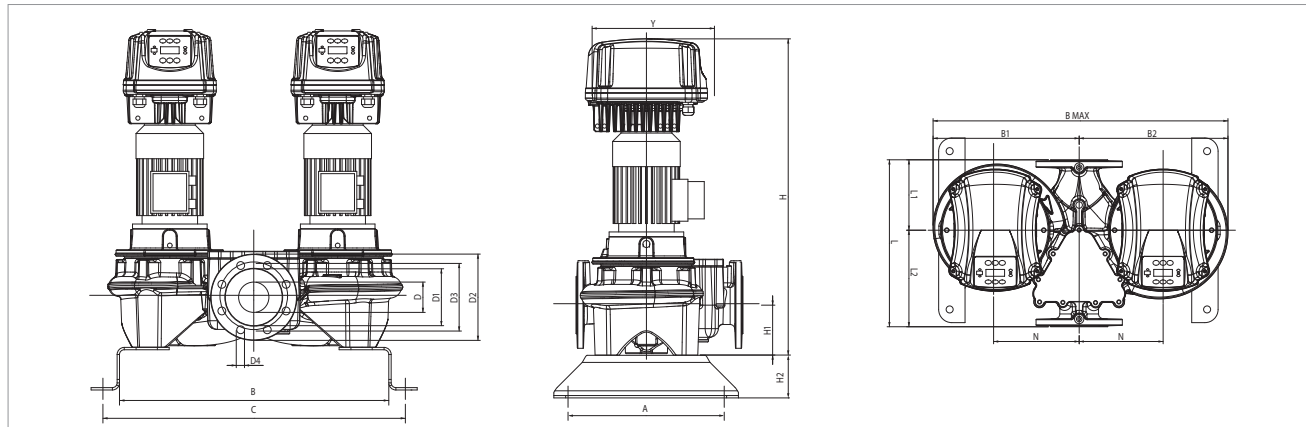

MODEL	ELECTRICAL DATA						
	POWER INPUT 50-60 Hz	MOTOR TYPE	n r.p.m.	P1 MAX W	P2 NOMINAL		In A
					kW	HP	
DCM-GE 80-1530/A/BAQE/ 3 T MCE30/C IE2	3x400 V ~	4 poles	1441	3,74	3	4	8,0
DCM-GE 80-1700/A/BAQE/ 4 T MCE30/C IE2 *		4 poles	1452	4,13	4	5,5	8,9

* ΔP-v proportional differential pressure adjustment mode also available.

MODEL	A	B	C	B1	B2	B max	D1	D2	D3	D4	no. of holes	Y	H	H1	H2	L	L1	L2	M	N	PACKING DIMENSIONS			VOL. (m ³)	WEIGHT kg
																					L/A	L/B	H		
DCM-GE 80-1530/A/BAQE/ 3 T MCE30/C IE2	362	662	690	405	415	820	137	200	160	18	8	352	846	115	100	500	220	280	M16	235	500	820	846	0,35	251
DCM-GE 80-1700/A/BAQE/ 4 T MCE30/C IE2	362	662	732	405	415	820	137	200	160	18		352	931	115	100	500	220	280	M16	235	500	820	931	0,38	277

DCM-GE 80 4 POLES - ELECTRONIC IN-LINE PUMPS FOR HEATING, AIR CONDITIONING, REFRIGERATION, SOLAR, AND SANITARY SYSTEMS - TWIN, FLANGED, WITH MCE/C INVERTER

Pumped liquid temperature range: from -10 °C to +140°C - Maximum ambient temperature: +40°C

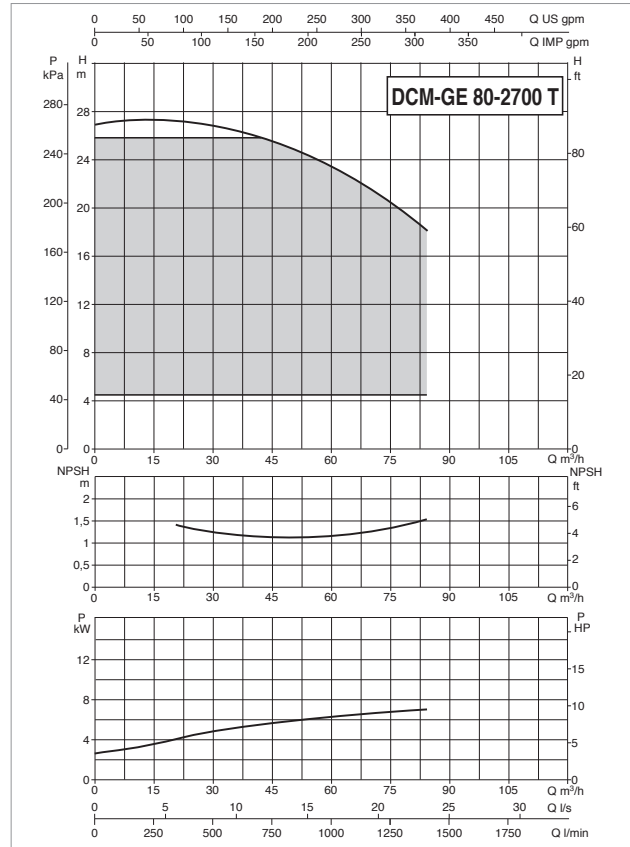
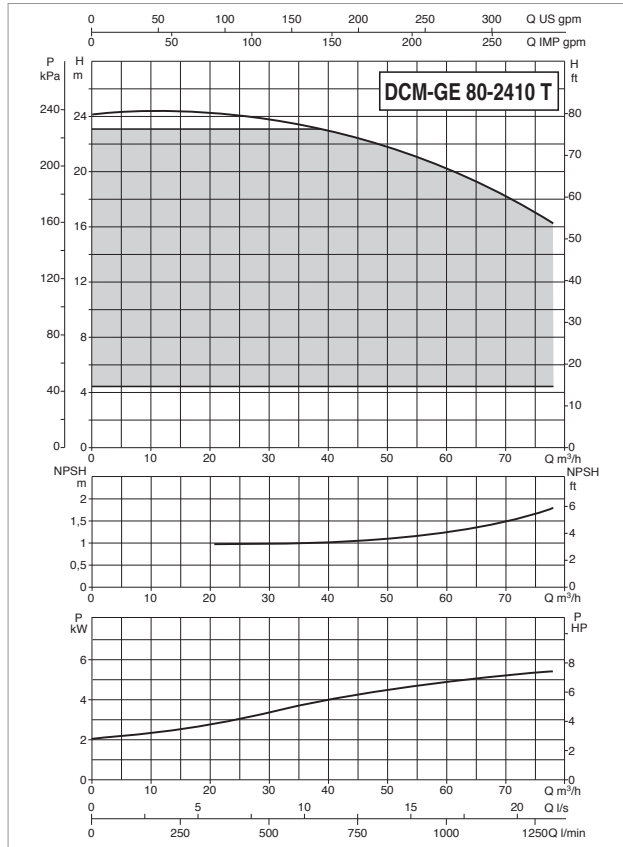

For the MEI index refer to the hydraulic data of the individual pump.

The performance curves are based on kinematic viscosity values = 1 mm²/s and density equal to 1000 kg/m³. Curve tolerance according to ISO 9906.

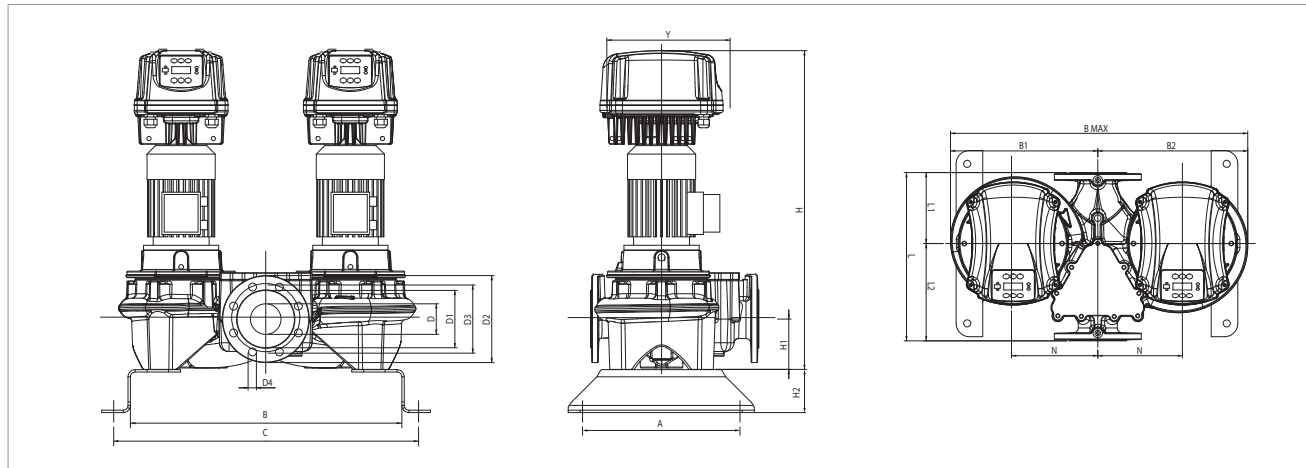

MODEL	ELECTRICAL DATA						
	POWER INPUT 50-60 Hz	MOTOR TYPE	n r.p.m.	P1 MAX W	P2 NOMINAL		In A
					kW	HP	
DCM-GE 80-2410/A/BAQE/ 5.5 T MCE55/C IE2 *	3x400 V ~	4 poles	1461	6,80	5,5	7,5	13,8
DCM-GE 80-2700/A/BAQE/ 7.5 T MCE110/C IE2		4 poles	1463	9,15	7,5	10	18,6

* ΔP-v proportional differential pressure adjustment mode also available.

MODEL	A	B	C	B1	B2	B max	D1	D2	D3	D4	no. of holes	Y	H	H1	H2	L	L1	L2	M	N	PACKING DIMENSIONS			VOL. (m³)	WEIGHT kg
																					L/A	L/B	H		
																					DCM-GE 80-2410/A/BAQE/ 5.5 T MCE55/C IE2	500	804		
DCM-GE 80-2700/A/BAQE/ 7.5 T MCE110/C IE2	500	804	924	530	540	1070	137	200	160	18	425	1087	140	100	620	280	340	M16	300	620	1070	1087	0,72	499	

DCM-GE 80 4 POLES - ELECTRONIC IN-LINE PUMPS FOR HEATING, AIR CONDITIONING, REFRIGERATION, SOLAR, AND SANITARY SYSTEMS - TWIN, FLANGED, WITH MCE/C INVERTER

Pumped liquid temperature range: from -10 °C to +140°C - Maximum ambient temperature: +40°C

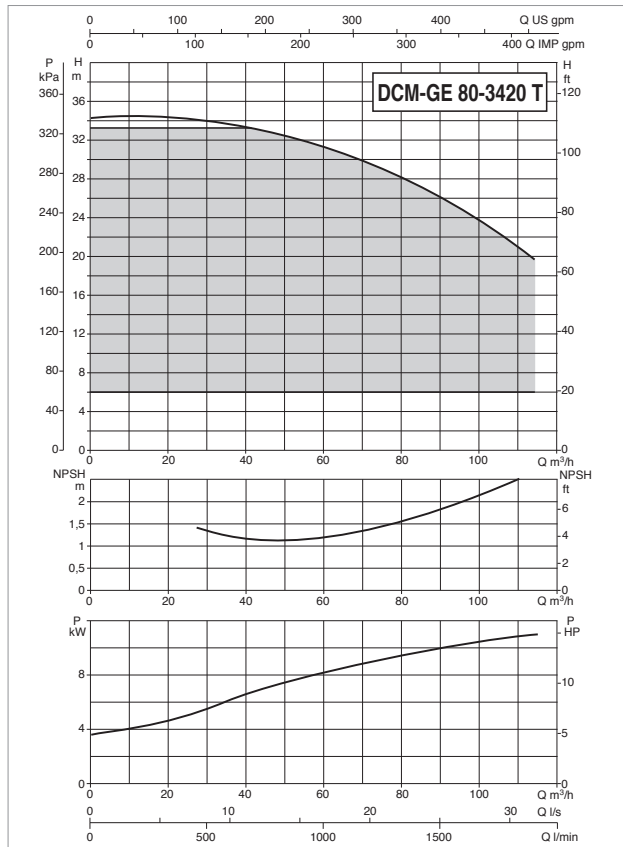

For the MEI index refer to the hydraulic data of the individual pump.

The performance curves are based on kinematic viscosity values = 1 mm²/s and density equal to 1000 kg/m³. Curve tolerance according to ISO 9906.

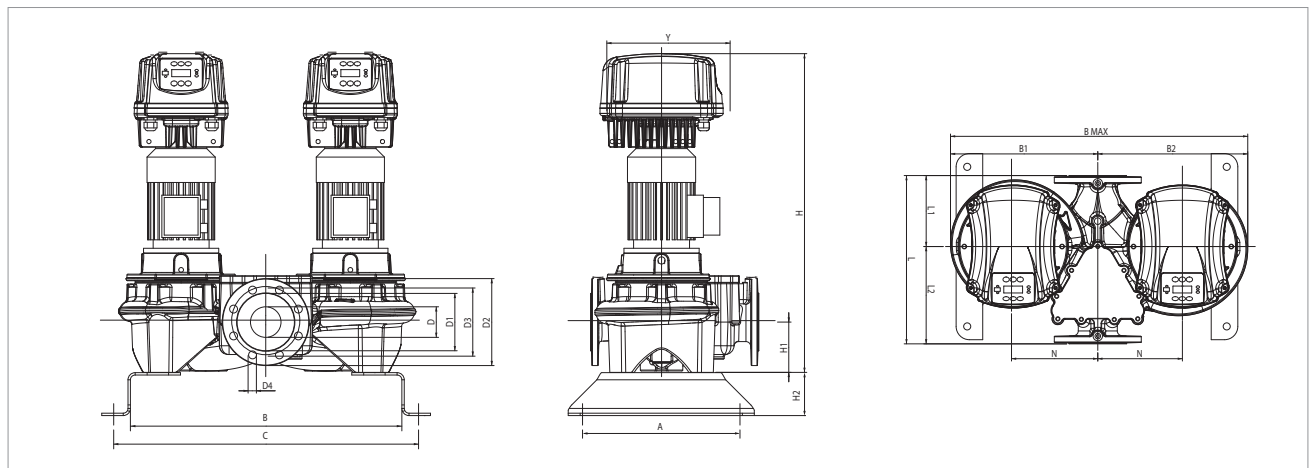

MODEL	ELECTRICAL DATA						
	POWER INPUT 50-60 Hz	MOTOR TYPE	n r.p.m.	P1 MAX W	P2 NOMINAL		In A
					kW	HP	
DCM-GE 80-3420/A/BAQE/ 11 T MCE110/C IE2 *	3x400 V ~	4 poles	1472	13,36	11	15	28,1

* ΔP-v proportional differential pressure adjustment mode also available.

MODEL	A	B	C	B1	B2	B max	D1	D2	D3	D4	no. of holes	Y	H	H1	H2	L	L1	L2	M	N	PACKING DIMENSIONS			VOL. (m ³)	WEIGHT kg
																					L/A	L/B	H		
DCM-GE 80-3420/A/BAQE/ 11 T MCE110/C IE2	500	804	924	530	540	1070	137	200	160	18	8	425	1192	140	100	620	280	340	M16	300	620	1070	1192	0,79	533

DCM-GE 100 4 POLES - ELECTRONIC IN-LINE PUMPS FOR HEATING, AIR CONDITIONING, REFRIGERATION, SOLAR, AND SANITARY SYSTEMS - TWIN, FLANGED, WITH MCE/C INVERTER

Pumped liquid temperature range: from -10 °C to +140°C - Maximum ambient temperature: +40°C

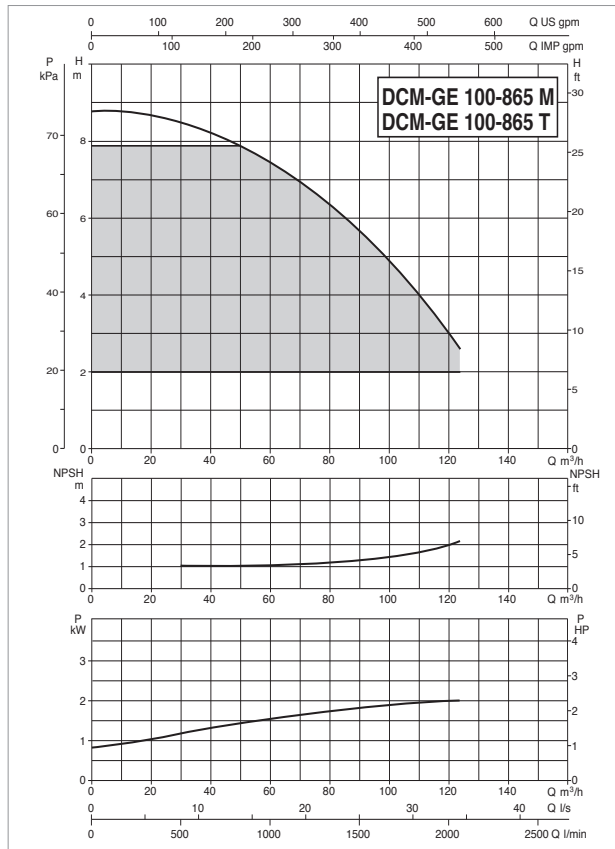
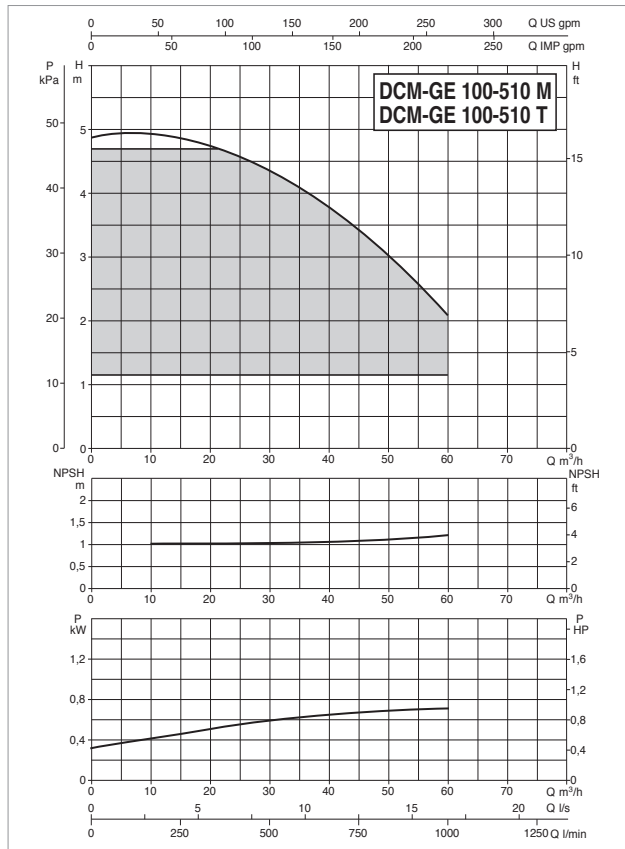

For the MEI index refer to the hydraulic data of the individual pump.

The performance curves are based on kinematic viscosity values = 1 mm²/s and density equal to 1000 kg/m³. Curve tolerance according to ISO 9906.

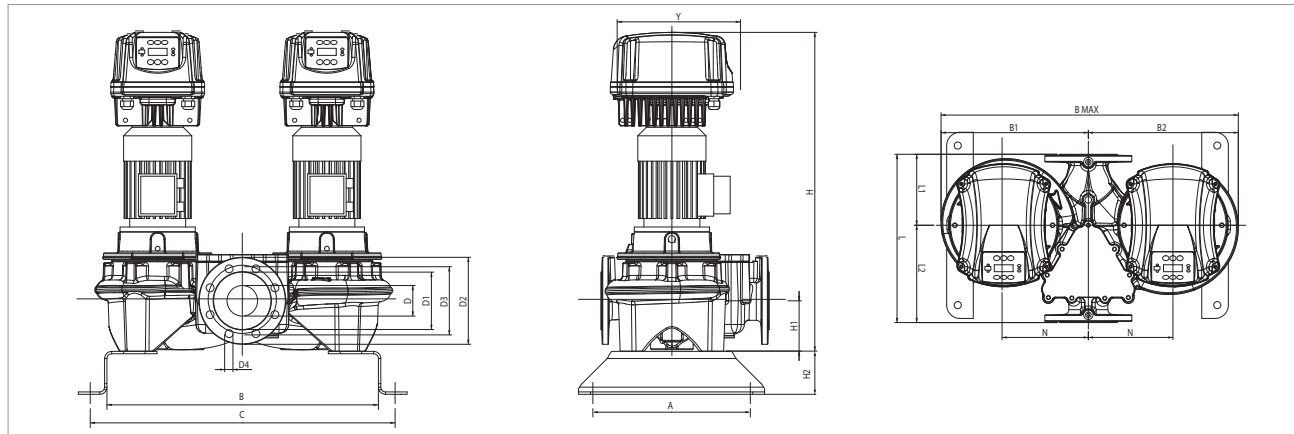

MODEL	ELECTRICAL DATA						
	POWER INPUT 50-60 Hz	MOTOR TYPE	n r.p.m.	P1 MAX W	P2 NOMINAL		In A
					kW	HP	
DCM-GE 100- 510/A/BAQE/ 0.75 M MCE11/C IE2 *	1x220-240 V ~	4 poles	1430	1,21	0,75	1	9,7
DCM-GE 100- 510/A/BAQE/ 0.75 T MCE30/C IE2 *	3x400 V ~	4 poles	1430	1,21	0,75	1	t.b.d.
DCM-GE 100- 865/A/BAQE/ 2.2 M MCE22/C IE2 *	1x220-240 V ~	4 poles	1430	2,94	2,2	3	20,7
DCM-GE 100- 865/A/BAQE/ 2.2 T MCE30/C IE2 *	3x400 V ~	4 poles	1430	2,94	2,2	3	7,0

* ΔP-v proportional differential pressure adjustment mode also available.

MODEL	A	B	C	B1	B2	B max	D1	D2	D3	D4	no. of holes	Y	H	H1	H2	L	L1	L2	M	N	PACKING DIMENSIONS			VOL. (m³)	WEIGHT kg
																					L/A	L/B	H		
DCM-GE 100- 510/A/BAQE/ 0.75 M MCE11/C IE2	362	637	717	330	345	675	156	220	180	18	8	262	772	140	100	500	191	309	M16	200	500	675	772	0,26	218
DCM-GE 100- 510/A/BAQE/ 0.75 T MCE30/C IE2	362	637	717	330	345	675	156	220	180	18		262	769	140	100	500	191	309	M16	200	500	675	769	0,26	220
DCM-GE 100- 865/A/BAQE/ 1.5 M MCE22/C IE2	362	733	813	395	410	805	156	220	180	18		352	847	140	100	550	221	329	M16	235	550	805	847	0,38	253
DCM-GE 100- 865/A/BAQE/ 1.5 T MCE22/C IE2	362	733	813	395	410	805	156	220	180	18		262	847	140	100	550	221	329	M16	235	550	805	847	0,38	251

DCM-GE 100 4 POLES - ELECTRONIC IN-LINE PUMPS FOR HEATING, AIR CONDITIONING, REFRIGERATION, SOLAR, AND SANITARY SYSTEMS - TWIN, FLANGED, WITH MCE/C INVERTER

Pumped liquid temperature range: from -10 °C to +140°C - Maximum ambient temperature: +40°C

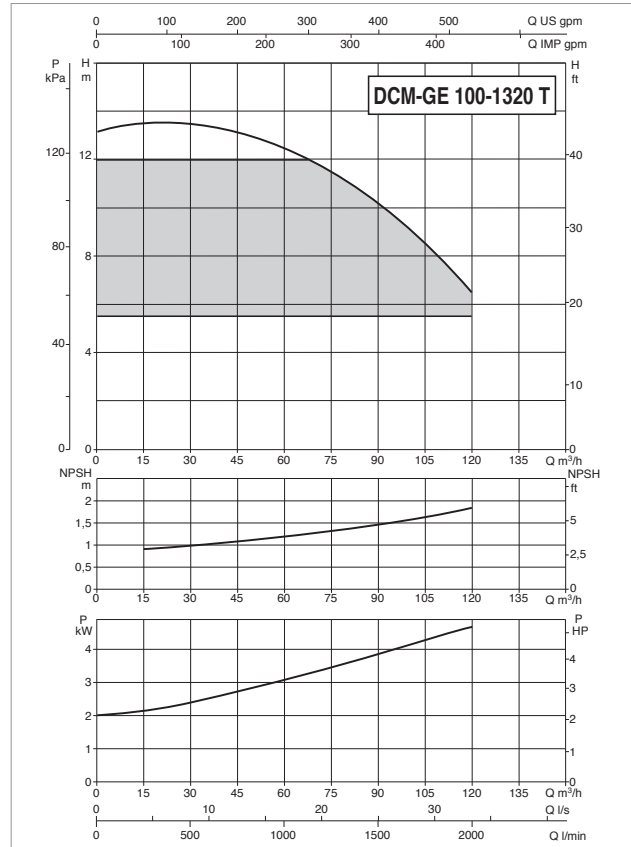
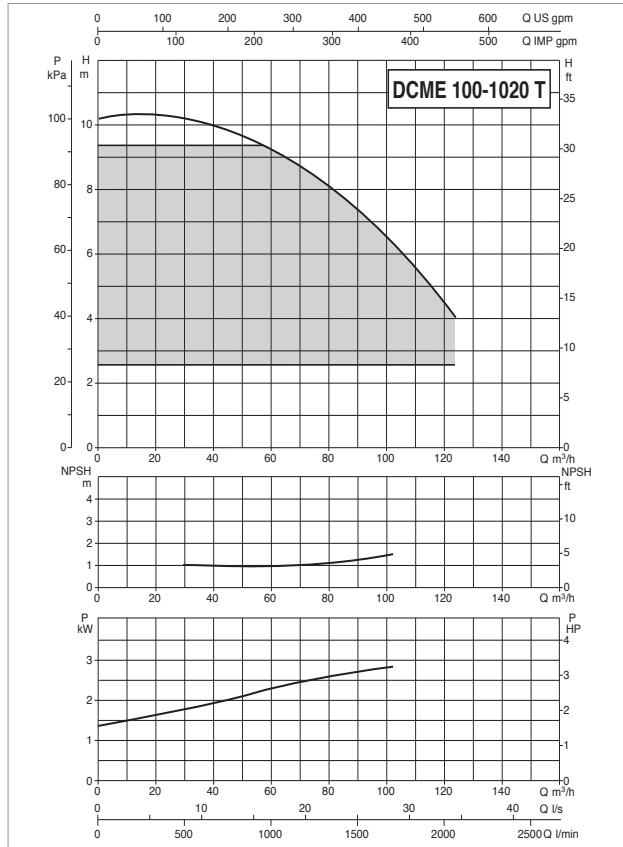

For the MEI index refer to the hydraulic data of the individual pump.

The performance curves are based on kinematic viscosity values = 1 mm²/s and density equal to 1000 kg/m³. Curve tolerance according to ISO 9906.

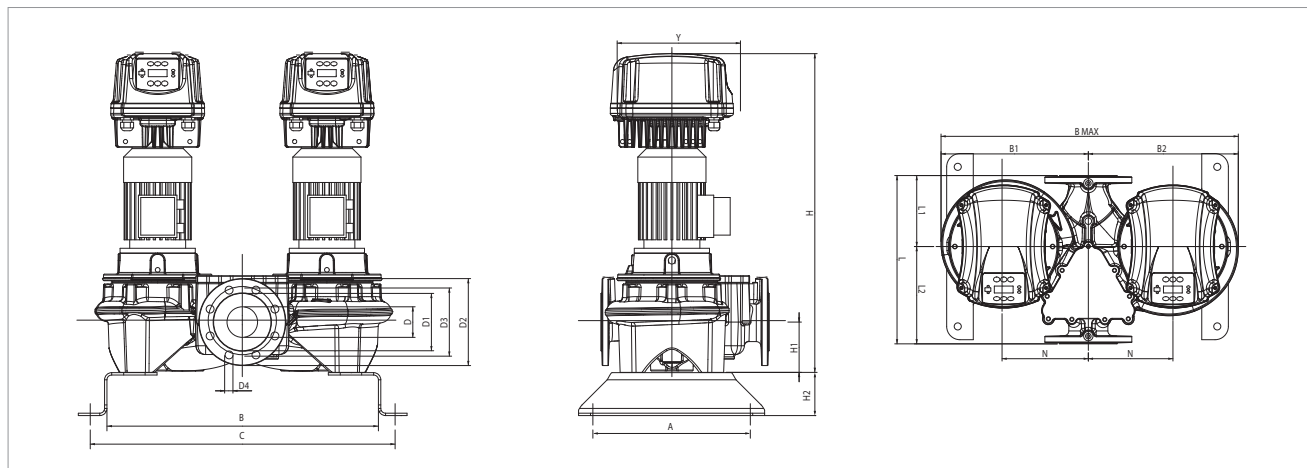

MODEL	ELECTRICAL DATA						
	POWER INPUT 50-60 Hz	MOTOR TYPE	n r.p.m.	P1 MAX W	P2 NOMINAL		In A
					kW	HP	
DCM-GE 100-1020/A/BAQE/ 3 T MCE30/C IE2 *	3x400 V ~	4 poles	1441	3,77	3	4	8,1
DCM-GE 100-1320/A/BAQE/4 T MCE55/C IE2 *		4 poles	1450	4,81	4	5,5	10

* ΔP-v proportional differential pressure adjustment mode also available.

MODEL	A	B	C	B1	B2	B max	D1	D2	D3	D4	no. of holes	Y	H	H1	H2	L	L1	L2	M	N	PACKING DIMENSIONS			VOL. (m ³)	WEIGHT kg
																					L/A	L/B	H		
																					DCM-GE 100-1020/A/BAQE/ 3 T MCE30/C IE2	362	733		
DCM-GE 100-1320/A/BAQE/4 T MCE55/C IE2	362	753	833	430	440	870	156	220	180	18	352	1007	140	100	550	221	329	M16	250	550	870	1007	0,48	308	

DCM-GE 100 4 POLES - ELECTRONIC IN-LINE PUMPS FOR HEATING, AIR CONDITIONING, REFRIGERATION, SOLAR, AND SANITARY SYSTEMS - TWIN, FLANGED, WITH MCE/C INVERTER

Pumped liquid temperature range: from -10 °C to +140°C - Maximum ambient temperature: +40°C

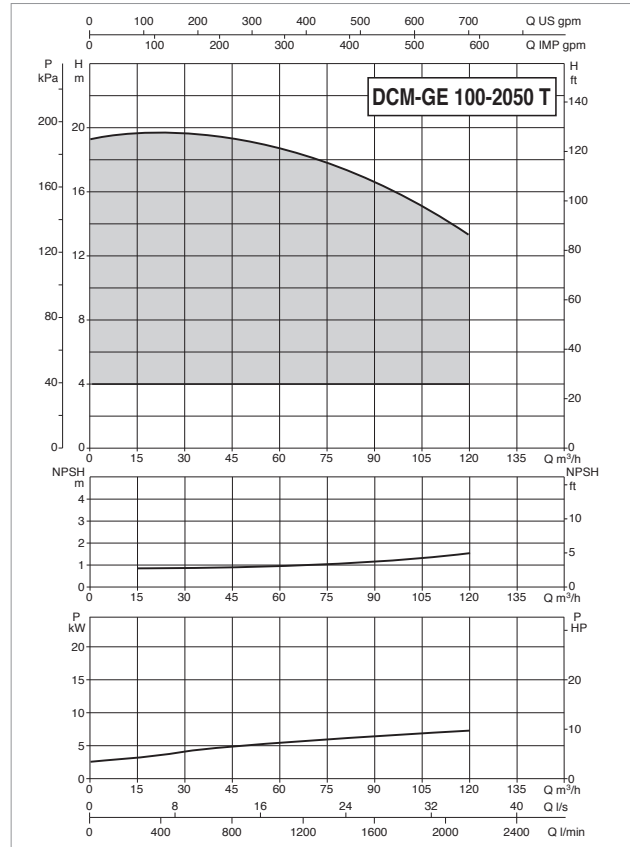
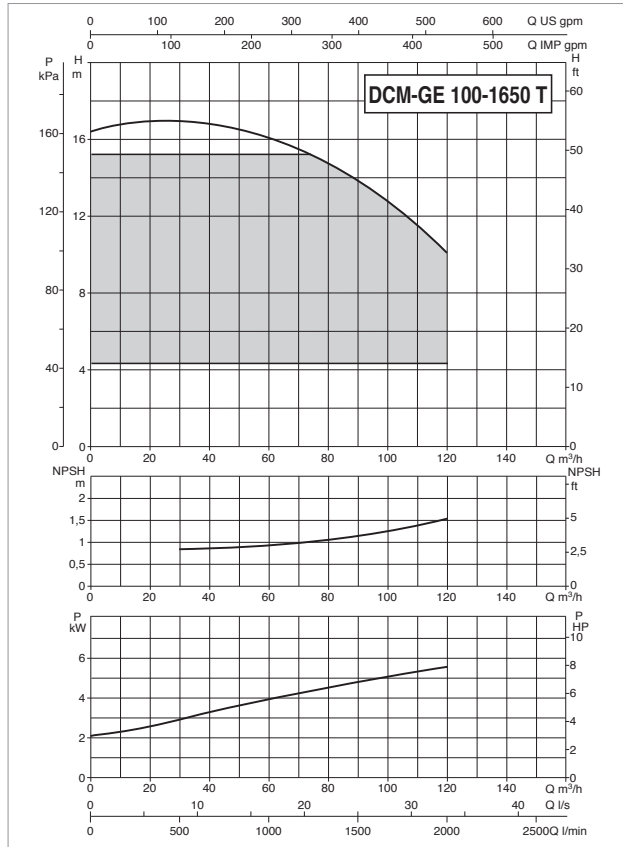

For the MEI index refer to the hydraulic data of the individual pump.

The performance curves are based on kinematic viscosity values = 1 mm²/s and density equal to 1000 kg/m³. Curve tolerance according to ISO 9906.

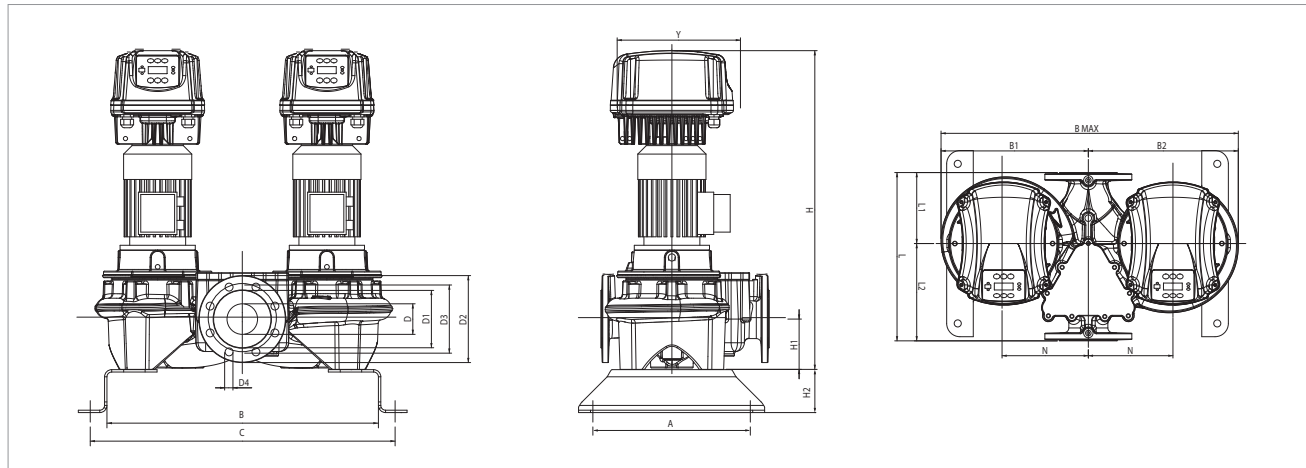

MODEL	ELECTRICAL DATA						
	POWER INPUT 50-60 Hz	MOTOR TYPE	n r.p.m.	P1 MAX W	P2 NOMINAL		In A
					kW	HP	
DCM-GE 100-1650/A/BAQE/ 5.5 T MCE55/C IE2 *	3x400 V ~	4 poles	1464	7,27	5,5	7,5	14,6
DCM-GE 100-2050/A/BAQE/ 7.5 T MCE110/C IE2		4 poles	1461	8,89	7,5	10	18,1

* ΔP-v proportional differential pressure adjustment mode also available.

MODEL	A	B	C	B1	B2	B max	D1	D2	D3	D4	no. of holes	Y	H	H1	H2	L	L1	L2	M	N	PACKING DIMENSIONS			VOL. (m³)	WEIGHT kg
																					L/A	L/B	H		
																					DCM-GE 100-1650/A/BAQE/ 5.5 T MCE55/C IE2	362	753		
DCM-GE 100-2050/A/BAQE/ 7.5 T MCE110/C IE2	500	836	956	560	575	1135	156	220	180	18	8	425	1132	175	100	670	266	404	M16	300	670	1135	1132	0,86	558

DCM-GE 100 4 POLES - ELECTRONIC IN-LINE PUMPS FOR HEATING, AIR CONDITIONING, REFRIGERATION, SOLAR, AND SANITARY SYSTEMS - TWIN, FLANGED, WITH MCE/C INVERTER

Pumped liquid temperature range: from -10 °C to +140°C - Maximum ambient temperature: +40°C

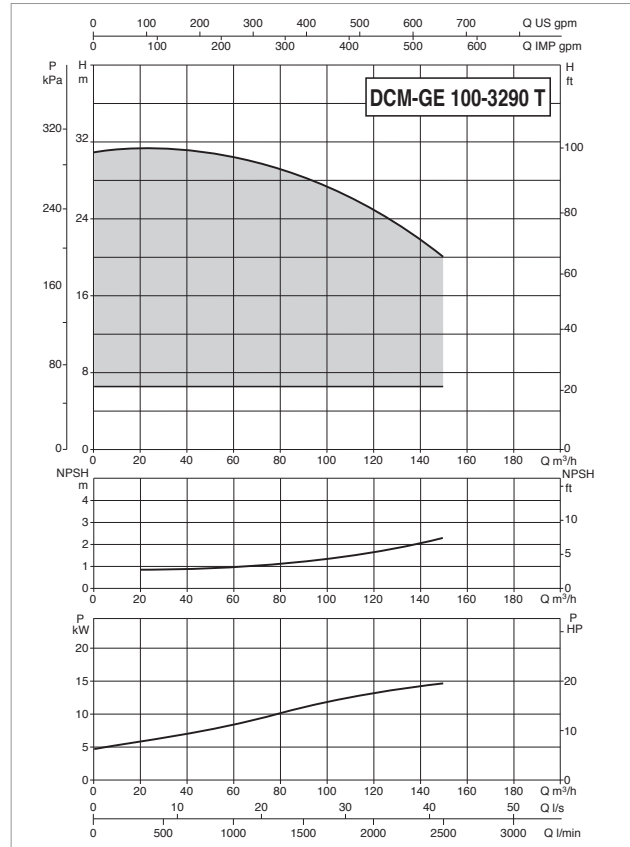
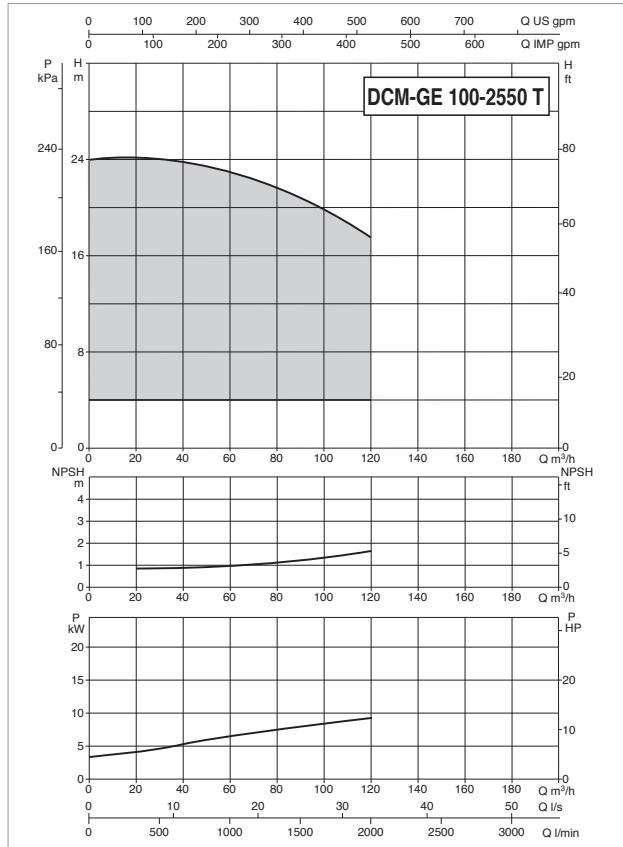

For the MEI index refer to the hydraulic data of the individual pump.

The performance curves are based on kinematic viscosity values = 1 mm²/s and density equal to 1000 kg/m³. Curve tolerance according to ISO 9906.

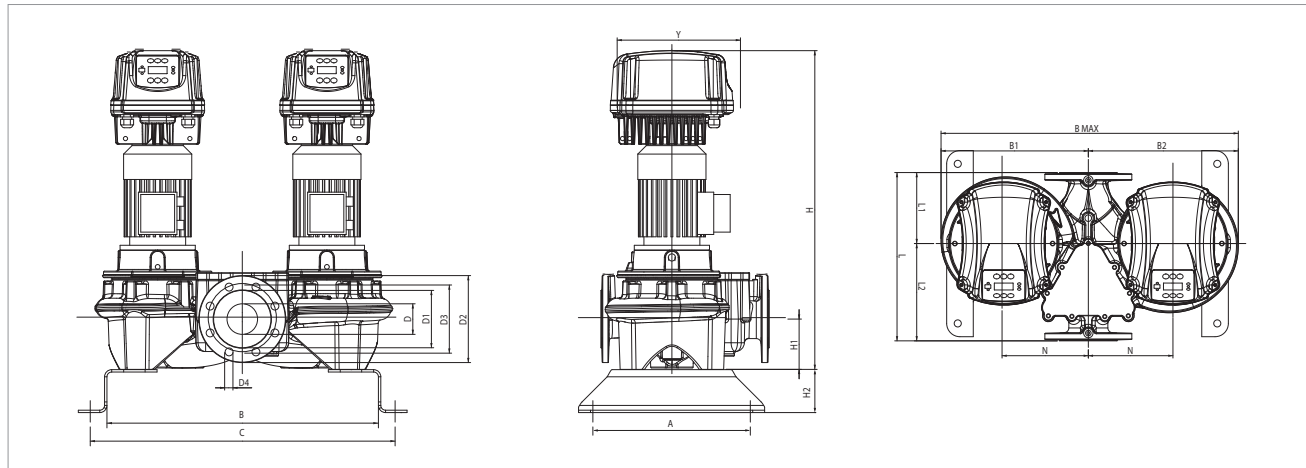

MODEL	ELECTRICAL DATA						
	POWER INPUT 50-60 Hz	MOTOR TYPE	n r.p.m.	P1 MAX W	P2 NOMINAL		In A
					kW	HP	
DCM-GE 100-2550/A/BAQE/ 11 T MCE110/C IE2 *	3x400 V ~	4 poles	1470	12,74	11	15	27
DCM-GE 100-3290/A/BAQE/ 15 T MCE150/C IE2		4 poles	1471	17,91	15	20	37,1

* ΔP-v proportional differential pressure adjustment mode also available.

MODEL	A	B	C	B1	B2	B max	D1	D2	D3	D4	no. of holes	Y	H	H1	H2	L	L1	L2	M	N	PACKING DIMENSIONS			VOL. (m ³)	WEIGHT kg
																					L/A	L/B	H		
DCM-GE 100-2550/A/BAQE/ 11 T MCE110/C IE2	500	836	956	560	575	1135	156	220	180	18	8	425	1237	175	100	670	266	404	M16	300	670	1135	1237	0,94	565
DCM-GE 100-3290/A/BAQE/ 15 T MCE150/C IE2	500	836	956	560	575	1135	156	220	180	18		425	1292	175	100	670	266	404	M16	300	670	1135	1292	0,98	753

DCM-GE 125 4 POLES - ELECTRONIC IN-LINE PUMPS FOR HEATING, AIR CONDITIONING, REFRIGERATION, SOLAR, AND SANITARY SYSTEMS - TWIN, FLANGED, WITH MCE/C INVERTER

Pumped liquid temperature range: from -10 °C to +140°C - Maximum ambient temperature: +40°C

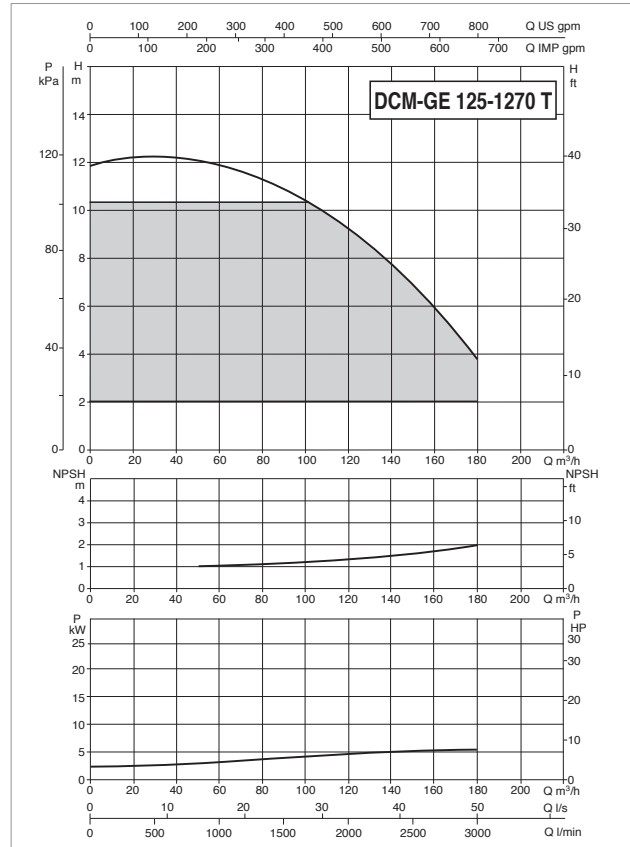
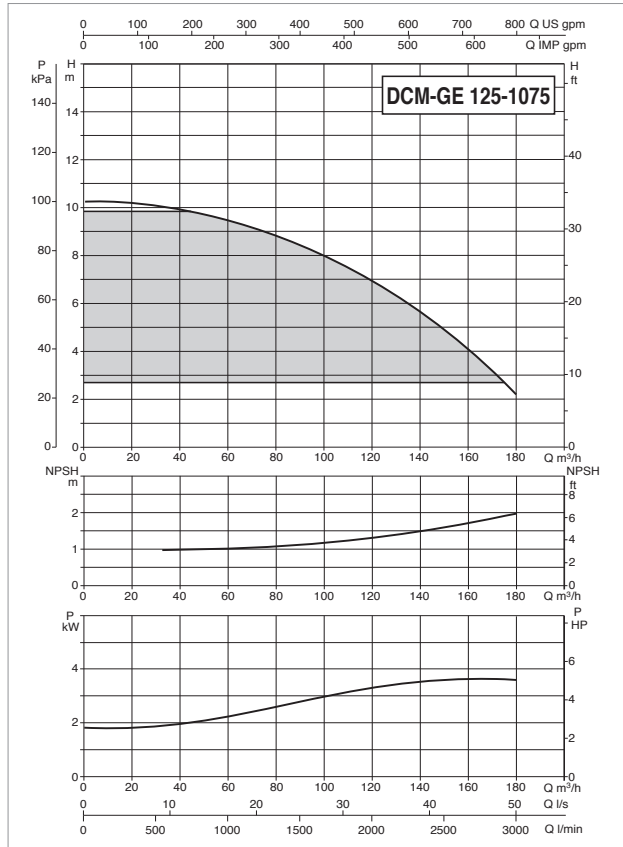

For the MEI index refer to the hydraulic data of the individual pump.

The performance curves are based on kinematic viscosity values = 1 mm²/s and density equal to 1000 kg/m³. Curve tolerance according to ISO 9906.

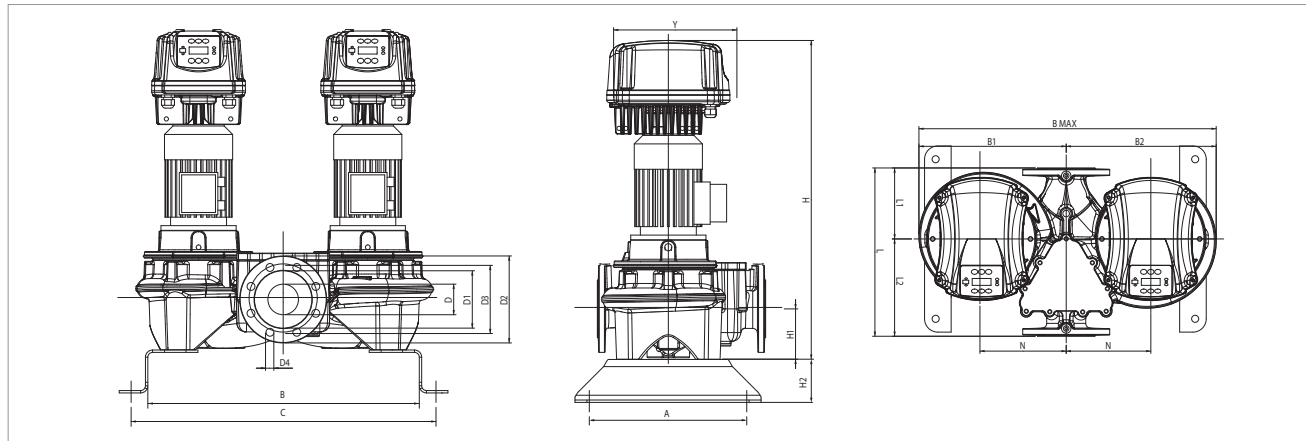

MODEL	ELECTRICAL DATA						
	POWER INPUT 50-60 Hz	MOTOR TYPE	n r.p.m.	P1 MAX W	P2 NOMINAL		In A
					kW	HP	
DCM-GE 125-1075/A/BAQE/ 4 T MCE55/C IE2	3x400 V ~	4 poles	1455	5,38	4	5,5	11
DCM-GE 125-1270/A/BAQE/ 5.5 T MCE55/C IE2 *		4 poles	1465	7,55	5,5	7,5	15,2

* ΔP-v proportional differential pressure adjustment mode also available.

MODEL	A	B	C	B1	B2	B max	D1	D2	D3	D4	no. of holes	Y	H	H1	H2	L	L1	L2	M	N	PACKING DIMENSIONS			VOL. (m ³)	WEIGHT kg
																					L/A	L/B	H		
																					DCM-GE 125-1075/A/BAQE/ 4 T MCE55/C IE2	500	810		
DCM-GE 125-1270/A/BAQE/ 5.5 T MCE55/C IE2	500	810	930	515	535	1050	185	250	210	14	8	352	1089	215	100	620	226	394	M16	300	620	1050	1089	0,71	503

DCM-GE 125 4 POLES - ELECTRONIC IN-LINE PUMPS FOR HEATING, AIR CONDITIONING, REFRIGERATION, SOLAR, AND SANITARY SYSTEMS - TWIN, FLANGED, WITH MCE/C INVERTER

Pumped liquid temperature range: from -10 °C to +140°C - Maximum ambient temperature: +40°C

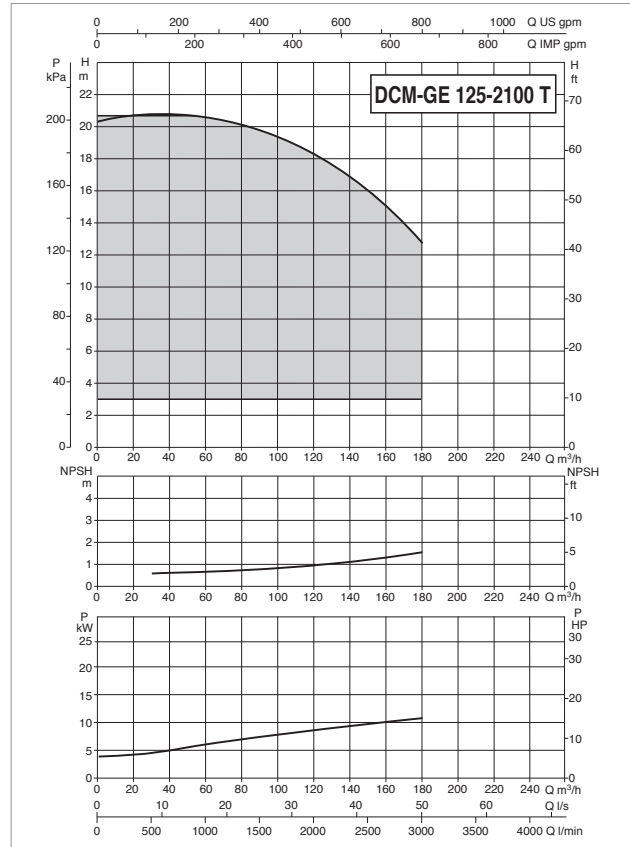
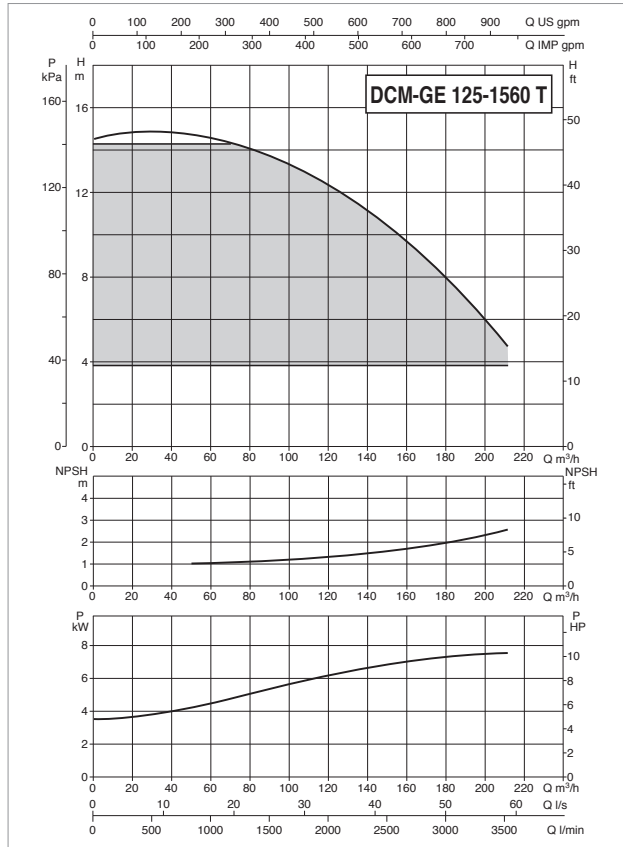

For the MEI index refer to the hydraulic data of the individual pump.

The performance curves are based on kinematic viscosity values = 1 mm²/s and density equal to 1000 kg/m³. Curve tolerance according to ISO 9906.

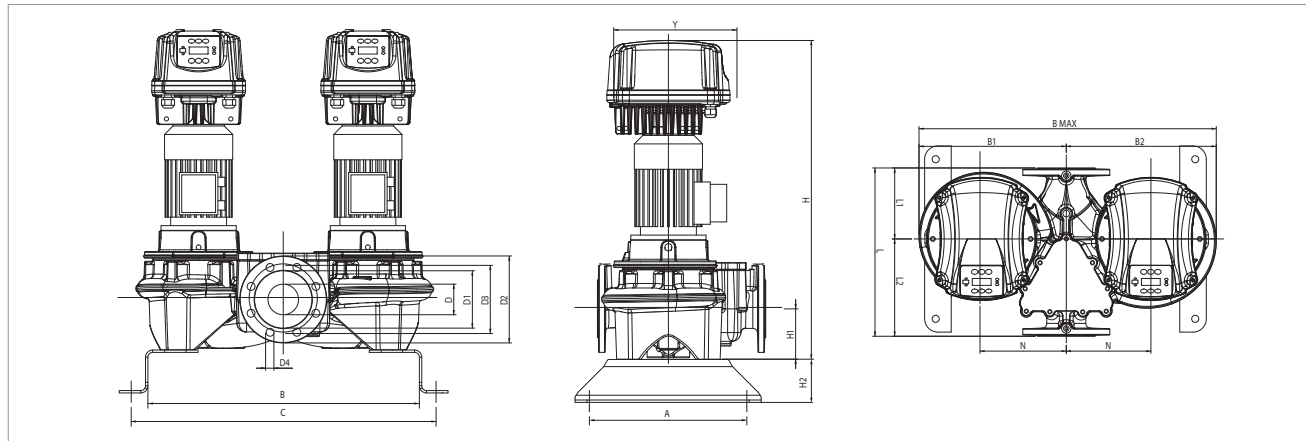

MODEL	ELECTRICAL DATA						
	POWER INPUT 50-60 Hz	MOTOR TYPE	n r.p.m.	P1 MAX W	P2 NOMINAL		In A
					kW	HP	
DCM-GE 125-1560/A/BAQE/ 7.5 T MCE110/C IE2 *	3x400 V ~	4 poles	1469	9,93	7,5	10	20,0
DCM-GE 125-2100/A/BAQE/ 11 T MCE110/C IE2		4 poles	1475	14,30	11	15	29,8

* ΔP-v proportional differential pressure adjustment mode also available.

MODEL	A	B	C	B1	B2	B max	D1	D2	D3	D4	no. of holes	Y	H	H1	H2	L	L1	L2	M	N	PACKING DIMENSIONS			VOL. (m ³)	WEIGHT kg
																					L/A	L/B	H		
DCM-GE 125-1560/A/BAQE/ 7.5 T MCE110/C IE2	500	810	930	515	535	1050	185	250	210	14	8	425	1177	215	100	620	226	394	M16	300	620	1050	1177	0,77	538
DCM-GE 125-2100/A/BAQE/ 11 T MCE110/C IE2	500	810	930	555	571	1126	185	250	210	14		425	1297	215	100	800	316	484	M16	300	800	1126	1297	1,17	768

DCM-GE 125 4 POLES - ELECTRONIC IN-LINE PUMPS FOR HEATING, AIR CONDITIONING, REFRIGERATION, SOLAR, AND SANITARY SYSTEMS - TWIN, FLANGED, WITH MCE/C INVERTER

Pumped liquid temperature range: from -10 °C to +140°C - Maximum ambient temperature: +40°C

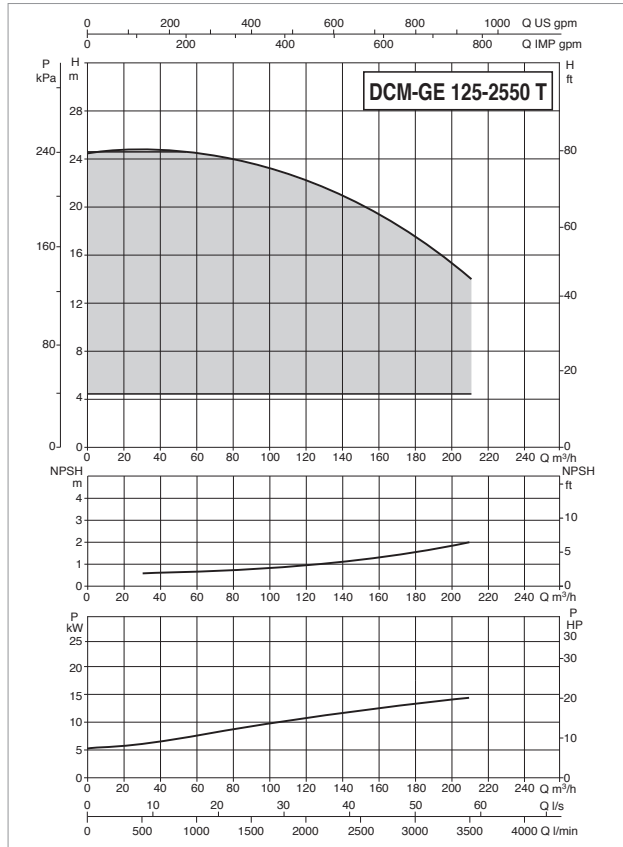

For the MEI index refer to the hydraulic data of the individual pump.

The performance curves are based on kinematic viscosity values = 1 mm²/s and density equal to 1000 kg/m³. Curve tolerance according to ISO 9906.

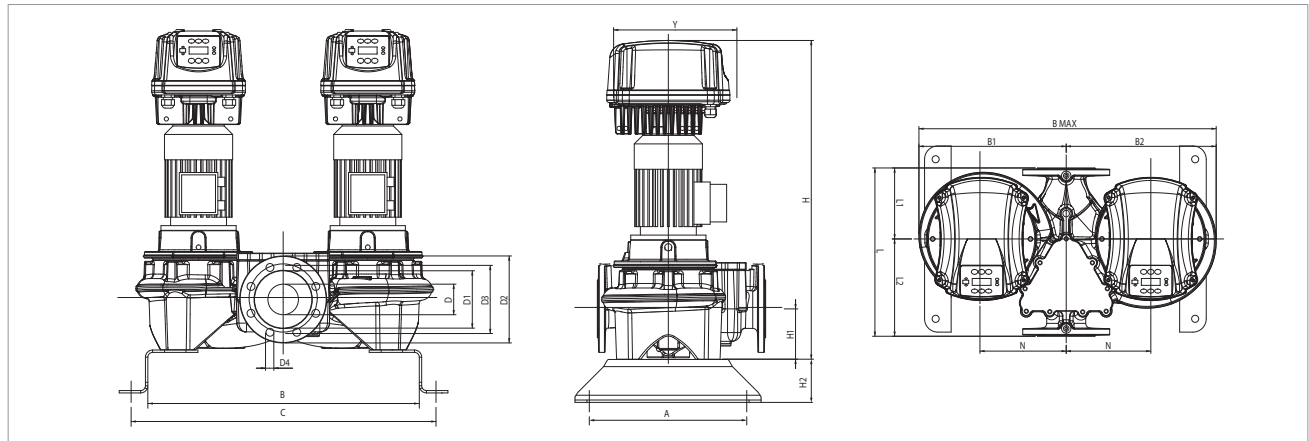

MODEL	ELECTRICAL DATA						
	POWER INPUT 50-60 Hz	MOTOR TYPE	n r.p.m.	P1 MAX W	P2 NOMINAL		In A
					kW	HP	
DCM-GE 125-2550/A/BAQE/ 15 T MCE150/C IE2 *	3x400 V ~	4 poles	1470	17,07	15	20	35,6

* ΔP-v proportional differential pressure adjustment mode also available.

MODEL	A	B	C	B1	B2	B max	D1	D2	D3	D4	no. of holes	Y	H	H1	H2	L	L1	L2	M	N	PACKING DIMENSIONS			VOL. (m³)	WEIGHT kg
																					L/A	L/B	H		
DCM-GE 125-2550/A/BAQE/ 15 T MCE150/C IE2	500	810	930	555	571	1126	185	250	210	14	8	425	1352	215	100	800	316	484	M16	300	800	1126	1352	1,22	880

DCM-GE 150 4 POLES - ELECTRONIC IN-LINE PUMPS FOR CIRCULATION SYSTEMS TWIN, FLANGED, WITH MCE/C INVERTER

Pumped liquid temperature range: from -10 °C to +140°C - Maximum ambient temperature: +40°C

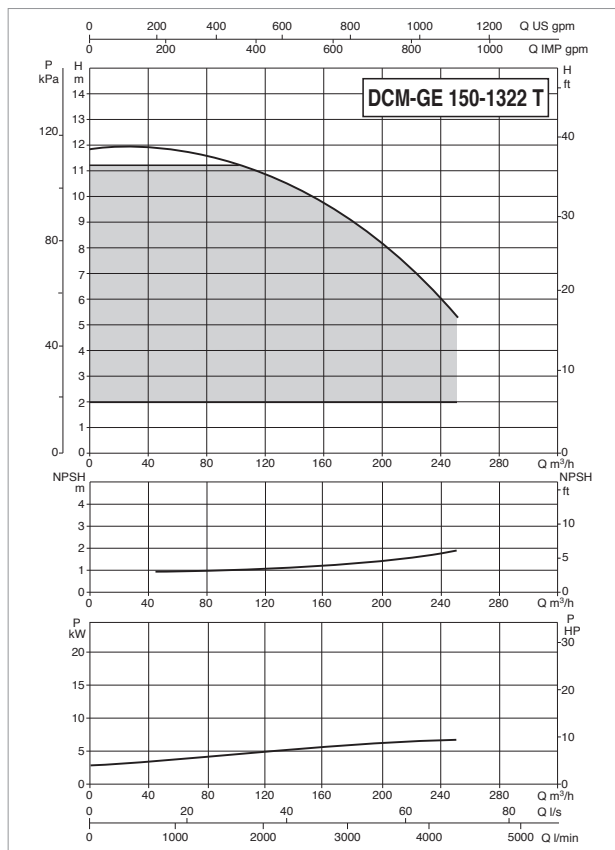
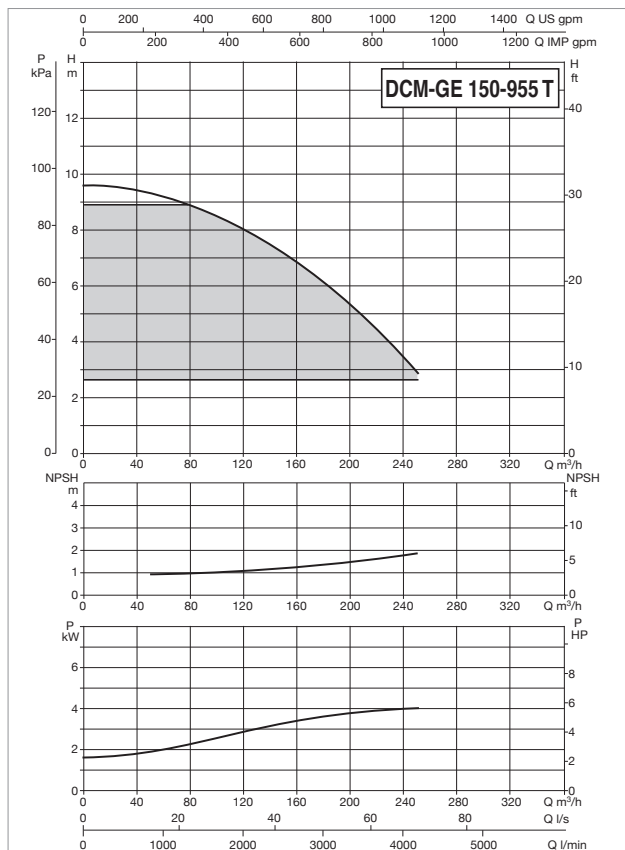

For the MEI index refer to the hydraulic data of the individual pump.

The performance curves are based on kinematic viscosity values = 1 mm²/s and density equal to 1000 kg/m³. Curve tolerance according to ISO 9906.

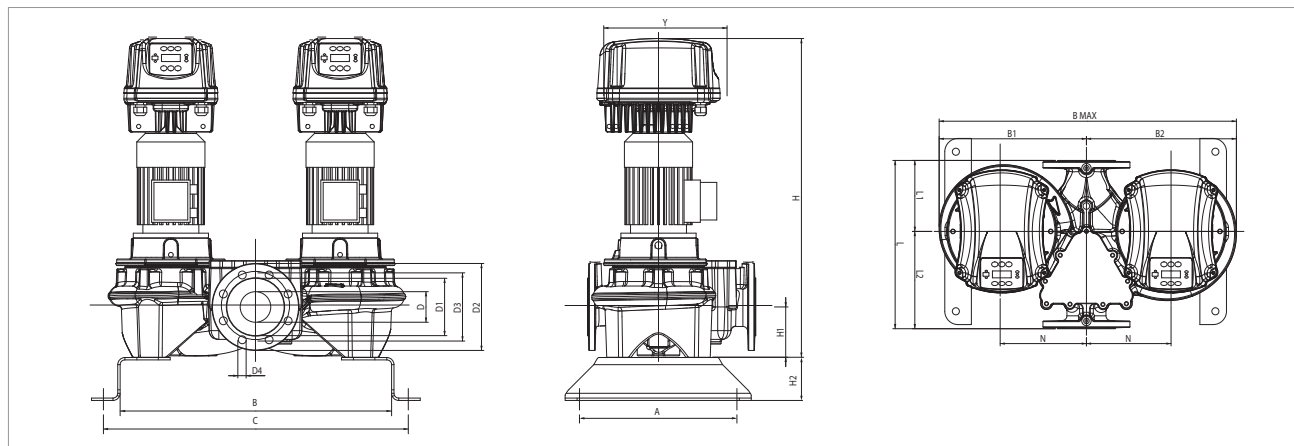

MODEL	ELECTRICAL DATA						
	POWER INPUT 50-60 Hz	MOTOR TYPE	n r.p.m.	P1 MAX W	P2 NOMINAL		In A
					kW	HP	
DCM-GE 150- 955/A/BAQE/ 5.5 T MCE55/C IE2	3x400 V ~	4 poles	1460	7,55	5,5	7,5	15,5
DCM-GE 150-1322/A/BAQE/ 7.5 T MCE110/C IE2		4 poles	1460	9,86	7,5	10	19,5

MODEL	A	B	C	B1	B2	B max	D1	D2	D3	D4	no. of holes	Y	H	H1	H2	L	L1	L2	M	N	PACKING DIMENSIONS			VOL. (m ³)	WEIGHT kg
																					L/A	L/B	H		
DCM-GE 150- 955/A/BAQE/ 5.5 T MCE55/C IE2	500	805	925	550	580	1130	210	285	240	22	8	352	1112	215	100	800	296	504	M16	300	800	1130	1112	1,01	658
DCM-GE 150-1322/A/BAQE/ 7.5 T MCE110/C IE2	500	805	925	550	580	1130	210	285	240	22		425	1200	215	100	800	296	504	M16	300	800	1130	1200	1,08	693

DCM-GE 150 4 POLES - ELECTRONIC IN-LINE PUMPS FOR HEATING, AIR CONDITIONING, REFRIGERATION, SOLAR, AND SANITARY SYSTEMS - TWIN, FLANGED, WITH MCE/C INVERTER

Pumped liquid temperature range: from -10 °C to +140°C - Maximum ambient temperature: +40°C

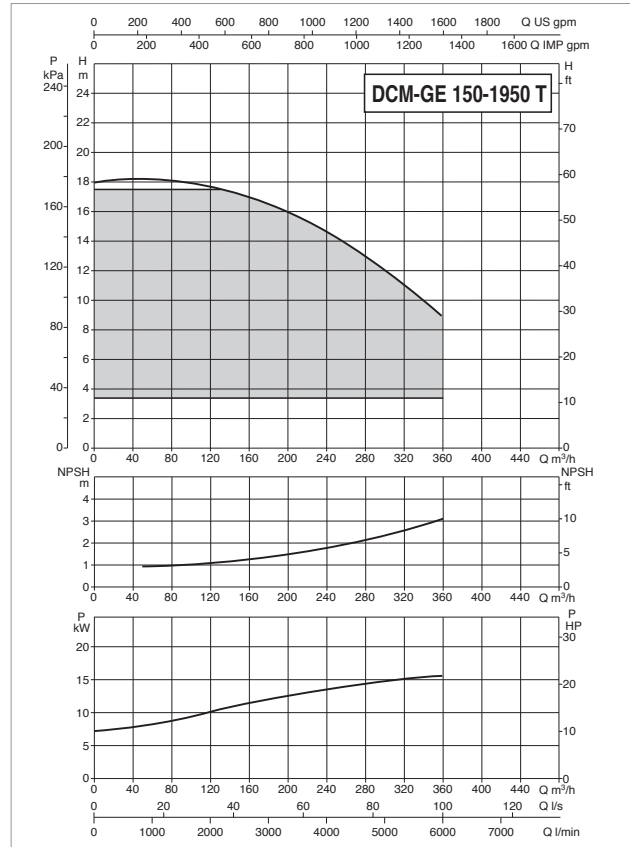
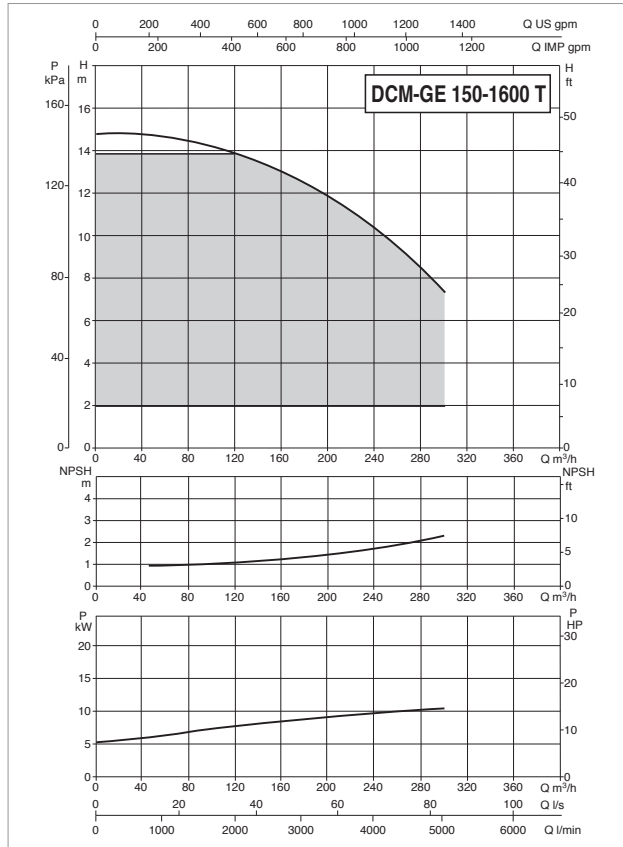

For the MEI index refer to the hydraulic data of the individual pump.

The performance curves are based on kinematic viscosity values = 1 mm²/s and density equal to 1000 kg/m³. Curve tolerance according to ISO 9906.

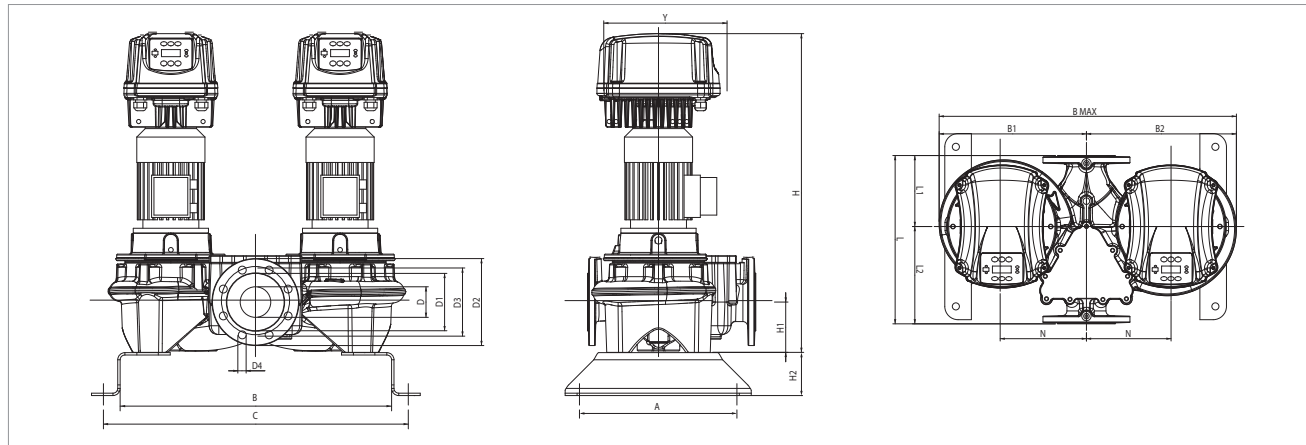

MODEL	ELECTRICAL DATA						
	POWER INPUT 50-60 Hz	MOTOR TYPE	n r.p.m.	P1 MAX W	P2 NOMINAL		In A
					kW	HP	
DCM-GE 150-1600/A/BAQE/ 11 T MCE110/C IE2 *	3x400 V ~	4 poles	1450	14,97	11	15	31,4
DCM-GE 150-1950/A/BAQE/ 15 T MCE150/C IE2 *		4 poles	1470	19,31	15	20	39,9

* ΔP-v proportional differential pressure adjustment mode also available.

MODEL	A	B	C	B1	B2	B max	D1	D2	D3	D4	no. of holes	Y	H	H1	H2	L	L1	L2	M	N	PACKING DIMENSIONS			VOL. (m ³)	WEIGHT kg
																					L/A	L/B	H		
DCM-GE 150-1600/A/BAQE/ 11 T MCE110/C IE2	500	805	925	550	580	1130	210	285	240	22	8	425	1305	215	100	800	296	504	M16	300	800	1130	1305	1,18	719
DCM-GE 150-1950/A/BAQE/ 15 T MCE150/C IE2	500	805	925	550	580	1130	210	285	240	22		425	1360	215	100	800	296	504	M16	300	800	1130	1360	1,23	818