

Product Data Sheet (2021-03-22)

FlexTherm Duo HLS 300 - 500

An indirectly heated and high yield water heater that is specially developed for combination with heat pumps. Including a permanently welded-in, extra large and double heat exchanger.



Type	Capacity [l]	Dimensions *			Heating surface area [m ²]	Heating capacity [kW] **	Water capacity [l/h] **	Insulation colour	Weight [kg]	###	Order Code
		Ø [mm]	H [mm]	Tilting height [mm]							
FlexTherm Duo HLS 300	300	660	1710	1750	3.2	64.3	1117	white	160	1	18171
FlexTherm Duo HLS 400	400	750	1630	1715	4.1	80.6	1401	white	198	1	18176
FlexTherm Duo HLS 500	500	750	1830	1895	4.8	95.7	1663	white	222	1	18181

* Dimensions including insulation.

** At 80 °C supply temperature and 60 °C potable water temperature.



Type	Distance from floor to connection centres				
	A [mm]	B [mm]	C [mm]	D [mm]	E [mm]
FlexTherm Duo HLS 300	65	305	845	945	1560
FlexTherm Duo HLS 400	70	330	870	970	1470
FlexTherm Duo HLS 500	70	330	990	1090	1670

Advantages

- High-quality glass lining according to DIN 4753/part 3 for potable hot water production and optimum corrosion protection by means of a standard Mg-anode.
- Equipped with a built-in thermometer and immersion pipe.
- Equipped with a DN 110 inspection flange at the side, suitable for connecting additional heating elements; Ex Works - closed with a removeable blind flange.
- The heating coil is designed to ensure full depth heating to prevent the accretion of Legionella bacteria.
- A set of adjustable feet is optionally available (Art.No. 18989).
- Circulation connection R ¾".

Technical information

- Maximum working pressure: 10 bar (potable water vessel) / 16 bar (heating coil).
- Maximum working temperature: 95 °C (potable water vessel) / 110 °C (heating coil).
- Insulation:

Standard colours: white (RAL 9010).

Including hard foam insulation (direct foam injection) with a polystyrene outer shell.

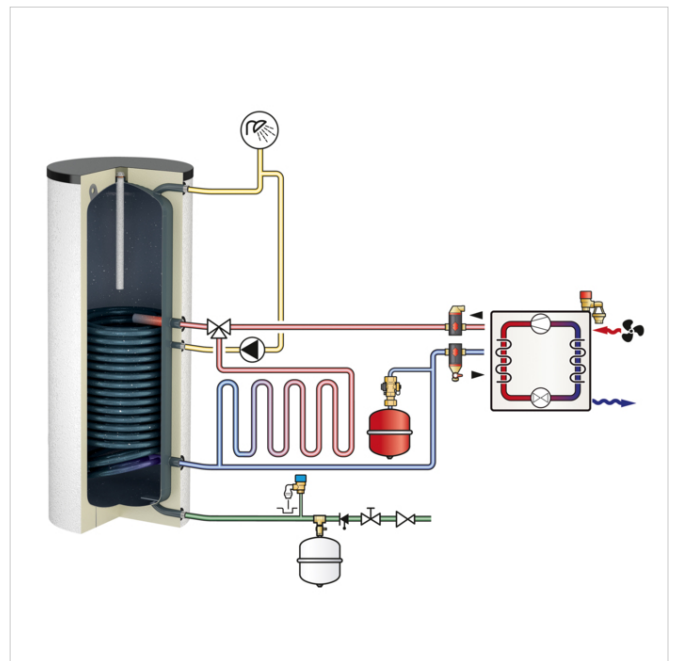
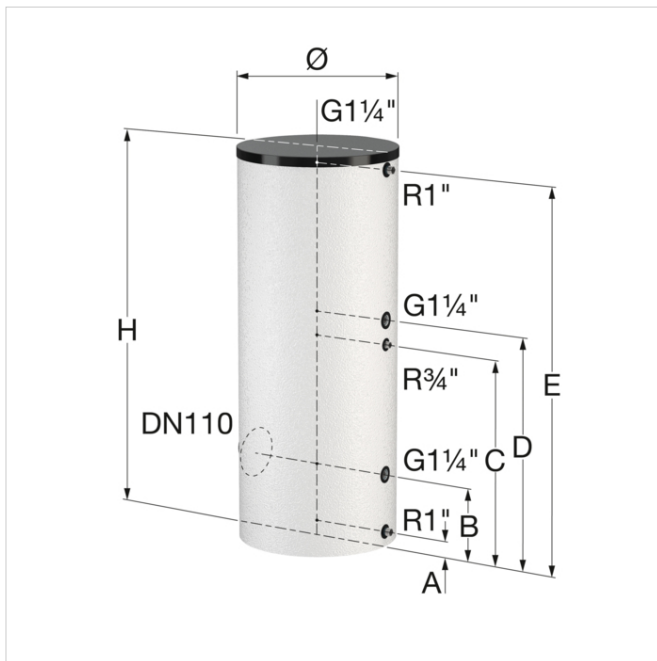

Find more information online:

[Manuals](#)

[Certificates](#)

[CAD drawings](#)

[Extra documentation](#)

Flamco Group
Plotterweg 31
3821 BB, Amersfoort - nl
T +31 33 299 75 00
E info@flamcogroup.com
I flamcogroup.com