

Product Data Sheet (2021-03-22)

FlexTherm Duo 750 - 1000

An indirectly heated and upright water heater including a permanently welded-in heating coil, suitable for all modern heating systems.



Type	Capacity [l]	Dimensions *			Heating surface area [m ²]	Heating capacity [kW] **	Water capacity [l/h] **	Insulation colour	Weight [kg]	###	Order Code
		Ø [mm]	H [mm]	Tilting height [mm]							
FlexTherm Duo 750	750	750	1970	2070	2.7	67.1	1166	white	280	1	19297
FlexTherm Duo 750	750	750	1970	2070	2.7	67.1	1166	white alu.	280	1	19298
FlexTherm Duo 1000	1000	800	2230	2320	3.2	73.9	1283	white	360	1	19305
FlexTherm Duo 1000	1000	800	2230	2320	3.2	73.9	1283	white alu.	360	1	19306

* Dimensions excluding insulation.

** At 80 °C supply temperature and 60 °C potable water temperature.



Type	Distance from floor to connection centres				
	A [mm]	B [mm]	C [mm]	D [mm]	E [mm]
FlexTherm Duo 750	60	320	890	1040	1880
FlexTherm Duo 1000	70	330	960	1110	2140

Advantages

- Minimum lime deposits due to smooth surfaces. High-quality glass lining according to DIN 4753/part 3 for potable hot water production and optimum corrosion protection by means of a standard Mg-anode.
- Equipped with a built-in thermometer.
- Including a clamping strip with which a temperature sensor can be affixed at any chosen height to enable optimum heat efficiency of the water heater.
- Feet adjustable in height for accurate levelling.
- Inspection flange at the side: DN 205, suitable for connecting additional heating elements; Ex Works - closed with a removeable blind flange.

- Suitable for connecting additional heating elements and fitted with a coupling sleeve for accessories.
- The heating coil is designed to ensure full depth heating to prevent the accretion of Legionella bacteria.

Technical information

- Maximum working pressure: 10 bar (potable water vessel) / 16 bar (heating coil).
- Maximum working temperature: 95 °C (potable water vessel) / 110 °C (heating coil).
- Insulation:

Standard colours: white (RAL 9010) and white aluminium (RAL 9006).

Including EPS insulating mantle (fire category B1) with a polypropylene outer shell (fire category B2).

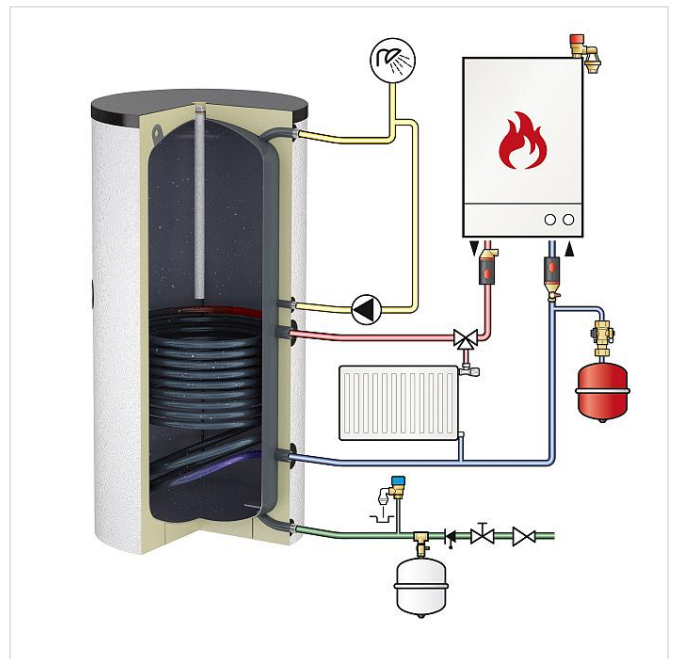
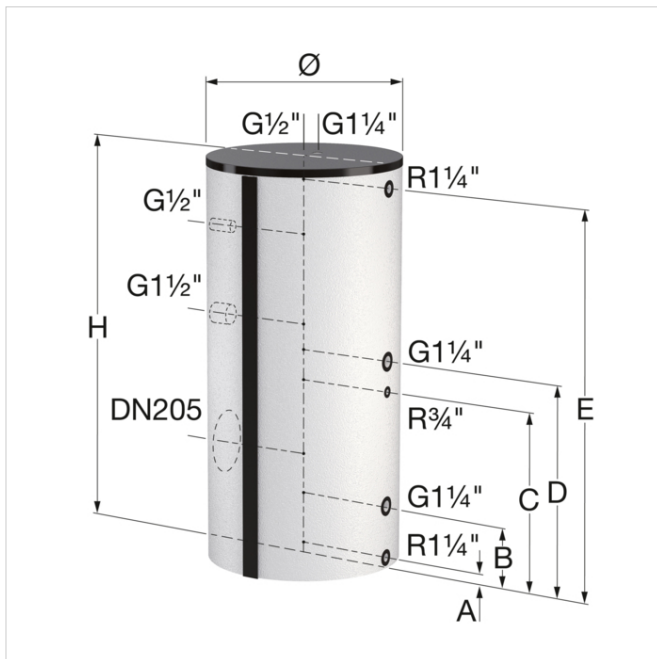

Find more information online:

[Manuals](#)

[Certificates](#)

[CAD drawings](#)

[Extra documentation](#)

Flamco Group
 Plotterweg 31
 3821 BB, Amersfoort - nl
 T +31 33 299 75 00
 E info@flamcogroup.com
 I flamcogroup.com