

0(2)...10 V electric linear actuator

PRODUCT DATA



SPECIFICATIONS

Order number M41A15
Supply voltage 24VAC; 50/60Hz
Power consumption 4VA
Signal input 0/2...10V factory setting:
0 (2)V; actuator stem retracts
10 V; actuator stem extends

Nominal stroke 6.5 mm
Run time 15 s
Nominal stem force $\geq 400\text{N}$

Temperature limits;
ambient operating limits 0... +50°C 5 - 95%rh
Ambient storage limits -40... +70°C 5 - 95%rh
Medium valve temperature max +130°C

Signals
Input voltage range Y = 0...10 VDC or 2...10 VDC
Input resistor $R_i = 100\text{k}\Omega$
Signal source output register max 1k Ω

Safety
Protection standard IP54 in acc. with EN60529
Protection class II in acc. with EN60730-1
Flame retardant V0 in acc. with UL94 (optional with metal cable gland)

Material
Cover ABS -FR
Base glass fibre reinforced plastic
Wiring
Terminals 1.5 mm²
Cable entry M20*1,5
Dimensions See next page
Weight 0,37 kg

GENERAL

- For domestic hot water applications
- For integration into compact or conventional stations for direct or indirect district heating connections
- For air handling units

FEATURES

- Easy to install
- Short run time
- Low power consumption
- Microprocessor controlled for exact positioning
- Direction of movement is reversible
- Integrated mechanism limits the stem force
- Equipped with manual operator

WITH THE VALVES

- VD215-VD232
- V5872B/D
- V5832B 2083-2117
- V5833A 2084-2118



GENERAL

The drive of a synchronous motor is converted into linear motion of the actuator stem by using a spur gear transmission. Actuator and valve are directly connected by a nut. An integrated mechanism limits the stem force. Installed microswitches switch off the actuator precisely when the specified stem force is reached.

DIMENSIONS (mm)

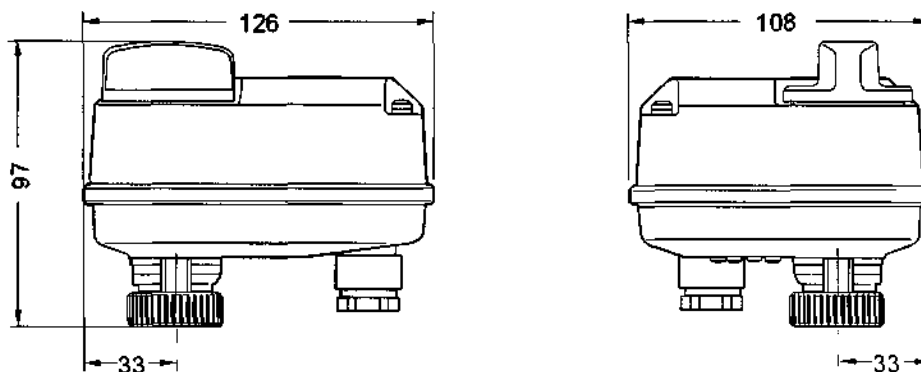

MANUAL OPERATION

The actuators are equipped with a manual operator. Manual operation is only possible after the power supply is switched off or disconnected. It has to be used only to check the valve operation. To operate turn the manual operator knob clockwise to move the stem downward and counter-clockwise to move the stem upward.

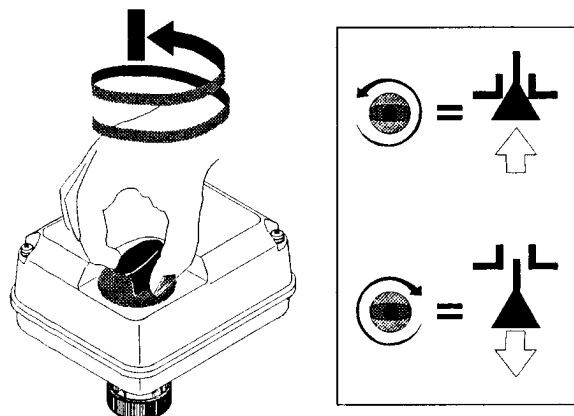

INSTALLATION AND WIRING

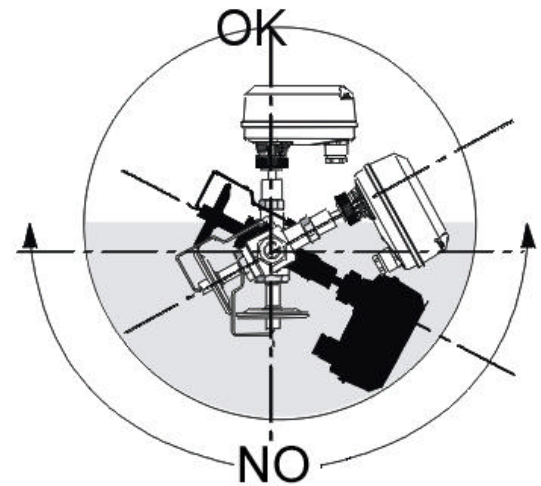
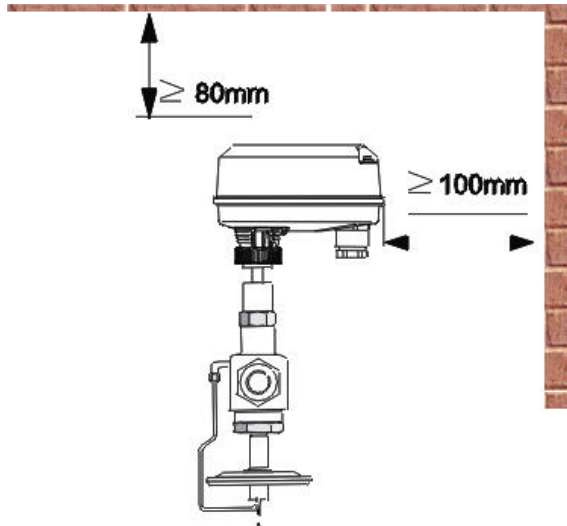

WIRING

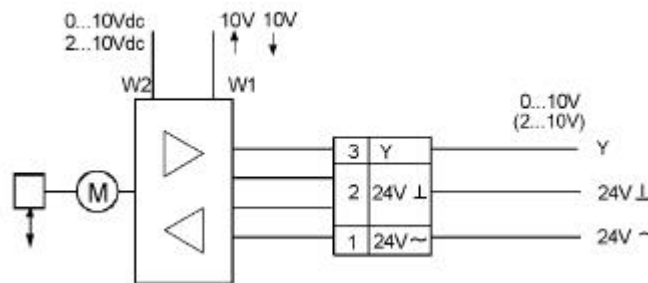

Y-SIGNAL OVERRIDE

To override the Y-signal and force the actuator in 0% or 100% stroke position, inputs 1 and 2 has to be connected as follows:

- 0% stroke position (stem fully retracted):
24V \perp applied to input Y
- 100% stroke position (stem fully extended):
24V \sim applied to input Y

or vice versa if reverse action is selected

Y-SIGNAL BREAK

In case of wire break at Y-signal input, the actuator is moved into the 0V signal position (safety position).

DIRECTION OF ACTION; INPUT SIGNAL RANGE

The direction of action (direct or reverse) can be selected by changing the position of jumper plug W1. It is set by the factory such that the stem extends at increasing signal and retracts at decreasing signal (direct action).

The range of the analog input signal Y (0 to 10 Vdc or 2 to 10 Vdc) can be selected by changing the position of jumper plug W2. The factory set is at 0 to 10 Vdc.

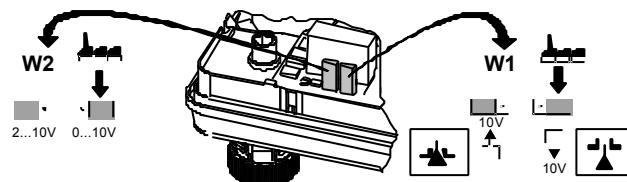

20200110

OUMAN OY

<https://ouman.fi>