

MODULEX EXT

348 - 440 - 550 - 660 - 770 - 900

INSTALLATION AND MAINTENANCE INSTRUCTIONS



<https://www.unicalag.it/prodotti/professionale-300/commercial-condensazione-alluminio/347/modulex-ext>

Provisions for proper disposal of the product

After decommissioning, this appliance must not be disposed of as mixed urban waste.

Separate waste collection is mandatory for this type of waste, in order to allow the recovery and reuse of the materials making up the appliance.

Please contact operators authorised for the disposal of this type of appliances

Incorrect management of waste and of its disposal has potential negative effects on the environment and human health

The  symbol on the appliance, represents the prohibition to dispose of the product as mixed urban waste.

Attention: this manual contains instructions for the exclusive use of the professionally qualified installer and/or maintenance technician in compliance with current legislation.

The user is NOT qualified to intervene on the boiler.

The manufacturer will not be held liable in case of damage to persons, animals or objects resulting from failure to comply with the instructions contained in the manuals supplied with the boiler

1 GENERAL INFORMATION	4
1.1 General warnings.....	4
1.2 Symbols used in the manual.....	5
1.3 Appropriate use of appliance.....	5
1.4 Information for system manager.....	5
1.5 Safety warnings.....	6
1.6 Technical data plate.....	7
1.7 Water treatment.....	8
1.8 Boiler antifreeze protection.....	9

2 TECHNICAL SPECIFICATIONS{J}AND DIMENSIONS	10
2.1 Technical features.....	10
2.2 Main components view and dimensions.....	10
2.3 Dimensions.....	12
2.4 Operating data.....	13
2.4.1 Technical data according to ErP Directive.....	14
2.4.2 Determination of the primary circuit pump or boiler pump.....	15

3 INSTRUCTIONS FOR THE INSTALLER	16
3.1 General warnings.....	16
3.2 Installation rules.....	16
3.3 Preventive system verification and adjustment operations.....	16
3.4 Package and Weights.....	17
3.4.1 Unloading operations.....	18
3.5 Positioning in boiler room.....	19
3.6 Flue gas exhaust pipe connection.....	20
3.7 Boiler connection.....	21
3.8 Connection.....	22
3.9 Filling and emptying the system.....	24
3.10 Electrical connections.....	26
3.11 Commissioning.....	35
3.12 Measurement of combustion efficiency during installation.....	37
3.12.1 Activation of the calibration function.....	37
3.12.2 Positioning the sensors.....	37
3.13 Checking burner pressure adjustment.....	38
3.14 Control panel, emergency operation and safety devices.....	39
3.15 Programming operating parameters.....	40
3.16 Release and reset error codes.....	43

4 INSPECTION AND MAINTENANCE	43
4.1 Inspection and maintenance instructions.....	43
4.2 Wiring diagram.....	50

1.1 - GENERAL WARNINGS

The instruction manual is an integral and essential part of the product and must be kept by the user.

Read the warnings contained in this instruction manual carefully as they provide important guidelines regarding installation, use and maintenance safety.

Keep the manual with care for further consultation.

Your appliance must be installed and serviced in compliance with the standards in force according to the manufacturer instructions, up to standard and by legally qualified and certified personnel. Systems for the production of domestic hot water **MUST** be constructed entirely with compliant materials.

By professionally qualified personnel we mean: personnel with specific technical skill in the field of heating system components for civil use, domestic hot water production and maintenance. Personnel must have the qualifications provided for by current legislation.

Incorrect installation or improper maintenance can cause damage to persons, animals or objects for which the manufacturer is not responsible.

Before performing any cleaning or maintenance, disconnect the appliance from the energy mains by acting on the switch of the system and/or through the specific cut-off devices.

Do not obstruct the terminals of the intake/exhaust ducts.

In the event of failure and/or malfunctioning of the appliance, switch it off and do not try to repair it or intervene on it directly. Contact only personnel qualified in compliance with law.

Any product repairs must be performed solely by personnel authorised by Unical, using original spare parts only. Failure to comply with the above can compromise the safety of the appliance and void the warranty.

To guarantee appliance efficiency and its correct operation, yearly maintenance must be performed by qualified personnel.

Should you decide not to use the appliance, parts entailing potential sources of hazard must be made safe.

Before commissioning an appliance that has not been used, wash the domestic hot water production system, making the water flow until it has been fully replaced.

Should the appliance be sold or transferred to a new owner or if you move and leave the appliance, always make sure that the instruction manual accompanies it so that the new owner and/or installer can refer to it.

Only original accessories must be used for all appliances with optional features or kits (including electric ones).

This appliance is intended solely for the use for which it was expressly designed.

Any other use is to be considered improper and therefore dangerous (*)
(see 1.7 Water Treatment).

**ATTENTION**

THE THERMAL UNIT MUST BE INSTALLED IN SUCH A WAY AS TO AVOID, IN THE ENVISAGED OPERATING CONDITIONS, THE LIQUID IT CONTAINS FROM FREEZING AND PREVENT COMMAND AND CONTROL PARTS FROM BEING EXPOSED TO TEMPERATURES BELOW -15°C AND ABOVE +40°C.

THE THERMAL UNIT MUST BE PROTECTED FROM CLIMATIC/ENVIRONMENTAL VARIATIONS WITH:

- The insulation of hydraulic pipes and condensation drain
- The use of specific antifreeze products in the hydraulic system.

1.2 - SYMBOLS USED IN THE MANUAL

When reading this manual, pay special attention to the parts marked by the symbols shown:



DANGER!
Serious danger
to safety
and health



ATTENTION!
Possible dangerous
situation for the product
and the environment



NOTE!
Tips
for the user



NOTE!
For further details
refer to the Technical Informa-
tion:
at the address indicated
on page 2.



DANGER!
Danger of burns!



OBLIGATION!
wear protective
gloves

1.3 - APPROPRIATE USE OF APPLIANCE



The boiler has been constructed according to the current level of engineering and acknowledged technical safety rules.

Nonetheless, improper use could result in hazards for the safety and life of the user or other persons, i.e. damage to the appliance or other property.

The appliance is designed to work in heating systems, with hot water circulation, for the production of domestic hot water.

Any other use shall be considered as misuse.

UNICAL will not be held liable for any damage resulting from improper use.

Use according to the intended purposes also includes strict compliance with the instructions in this manual.

1.4 - INFORMATION FOR THE SYSTEM MANAGER



The user must be instructed on use and operation of the heating system, in particular:

- Deliver these instructions to the user, as well as other documents concerning the appliance inserted in the envelope inside the packaging. **The user must keep this documentation safe for future reference.**
- Inform the user about the importance of the air vents and the flue gas exhaust system, highlighting their essential features and the absolute prohibition of modifying them.
- Inform the user on how to control the system's water pressure as well as operations to restore it.
- Inform the user on correct temperature control, control units/thermostats and radiators for saving energy.
- Please note that, in compliance with the standards in force, the inspection and maintenance of the appliance must be carried out in compliance with the regulations and frequency indicated by the manufacturer.
- Should the appliance be sold or transferred to a new owner or if you move and leave the appliance, always make sure that the instruction manual accompanies it so that the new owner and/or installer can refer to it.

The manufacturer will not be held liable in the event of damage to persons, animals or objects resulting from failure to comply with the instructions contained in this manual.

1.5 - SAFETY WARNINGS



ATTENTION!

The appliance must not be used by children.

The appliance may be used by adults and only after carefully reading the operating instructions manual for the user / person in charge.

Children must be supervised so they do not play or tamper with the appliance.



ATTENTION! The appliance must be installed, adjusted and maintained by professionally qualified personnel, in compliance with the standards and provisions in force. Incorrect installation can cause damage to persons, animals and property for which the manufacturer cannot be held liable.



DANGER! NEVER attempt performing maintenance or repairs on the boiler on your own initiative.

Any work must be done by professionally qualified personnel. We recommend stipulating a maintenance contract.

Insufficient or irregular maintenance can jeopardise the operating safety of the appliance and cause damage to persons, animals and property for which the manufacturer will not be held liable.



ATTENTION! Modifying parts connected to the appliance (upon completing appliance installation)

Do not modify the following parts:

- the boiler
- the gas, air, water and electricity supply lines
- the flue gas pipe, the safety valve and the exhaust pipe
- the construction parts which affect the operating safety of the appliance



ATTENTION!

To tighten or loosen the screwed fittings, use only appropriate fixed spanners.

Incompliant use and/or inappropriate tools can cause damage (e.g. water or gas leakage).



ATTENTION!

Indications for propane gas-fired appliances

Make sure that the gas tank has been deaerated before installing the appliance.

For state-of-the-art tank venting, contact the LPG supplier or person qualified in compliance with the legal requirement.

If the tank has not been professionally deaerated, ignition problems could arise. In that case, contact the supplier of the LPG tank.



DANGER Gas smell Should a smell of gas be perceived, follow these safety guidelines:

- do not turn electrical switches on or off
- do not smoke
- do not use the telephone
- close the gas shut-off valve
- ventilate the area where the gas leakage has occurred
- inform the gas supplier or a company specialised in the installation and maintenance of heating systems.



DANGER! Explosive and easily flammable substances

Do not use or store explosive or easily flammable materials (e.g. petrol, paints, paper) in the room where the appliance is installed.



DANGER! Do not use the appliance to support any object. Specifically, do not place any liquid containers (Bottles, Glasses, Containers or Detergents) on top of the boiler. If the appliance is installed inside a box, do not insert or place other objects inside it.

1.6 - TECHNICAL DATA PLATE

The CE Marking

certifies the appliance compliance with the essential safety requirements defined in the applicable European Directives and Regulations and that its operation meets the technical standards of reference.

The CE marking is affixed on each individual appliance by a special label.

The EC declaration of conformity, issued by the Manufacturer pursuant to international regulations, can be found in the documentation accompanying the product.



The technical data plate can be found under the casing, on the front fixing crosspiece. ITS DUPLICATE is placed next to the temperature control unit.

KEY:

- 1 = CE monitoring body
- 2 = Type of boiler
- 3 = Boiler model
- 5 = (S.N°) Serial Number
- 6 = P.I.N. Product Identification Number
- 7 = Types of approved flue gas exhaust configurations
- 8 = (NOx) NOx Class

- A = Heating circuit characteristics
- 9 = (Pn) Effective nominal output
- 10 = (Pcond) Effective output in condensation
- 11 = (Qn) Maximum thermal flow rate
- 12 = (Adjusted Qn) Adjusted for rated heat output
- 13 = (PMS) Max. heating operating pressure
- 14 = (T max) Max. heating temperature

- B = Domestic hot water circuit characteristics
- 15 = (Qnw) Rated heat output in domestic hot water function (if different than Qn)
- 16 = (D) Specific D.H.W. flow rate according to EN625-EN13203-1
- 19 = (PMW) Max. domestic hot water operating pressure
- 20 = (T max) Max. domestic hot water temperature

- C = Electrical characteristics
- 21 = Electrical power supply
- 22 = Consumption
- 23 = Protection rating

- D = Countries of destination
- 24 = Direct and indirect countries of destination
- 25 = Gas category
- 26 = Supply pressure

- E = Factory settings
- 27 = Adjusted for gas type X
- 28 = Space for national brands

- G = ErP
- 29 = Seasonal energy efficiency to heat the room
- 30 = Seasonal water heating energy efficiency.

(2)		
Model	(3)	
S.N°	(5) / _____ PIN (6)	
Types	(7) NOx (8)	
A Central Heating	Pn (9) kW Pcond (10) kW	
	Qn (11) kW Adjusted Qn (12) kW	
	PMS (13) bar T max (14) °C	
	(15) kW D (16) l/min	
	PMW (19) bar T max (20) °C	
s (29) % wh (30) %		
E Factory setting <input checked="" type="checkbox"/> MET <input type="checkbox"/> GPL		
D Countries of destination		
(27) mbar <input type="checkbox"/> mbar <input type="checkbox"/> mbar <input type="checkbox"/> mbar <input type="checkbox"/> mbar <input type="checkbox"/> mbar <input type="checkbox"/> mbar <input type="checkbox"/> mbar <input type="checkbox"/>		
C Electrical Power supply		
(21) V Hz (22) W		
IP class: (23)		
 (28) (1)		
Made in Italy		

1.7 - WATER TREATMENT



Feed water treatment prevents problems and maintains the functionality and efficiency of the generator over time.



ATTENTION!
ANY DAMAGE TO THE BOILER CAUSED BY THE FORMATION OF SCALING OR BY CORROSIVE WATER WILL NOT BE COVERED BY THE WARRANTY.



The ideal water pH in heating systems must be within:

VALUE	MIN	MAX
PH	6.5	8
Hardness [°fr]	9	15



ATTENTION (*) see general warnings 1.1:
The heating only models are NOT suitable for the production of water for human consumption according to Ministerial Decree D.M. 174/2004.



To minimise corrosion, it is crucial to use a corrosion inhibitor; in order for it to work properly, the metal surfaces must be clean.
(see system protection ACCESSORIES sect. in domestic price list)

NOTE!

Further details in the section
“Technical Information” on the boiler
page of the www.unicalag.it website

1.8 - BOILER ANTIFREEZE PROTECTION

It is activated by default



This protection can trigger only if the electricity and gas supplies are connected.

If one of the two is not available and upon reset 11 (SM) a temperature level between 2 and 5°C is detected, the appliance will behave as described in the table below, pos 2.



The heating system can be protected effectively from frost by using antifreeze products with inhibitor for heating systems (specific for multi-metal)

Do not use car engine antifreeze products as they could damage the water gaskets.

P O S	ANTIFREEZE FUNCTION				
	Supplies		11 - SR (*)	Status antifreeze function	Actions
	Electric	Gas			
1	ON	ON	< 7 °C	ON	- Burner and Pump ON until T > 15°C
2	ON	OFF	< 5 ÷ 5 °C	OFF	FAULT SIGNAL CODE 16 (see par. 4.4 ERROR CODES). Ignition inhibited.
	OFF	ON		OFF	Ignition inhibited.
	OFF	OFF		OFF	Ignition inhibited.

(*) SR Sensor par. 2.2

2

TECHNICAL FEATURES AND DIMENSIONS

2.1 - TECHNICAL FEATURES



NOTE!
Further details in the section
"Technical Information" on the boiler
page of the www.unicalag.it website

2.2 - INTERNAL VIEW WITH THE INDICATION OF THE MAIN COMPONENTS

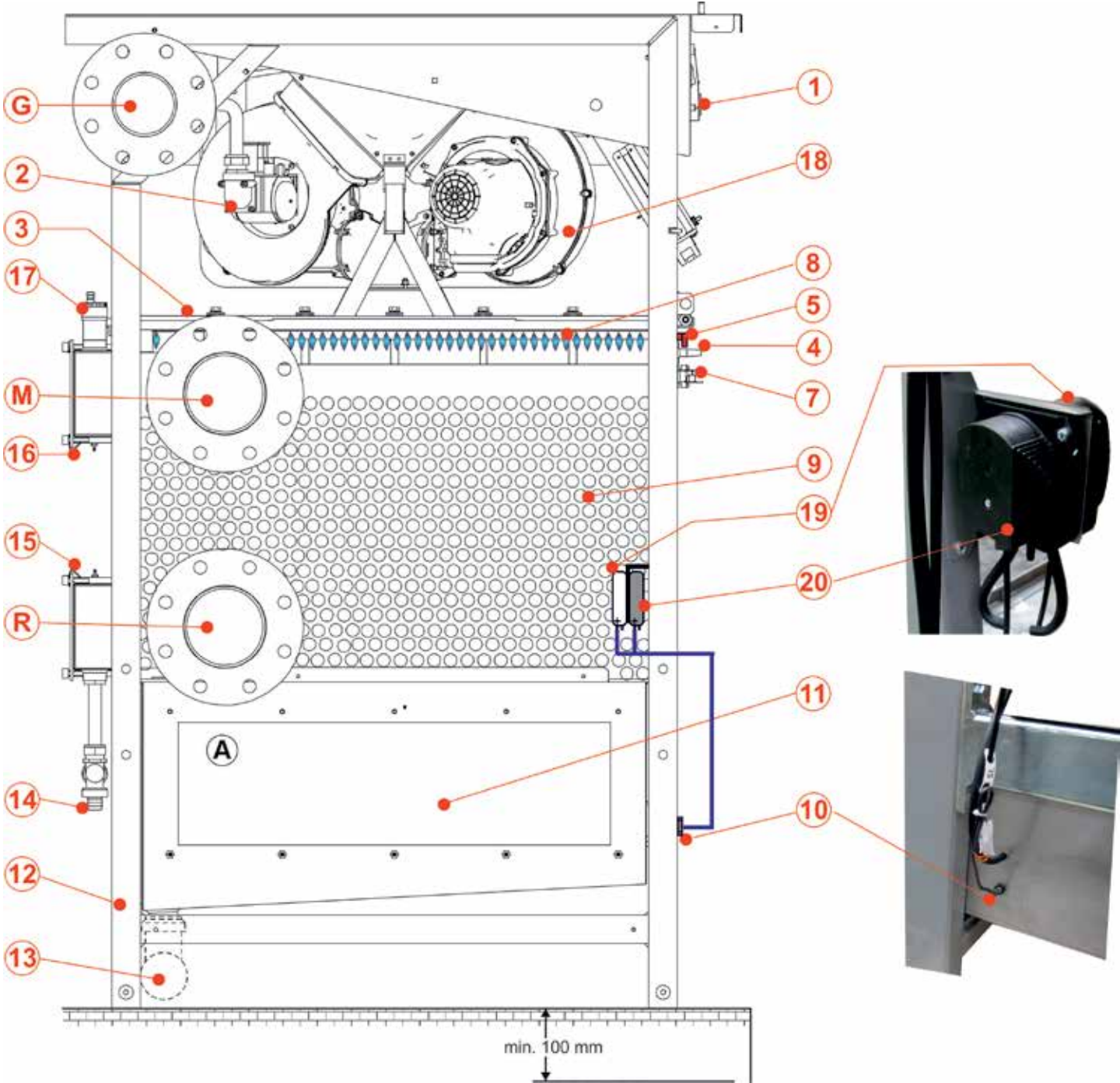

KEY			
No.	C.E.	S.E.	Description
1		Ufly	Control panel
2		VG	Gas valve
3			Burner cover
4		E. ACC.	Ignition electrode
5		E. RIL.	Detection electrode
7		TL	Limit Thermostat
8			Burner
9			Silicon Aluminium Heat Exchanger
10		SL	Condensate level sensor
11			Condensate collection pan / Chimney fitting
12			Frame

13			Condensation drainage outlet
14			Drain valve
15		SRR	Global Return Sensor
16		SMG	Global Flow Sensor
17			Automatic air vent
18			Fan
19		PF min	Smoke pressure minimum pressure switch
20		PF	Smoke pressure switch



Flue gas outlet LEFT, RIGHT, REAR side
Flow LEFT side
Return LEFT side
Gas inlet LEFT side

BCM: under the front casing

2.3 - DIMENSIONS

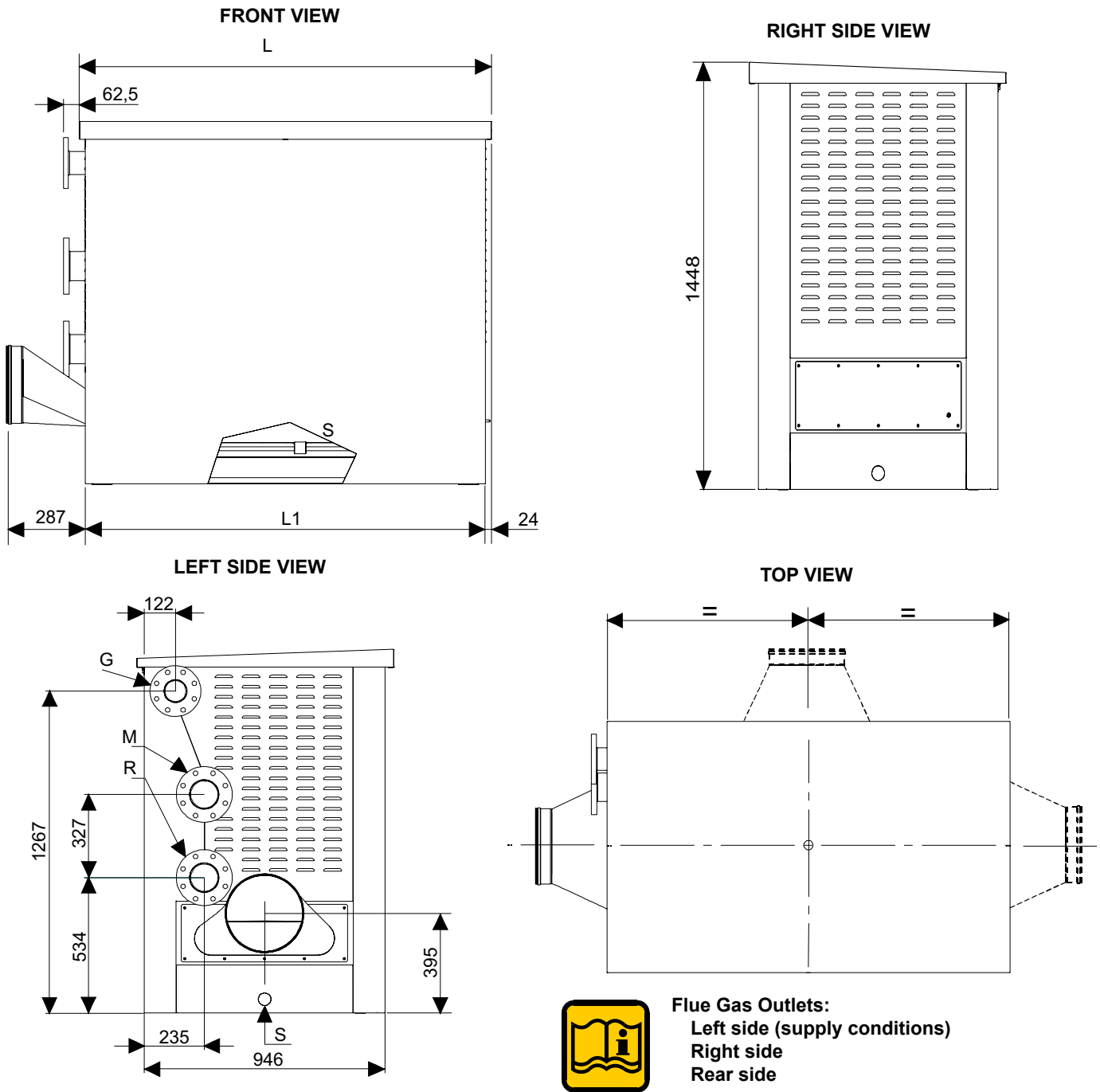



MODULEX EXT		348	440	550	600	770	900
Dimensions							
No. of heating elements		4	4	5	6	7	8
Height	mm	1448	1448	1448	1448	1448	1448
Width "L"	mm	1087	1087	1355	1355	1623	1623
Width "L1"	mm	1039	1039	1307	1307	1575	1575
Depth	mm	946	946	946	946	946	946
Connection dimensions							
Gas Fitting G	mm (inch)	80 (3)	80 (3)	80 (3)	80 (3)	80 (3)	80 (3)
System flow M	mm (inch)	100 (4)	100 (4)	100 (4)	100 (4)	100 (4)	100 (4)
System return R	mm (inch)	100 (4)	100 (4)	100 (4)	100 (4)	100 (4)	100 (4)
Chimney fitting	mm	250	250	250	300	300	300
Condensation drain	mm	40	40	40	40	40	40

2.4 - OPERATING DATA AND GENERAL FEATURES

For the adjustment data: NOZZLES - PRESSURE - COLLECTORS - FLOW RATES refer to the paragraph ADAPTATION TO OTHER TYPES OF GAS.

MODULEX		EXT 348	EXT 440	EXT 550	EXT 660	EXT 770	EXT 900
Boiler category		II _{2H3P}	II _{2H3P}	II _{2H3P}	II _{2H3P}	II _{2H3P}	
Modulation ratio		1:15.8	1:19.6	1:24.5	1:29.4	1:34.3	1:39.2
Rated heat output on P.C.I. Qn	kW	348	432	540	648	756	864
Minimum heat output on P.C.I. Qmin	kW	22					
Effective nominal output (Tr 60 / Tm 80 °C) Pn	kW	341.7	424.3	530.4	636.5	742.6	849.0
Minimum effective output (Tr 60 / Tm 80 °C) Pn min	kW	20.6					
Effective nominal output (Tr 30 / Tm 50 °C) Pcond	kW	359.2	445.0	557.8	670.1	783.2	900.3
Minimum effective output (Tr 30 / Tm 50 °C) Pcond min	kW	23.9					
Nominal output performance (Tr 60 / Tm 80°C)	%	98.2					
Minimum output performance (Tr 60 / Tm 80°C)	%	93.5					
Nominal output performance (Tr 30 / Tm 50°C)	%	104					
Minimum output performance (Tr 30 / Tm 50°C)	%	109					
Performance at 30% of the load (Tr 30°C)		106.8	107.3	107.5	108.3	107.8	107.6
Combustion efficiency at nominal load	%	97.8					
Combustion efficiency with reduced load	%	98.5					
Casing heat loss with burner on (Qmin)	%	5.04					
Casing heat loss with burner on (Qn)	%	0.1					
Net flue gas temperature tf-ta (min)(*)	°C	31					
Net flue gas temperature tf-ta (max)(*)	°C	46.0	46.7	46.7	46.7	46.7	45.8
Maximum permitted temperature	°C	100					
Maximum operating temperature	°C	85					
Flue gas mass flow rate (min)	kg/h	25					
Flue gas mass flow rate (max)	kg/h	558	693	866	1040	1213	1386
Excess air	%	24.25					
Heat loss at chimney with burner on (min)	%	1.5					
Heat loss at chimney with burner on (max)	%	2.40	2.58	2.53	2.51	2.58	2.58
Minimum heating circuit pressure	bar	0.5					
Maximum heating circuit pressure	bar	6					
Water content	L	67	67	80	94	108	122
Methane gas consumption G20 (sup.p. 20 mbar) at Qn	m³/h	36.80	45.68	57.10	68.52	79.94	91.36
Methane gas consumption G20 (sup.p. 20 mbar) at Qmin	m³/h	2.33					
Gas consumption G25 (sup.p. 20/25 mbar) at Qn	m³/h	42.80	53.13	66.41	79.69	92.97	106.25
Gas consumption G25 (sup.p. 20/25 mbar) at Qmin	m³/h	2.71					
Propane gas consumption (sup.p. 37/50 mbar) at Qn	kg/h	27.01	33.53	41.92	50.30	58.68	67.01
Propane gas consumption (sup.p. 37/50 mbar) at Qmin	kg/h	1.71					
Chimney base maximum pressure available	Pa	100					
Max condensate production	kg/h	59.1	73.4	91.7	110	128.4	146.7
Emissions							
CO at maximum heat output with 0% of O2 (PCI)	mg/kWh	55	72	76	87	72	76
NOx at maximum heat output with 0% of O2 (PCI)	mg/kWh	56	52	52	58	55	57
(***) Sound pressure level	dB (A)	54	54	54	54	54	56
Electrical data							
Power supply voltage/frequency	V/Hz	230 / 50					
(**) Protection rating	IP	X5D					
Room Temperature = 20°C							
(*) Temperature detected with appliance operation flow 80°C / ret. 60°C							
CO ₂ (min/max) See "NOZZLES - PRESSURE" table							
Seasonal Energy Efficiency according to 2009/125 EEC (<=400Kw) η _s - see ErP table							
Leaks upon stop at ΔT 30°C - P _{stb} - see ErP table							
Electricity consumption on standby - P _{sb} - see ErP table							
(***) at 1 m away in free field.							
(**) The IP protection rating is obtained with the cover down							

2.4.1 - TECHNICAL DATA ACCORDING TO ErP DIRECTIVE

MODULEX			EXT 348	EXT 440	EXT 550	EXT 660	EXT770	EXT 900
Element	Symbol	Unit						
Effective nominal output	Prated	kW	342	424	530	636	743	849
Seasonal energy efficiency of central heating	η_s	%	93					
Season efficiency class for heating			A	*	*	*	*	*
For boilers for central heating and mixed boilers: effective heat output								
Effective heat output with high temperature capacity (Tr 60 °C / Tm 80 °C)	P ₄	kW	341.7	-	-	-	-	-
Rated heat output efficiency with high temperature capacity (Tr 60 °C / Tm 80 °C)	η_4	%	88.5	-	-	-	-	-
Effective output at 30% of the rated heat output with low temperature capacity (Tr 30 °C)	P ₁	kW	11.5	-	-	-	-	-
Performance at 30% of the rated heat output with low temperature capacity (Tr 30 °C)	η_1	%	96.2	-	-	-	-	-
Boiler with output range adjustment: YES / NO			NO	NO	NO	NO	NO	NO
Auxiliary electricity consumption								
With a full load	elmax	kW	0.393	0.626	0.783	0.940	1.096	1.252
With a partial load	elmin	kW	0.054					
Standby mode	P _{SB}	kW	0.020					
Other elements								
Heat dispersion on standby	P _{stb}	kW	0.2114	0.2114	0.2114	0.2114	0.2114	0.2114
Nitrogen oxides emissions ref. PCS	NO _x	Mg/kWh	49					
NO _x class			6					
Annual electricity consumption	Q _{HE}	GJ	1050	1303	1633	1959	2286	2612
For mixed heating appliances								
Declared load profile			-	-	-	-	-	-
Water heating energy efficiency	η_{wh}	%	-	-	-	-	-	-
Daily consumption of electricity	Q _{elec}	kWh	-	-	-	-	-	-
Daily consumption of fuel	Q _{fuel}	kWh	-	-	-	-	-	-
Internal sound power level	L _{wa}	dB (A)	-	-	-	-	-	-
Annual electricity consumption	AEC	kWh	-	-	-	-	-	-
Annual fuel consumption	AFC	GJ	-	-	-	-	-	-
Seasonal DHW efficiency class			-	-	-	-	-	-

2.4.2 - DETERMINATION OF THE PRIMARY CIRCUIT PUMP OR BOILER PUMP

The boiler pump must have head that is able to ensure the pump's flow rates according to the circuit's Δt .



The pumps must be determined by the installer or designer according to the boiler and system data.

The pump is not an integral part of the boiler. It is recommended to select a pump with a flow rate and head of approximately 2/3 of its characteristic curve.

MODULEX EXT 440	
Maximum flow rate in l/h ($\Delta t=15K$)	24,326
Requested rated flow rate in l/h ($\Delta t=20K$)	18,243

MODULEX EXT 770	
Maximum flow rate in l/h ($\Delta t=15K$)	42,570
Requested rated flow rate in l/h ($\Delta t=20K$)	31,926

MODULEX EXT 550	
Maximum flow rate in l/h ($\Delta t=15K$)	30,404
Requested rated flow rate in l/h ($\Delta t=20K$)	22,804

MODULEX EXT 900	
Maximum flow rate in l/h ($\Delta t=15K$)	48,647
Requested rated flow rate in l/h ($\Delta t=20K$)	36,487

MODULEX EXT 660	
Maximum flow rate in l/h ($\Delta t=15K$)	36,487
Requested rated flow rate in l/h ($\Delta t=20K$)	27,365

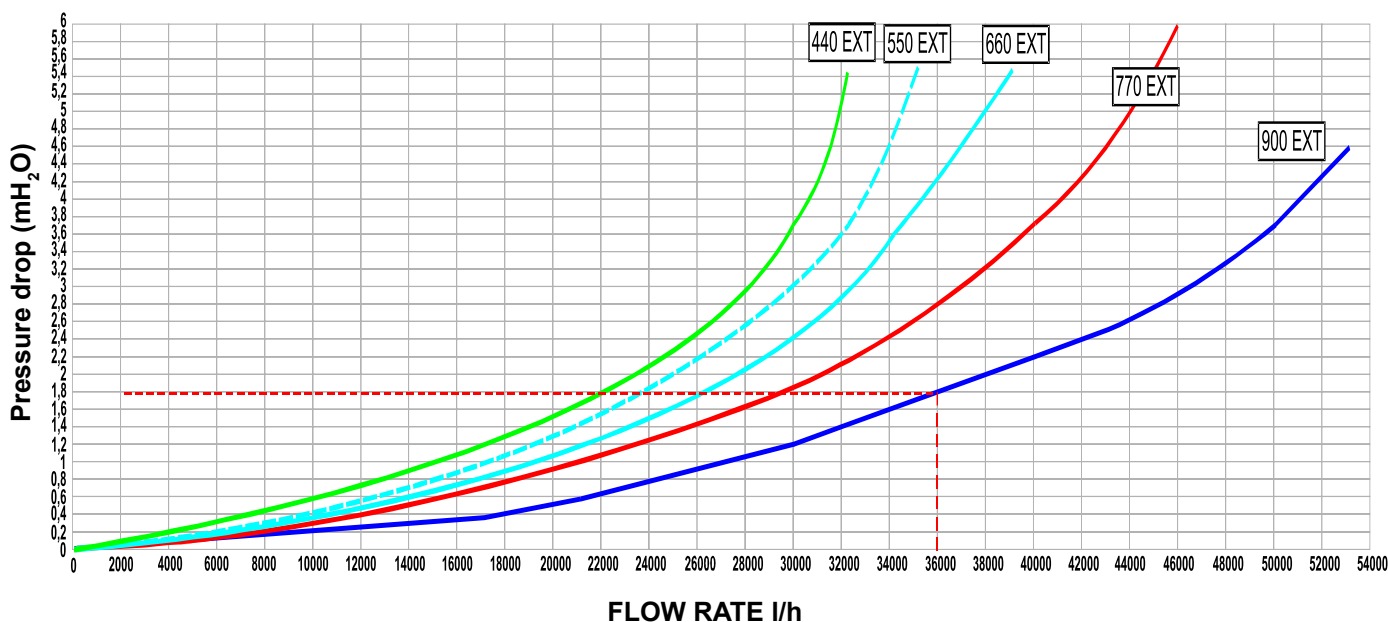

Technical Features



EXAMPLE:

For a ΔT 20K, of a MODULEX 900, the maximum water flow rate required is 36,289 l/h. The graph of the boiler pressure drops shows that the pump must ensure a head of at least 1.6 m/H₂O

NOTE:

It is always advisable to use a hydraulic separator (*) between the boiler circuit and the system.



(*) For the features, refer to the **SPINOX** installation manual, available on the website.

INSTRUCTIONS FOR INSTALLATION

3.1 - GENERAL WARNINGS



ATTENTION!

This boiler is intended solely for the use it was expressly designed for. Any other use is considered improper and therefore dangerous.

This boiler heats water at a temperature lower than the atmospheric pressure boiling temperature.



ATTENTION!

In rooms with the presence of aggressive vapours or dust, the appliance must operate independently from the air inside the installation room!



Before connecting the boiler, have professionally qualified personnel:

- a) **Thoroughly wash all of the system piping to remove any residues or impurities which could jeopardise proper operation of the boiler, even from a hygiene point of view.**
- b) Check that the boiler is set up to operate with the type of fuel available.
The type of fuel can be seen written on the package and on the technical feature plate.
- c) Check that the chimney/flue has an appropriate draught, without any bottlenecks, and that no exhausts from other appliances are inserted, unless the flue has been implemented to accommodate several utilities according to specific standards and requirements in force. Only after this check can the fitting be mounted between the boiler and chimney/flue.



ATTENTION!

The appliance must be installed by a qualified technician with the technical-professional requirements according to law 46/90 which, under his own responsibility, guarantees compliance with standards according to good practice rules.



ATTENTION!

Mount the appliance respecting the minimum distances required for installation and maintenance.



The boiler must be connected to a heating system compatible with its performance and output.

3.2 - STANDARDS FOR INSTALLATION

It must be installed by a professionally qualified technician, **who shall take the responsibility of observing all local and/or national laws published in the Official Journal, as well as applicable technical standards.**

3.3 - PREVENTIVE SYSTEM VERIFICATION AND ADJUSTMENT OPERATIONS

Before installing this appliance on old systems, check that:

- The chimney is suitable for appliances with condensation, at combustion products temperatures, calculated and built in compliance with the standards in force in this regard.
Is as straight as possible, airtight, insulated, and has no obstructions or constrictions.
- The chimney is equipped with a fitting to drain condensate.
- The boiler room is equipped with a duct to drain condensate produced by the boiler.
- The electrical system has been set up by a qualified technician in compliance with the rules in force.
- The rate, head and direction of the flow of the circulation pumps are appropriate.
- The fuel adduction line and the tank, if any, are made according to relevant standards in force.
- The expansion vessels can fully absorb dilation of the fluid in the system.
- The system has been cleaned from sludge and scaling.

3.4 - PACKAGING

The boiler **MODULEX** is supplied assembled in a sturdy cardboard box.



After removing the two straps, remove the cardboard from the top and ensure the integrity of the contents.



Keep the packaging material (cardboard box, straps, plastic bags, etc.) **out of the reach of children as they are potential sources of danger**. Unical will not be held liable for damage to persons, animals or objects due to failure to comply with the above instruction.



OBLIGATION!
wear protective gloves

- Transport the boiler using suitable transportation means.
- Protect all parts against impacts if they must be transported.
- Follow the transport instructions on the packaging.
- The boilers must always be lifted and carried with a carrying trolley or equipment suitable for transport.

To remove the boiler from the pallet, it is necessary to have a **rocker crane**, to avoid damage during gripping.

- Remove the casings and harness with the straps "A", taking care to pass the straps on the load-bearing crosspieces of the frame
- Tie the straps to the rocker arm "B", operating with caution.

the box contains:

Modulux EXT	A	B	C	Gross Weight
	mm	mm	mm	kg
348	1263	1120	1515	585
440	1263	1120	1515	585
550	1531	1120	1515	643
660	1531	1120	1515	707
770	1799	1120	1515	806
900	1799	1120	1515	858

on the left side of the boiler:

- The flue gas exhaust manifold
- **A cardboard box containing:**
 - Gasket between pan and terminal.
 - Collar gasket (Ø 250) Ø 300.
 - Two elbows + a Tee + a plastic condensate drain plug
 - The screws necessary for fixing the flue gas terminal
- The sensors: external, heater.
- The flue inspection cap
- Sheet and cable glands for power supply output

- **A cardboard box containing:**

The flanges

Inside the rear side casing:

- The condensate drain trap pipes (1 m)

Above the boiler cover:

A plastic bag containing:

- Instruction manual for the installation and maintenance technician
- Ufly control unit operating manual
- BCM 2.0 manual
- Hydraulic test certificate
- Certificate of conformity
- Warranty certificate (IT only)
- Warranty extension 10 A (IT only)
- INAIL certificate (IT only)
- Spare parts coupon (IT only)

- Dowels to lock the fan set in raised position (use only for models 100 ÷ 350 kW)

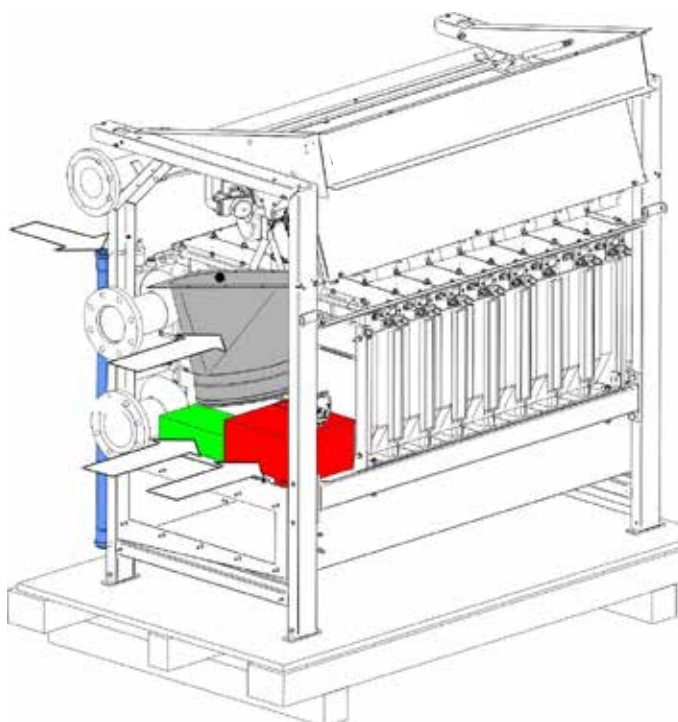
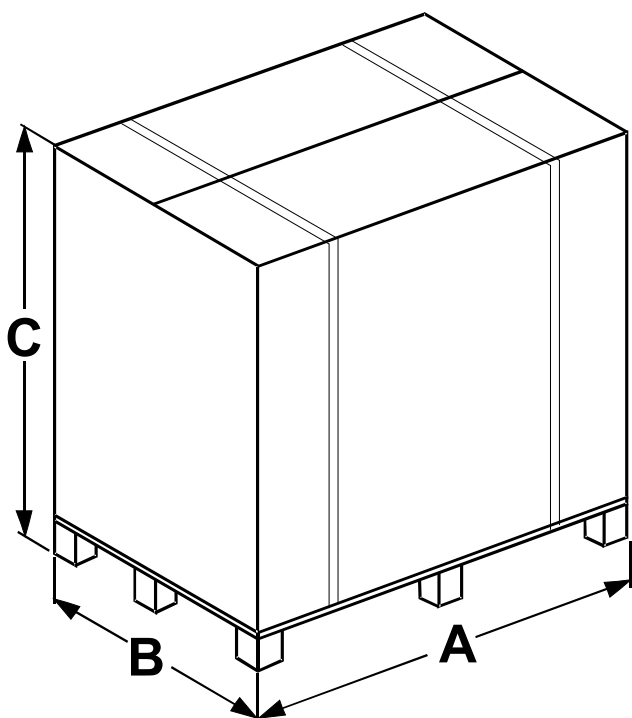

3.4.1 - UNLOADING AND REMOVING THE PACKAGING



ATTENTION!
Handling with forklift or strap hoist,



ATTENTION!
Strap passage points for lifting. The straps must be mounted on the load-bearing crosspieces.

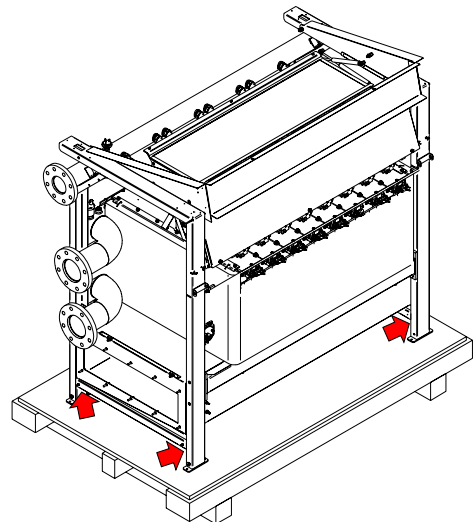
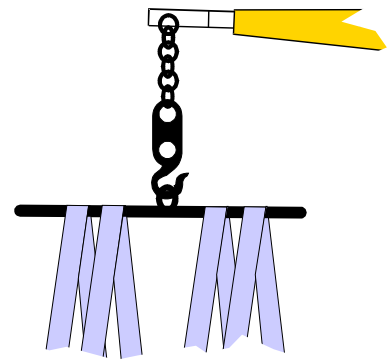
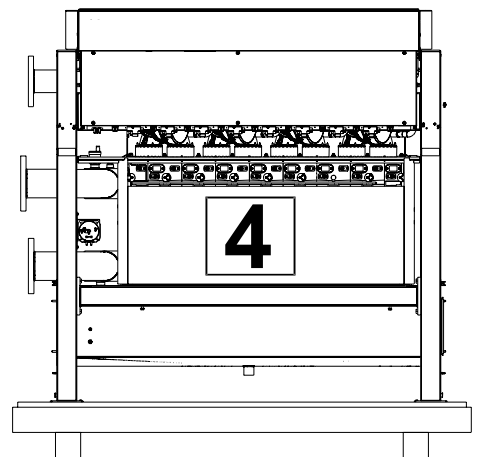
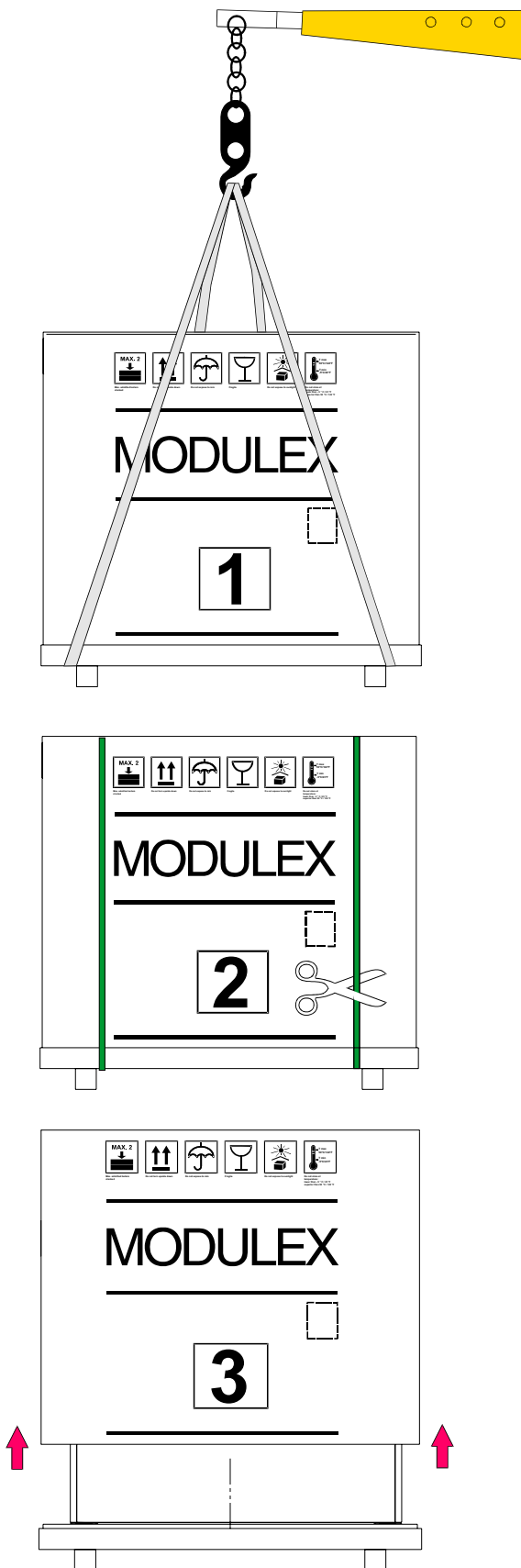

3.5 - POSITIONING IN THE BOILER ROOM

Special attention must be paid to the standards and local laws with regard to boiler rooms, especially the minimum distances that must be kept free around the boiler.

Installation must comply with the provisions in the most recent standards and laws in force with regard to boiler rooms, installation of heating systems and domestic hot water production, ventilation, suitable chimneys to drain combustion products from condensate boilers and anything else applicable.

The boiler can be placed on a flat and sufficiently sturdy base, with a size, in the plan, not inferior to that of the boiler and at least 100 mm high (see figure) in order to be able to mount the siphon for condensate draining. As an alternative to this base, a sump can be obtained on the floor, next to the boiler, with a 100 mm depth for housing the siphon (see figure).

When installation has been performed, the boiler must be perfectly horizontal and stable (to reduce any vibrations and noise).



Comply with the minimum clearance distances in order to execute normal maintenance and cleaning operations.

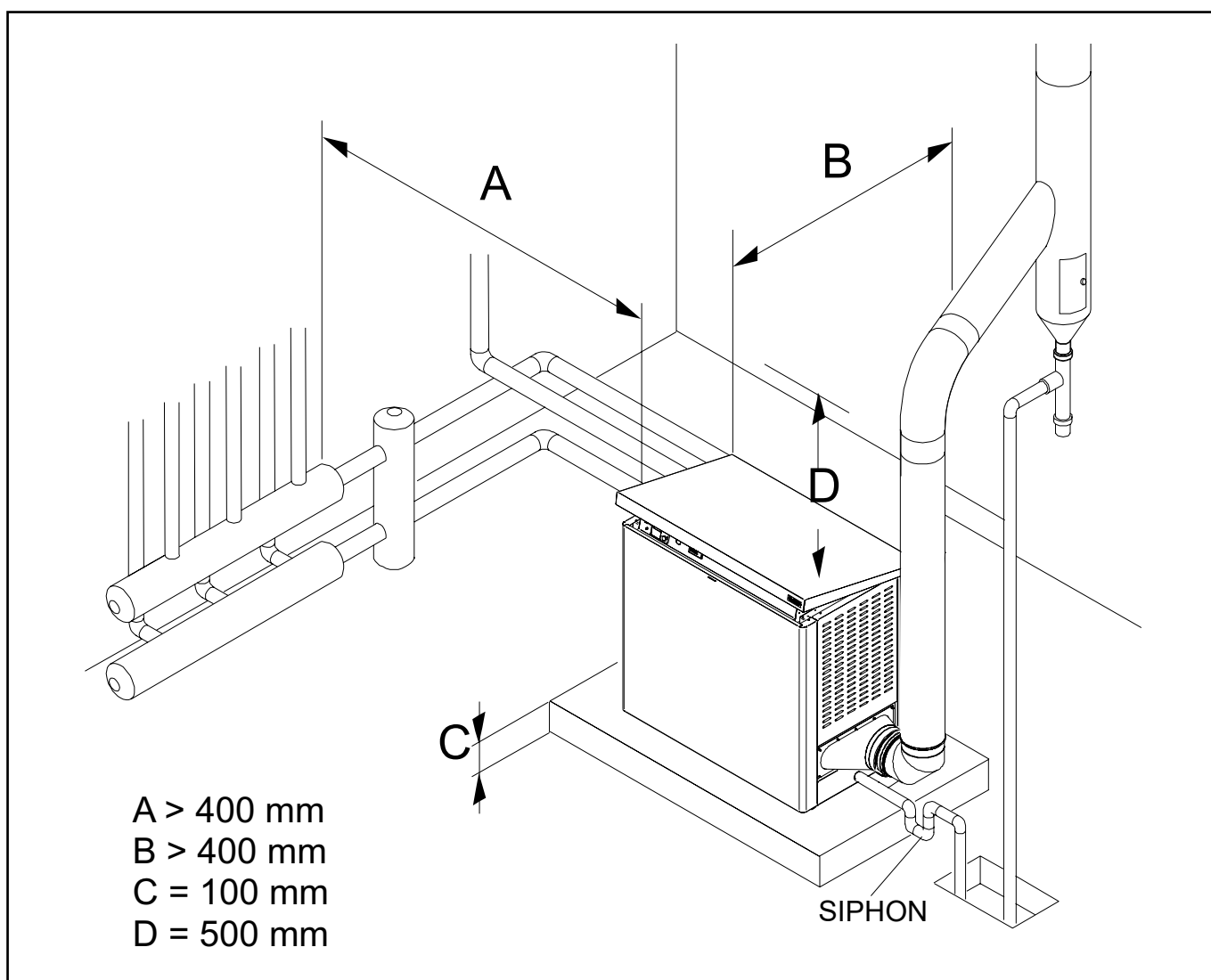

3.6 - FLUE GAS EXHAUST PIPE CONNECTION

To connect the flue gas exhaust pipe, local and national standards must be observed

The boiler is type approved for the exhaust configurations listed below:

B23P ATTENTION
For this type of connection, the room follows the same installation rules for boilers with natural draught.

Connection to a combustion products evacuation pipe outside the room; the combustion air is taken directly from the room where the appliance is installed.

C63 ATTENTION
For the **C63** configuration, you must order the optional air intake kit, which contains the installation instructions.

Separate combustion air intake and combustion products evacuation pipes. (Commercial accessories)

HEAD AVAILABLE AT THE BASE OF THE CHIMNEY	
D (Drain)	I (Intake)
$\Delta p = 100 \text{ Pa}$	-

The maximum permitted length of the pipes is determined by the head (Δp) available at the base of the chimney.

HEAD AVAILABLE AT THE BASE OF THE CHIMNEY
D (Drain) + I (Intake)
$\Delta p = 100 \text{ Pa}$

The maximum permitted length of the pipes is determined by head (Δp) available at the base of the chimney.

ATTENTION:
for **B23P** types of connection, the room follows the same installation rules for natural draught boilers.

ATTENTION:
The chimney must comply with the standards in force.

3.6.1- MANIFOLD CONNECTION EXHAUST PIPE

Use the nuts and washers contained in the bag to fix the flue gas exhaust manifold.

The flue gas inlet must be positioned on the first straight section within 1 metre from the boiler. To create the flue gas inspection inlet, make one $\text{Ø} 21 \text{ mm}$ hole in the flue gas outlet pipe and fit the inspection inlet following the indicated sequence.

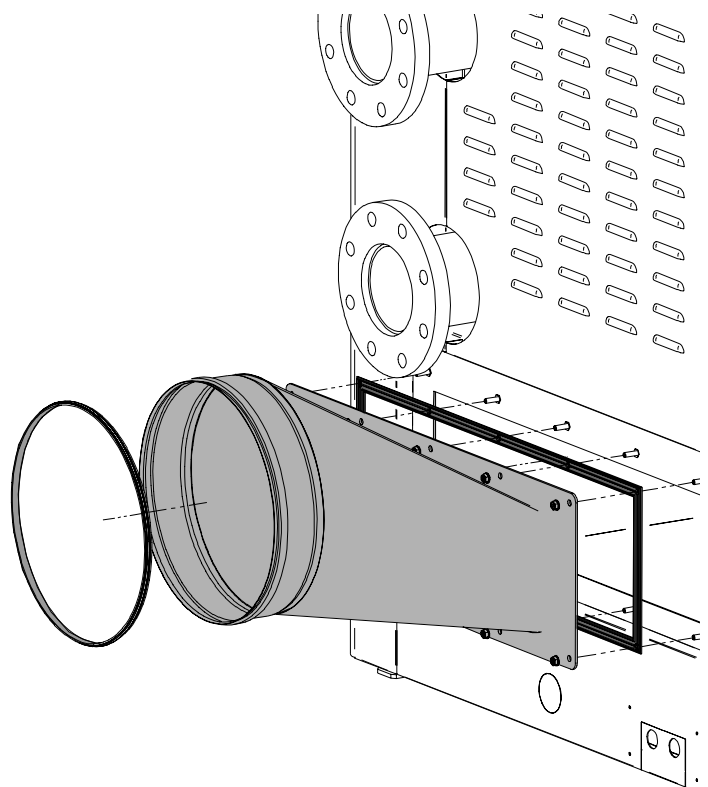
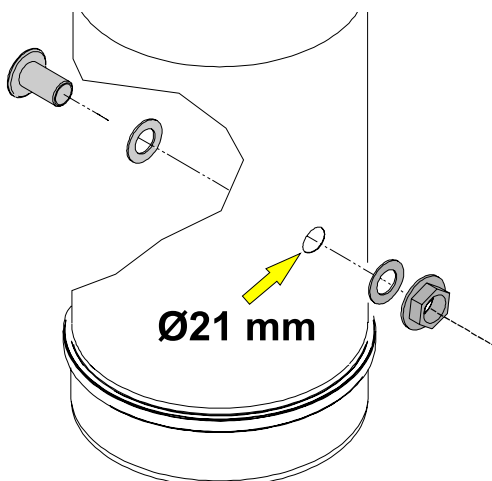

3.7 - BOILER CONNECTION

The MODULEX boiler leaves the factory ready for hydraulic (flow and return), gas connections on the left side of the boiler. To fix the flue gas exhaust manifold, use the screws and gaskets contained in the accessory kit box and a 10 mm socket wrench.

The flue gas manifold is set-up on the LEFT SIDE, the outlet can also be set-up on the RIGHT and REAR SIDE.

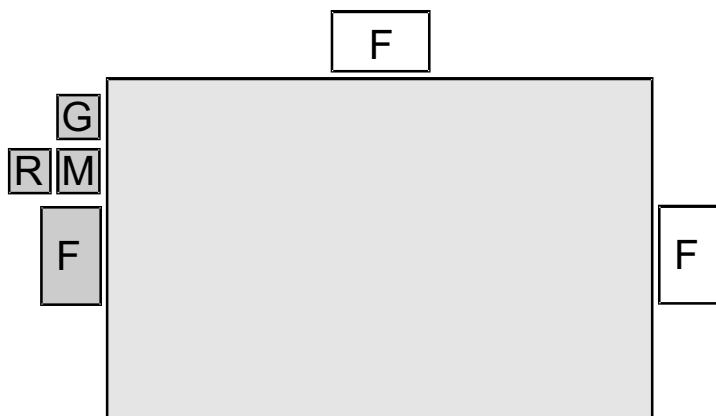

Collector mounted on the first and last element of the flow manifold \varnothing 18 (A), inside \varnothing 27 (B)
Gaskets mounted on all other elements (C).

Collectors and Gaskets

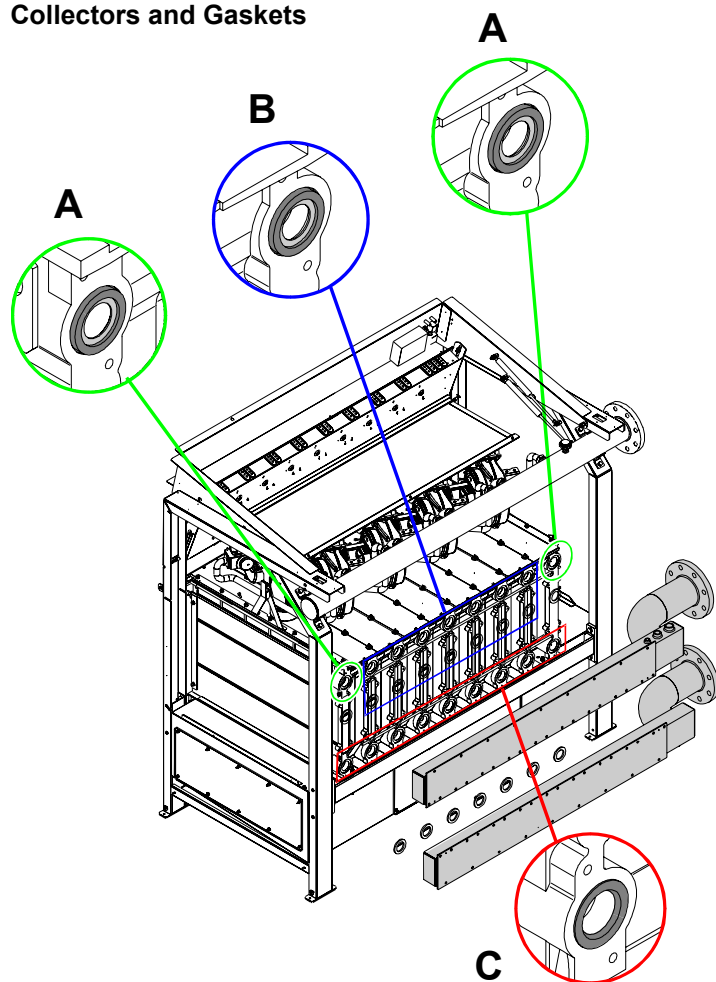

3.8 - CONNECTION

G	GAS	G 3"
---	-----	------

M	FLOW	G 4"
R	RETURN	G 4"



Danger!

The gas must be connected only by a qualified installer who must respect and apply the requirements set forth by relevant laws in force and by the local prescriptions of the supply company. Incorrect installation can cause harm to persons and animals and damage property for which the manufacturer shall not be held liable.



If you smell gas:

- a) Do not operate electrical switches, the telephone or any other object that may cause sparks;
- b) Immediately open doors and windows to create air current to air out the room;
- c) Close the gas valves.
- d) Request the intervention of professionally qualified personnel.



Make sure that the system pipes are not used as earthing electrodes of the electric or telephone system. They are absolutely not suitable for this type of use. Serious damage could result for the piping, boiler and radiators in a short amount of time.



ATTENTION!

IT IS STRICTLY FORBIDDEN TO FIT SHUT-OFF DEVICES ON THE GENERATOR BEFORE THE SAFETY DEVICES.



As a precaution against gas leaks, we recommend installing a monitoring and protection system consisting of a gas leak detector coupled with a shut-off solenoid valve on the gas feed line.

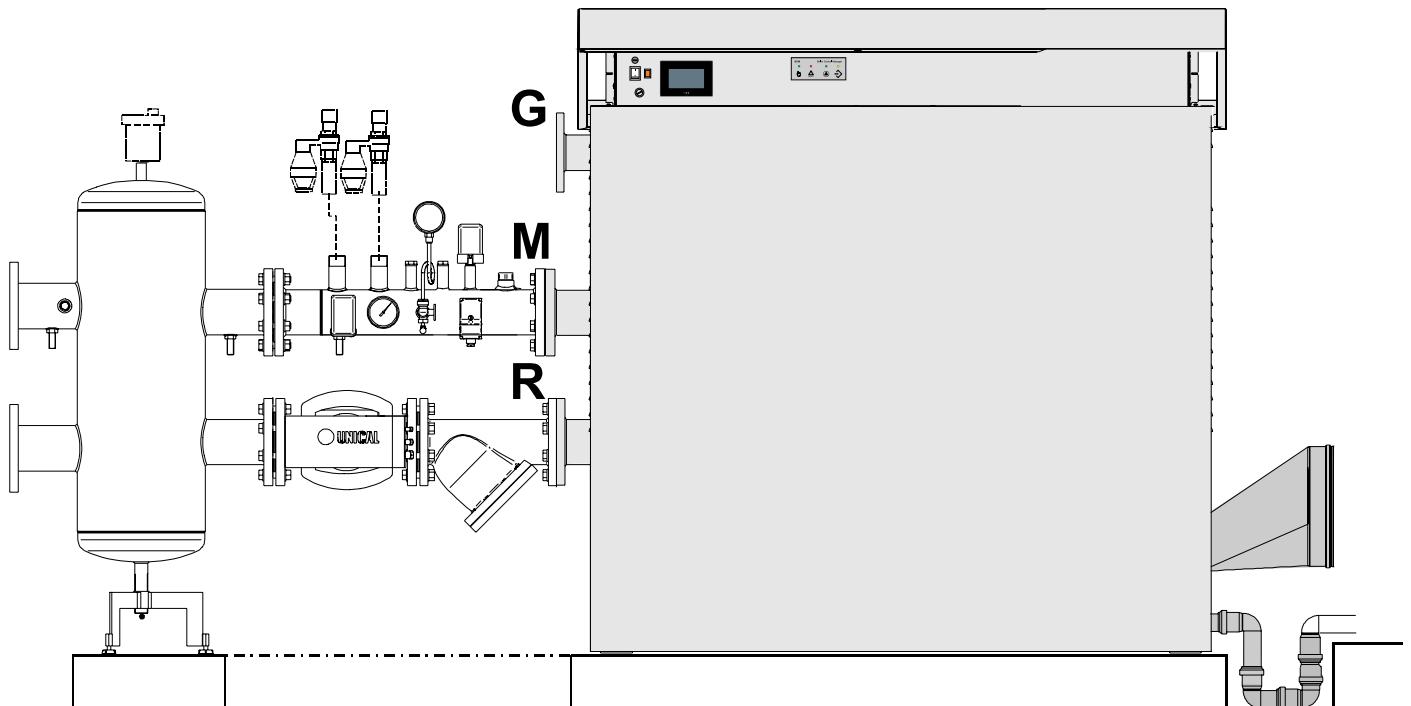

Condensation drain

The boiler, during the combustion process, produces condensation that, through pipe "A", flows into the trap.

The condensation that forms inside the boiler flows into a suitable drain via pipe "B".



Danger!

Before commissioning the appliance:

- check that the siphon is assembled correctly
- fill the siphon through the filler cap C and check correct drainage of the condensate

If the appliance is used with an empty condensation drain trap, there is an intoxication hazard due to the release of exhaust gases.

The outlet of the condensate drainage pipe is towards the connection side of the flue gas box manifold, removing the pre-cut part on the covering panel.

FRONT SIDE

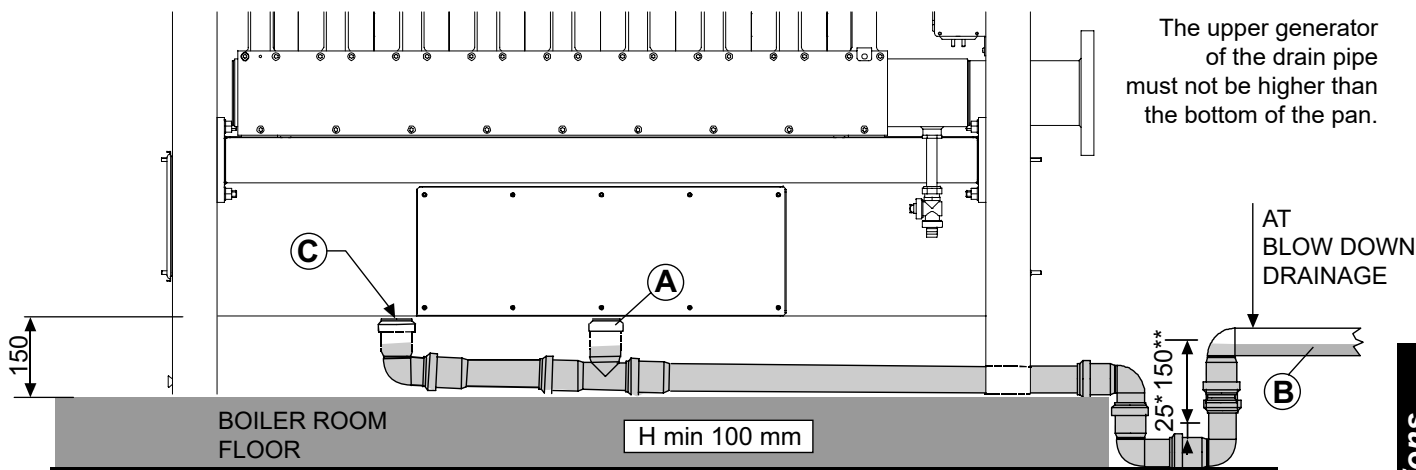

- * Minimum safety siphon set by the standard
- ** Minimum head with boiler running at maximum power.



If you do not want to or cannot create a base, the boiler can be mounted at ground level and a sump at least 100 mm deep can be made to house the siphon



The connection between the appliance and the domestic wastewater system must be made in compliance with the specific reference standards.



NOTE!
For further details refer to the Technical Information from the website

3.9 - FILLING AND EMPTYING THE SYSTEM



When all system connections have been completed, the circuit can be filled.

To fill the system, you must provide a filling valve on the system's return.

EXAMPLE OF THE SYSTEM'S LOADING UNIT

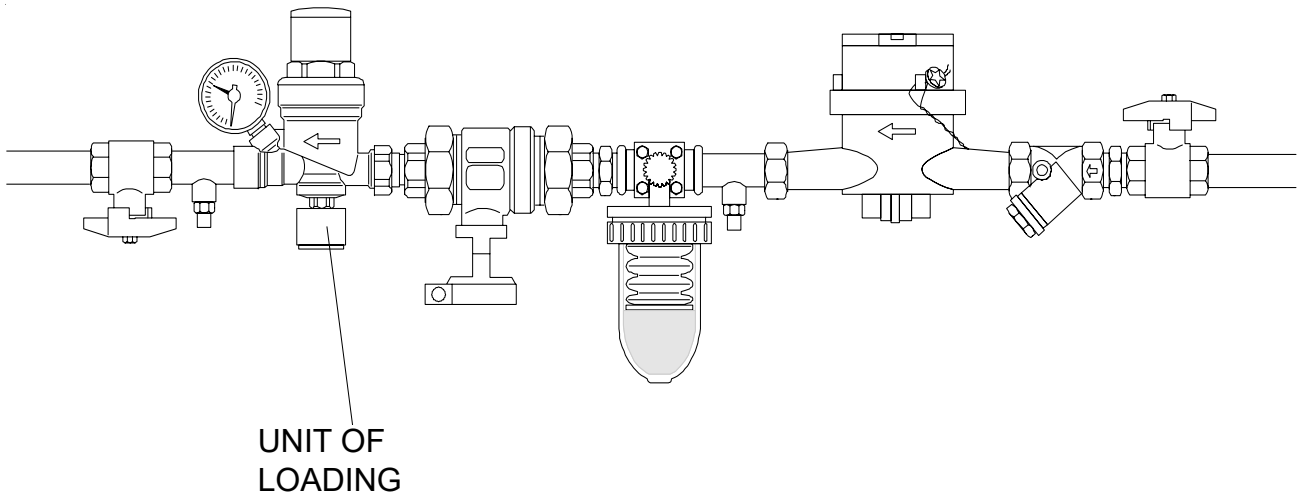

To fill the system, you must provide a filling valve on the heating circuit, or use the optional accessories.



The boiler is equipped with its own drain valve, **14**. This valve can **never** be used to drain the system since all the dirt in the system can accumulate in the boiler and jeopardise its proper operation. Therefore, before using the drain valve, make sure the system's check valve, which is situated under the pump, has been closed.

The system must be equipped with its own drain valve, which is to be suitably sized according to the system's capacity.

PAGE LEFT INTENTIONALLY BLANK

3.10 - ELECTRICAL CONNECTIONS



Danger!

Before performing connections or any type of operation on electrical parts, always disconnect the electrical power and make sure that it cannot be reconnected accidentally.

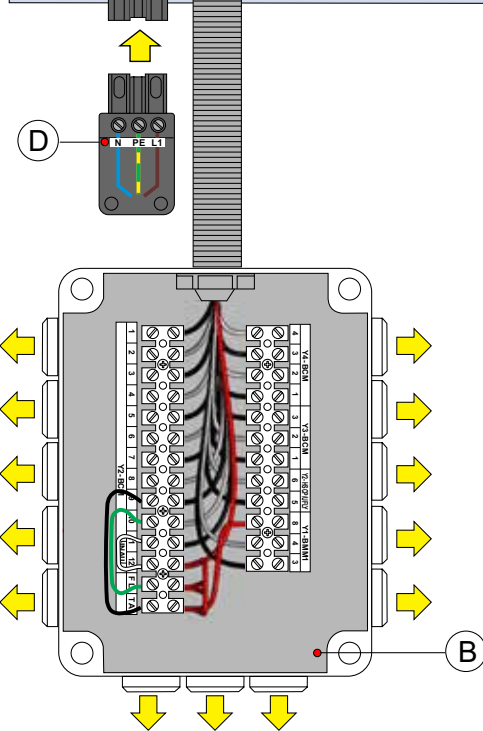
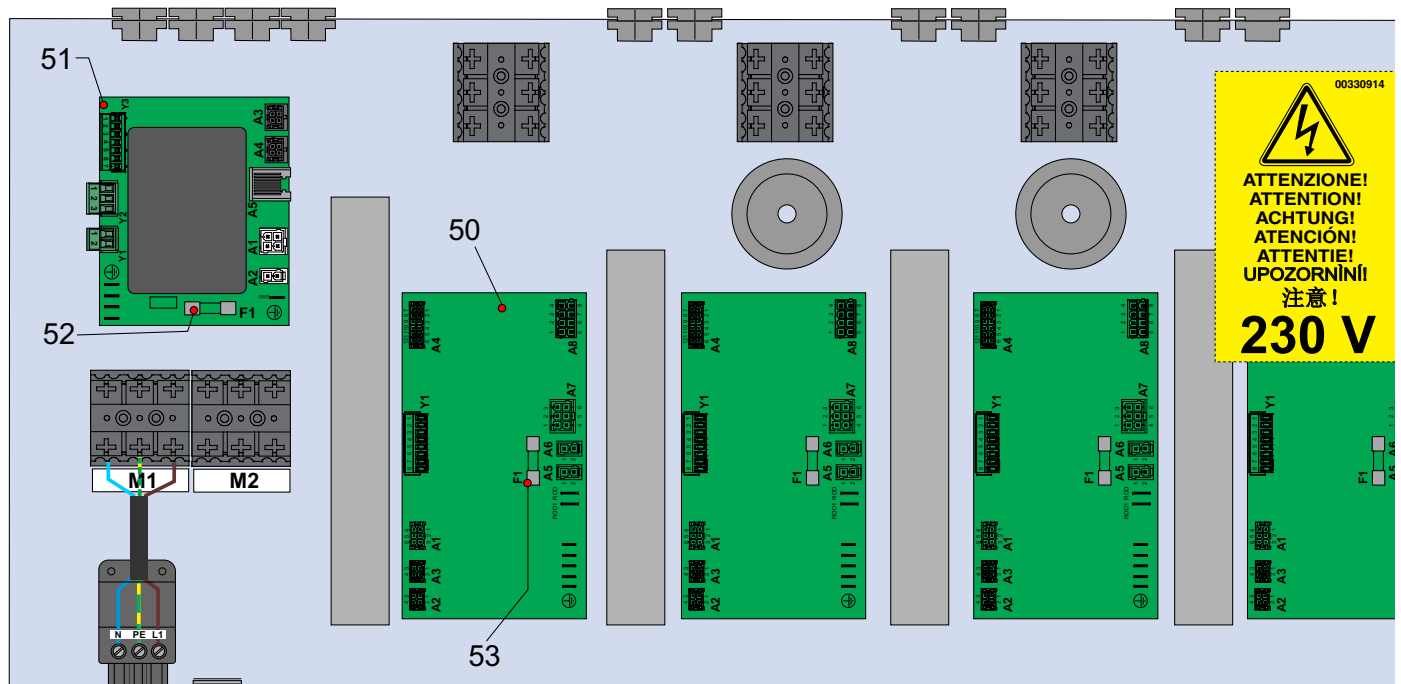
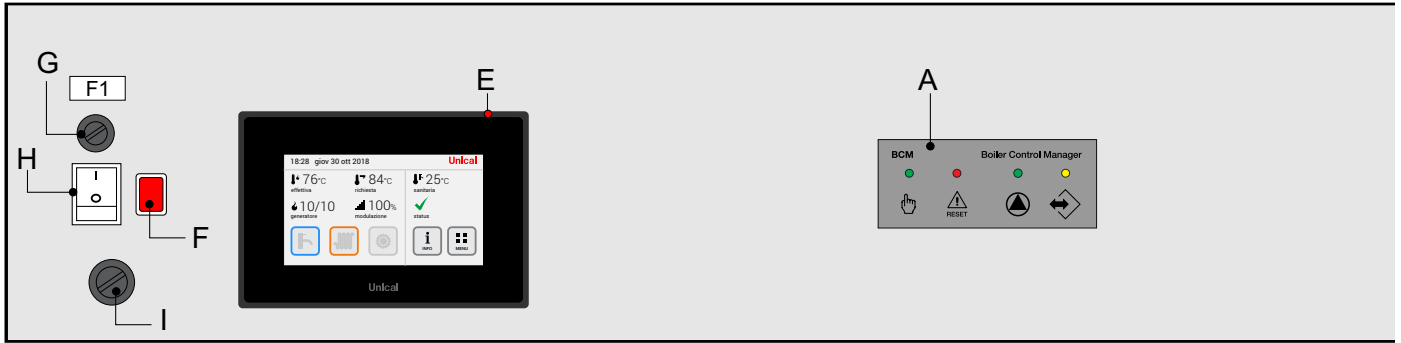

KEY	
No.	Description
A	BCM Boiler controller
B	Services connection return terminal board
D	Wieland mobile pow. supp. socket 230 V - 50Hz
E	Ufly P heating controller
F	LTGL TLG triggering lamp
G	F1 Power supply fuse 6.3 AT 250V
H	Boiler Main switch
I	LTGL Manual reset main limit thermostat
50	BMM Burner management board
51	Power supply board
52	F1 Power supply fuse 6.3AF 250V
53	F1 BMM Board Fuse 6.3AF 250V



Danger!
Only a qualified technician may perform the electrical installation.



Electrical connection to the main power supply.

This connection must be made up to standard, as required by regulations in force.



Remember that a bipolar switch must be installed on the boiler power line with over 3 mm between contacts, easy to access, making maintenance quick and safe.

Electric power supply connection



The power supply of the boiler, single-phase 230 V - 50 Hz, must be made with H05VV-F type three-pole cable (PHASE - NEUTRAL - EARTH) with 0.75 mm section up to 1.5 mm.



ATTENTION!

Respect the PHASE and NEUTRAL polarity since flame detection is Phase Sensitive.



ATTENTION:

The 230 V cables must run far apart from 24V cables.

- Make the power supply connection on the "D" plug, supplied with the boiler.

N.B. 24 V - 230 V output - Keep the 2 voltages separate



NOTE:

The boiler is set up for direct flow and storage tank management.

If **Stemp. ACC** is connected automatically, DHW is activated, which will have priority management with regard to direct flow through the pumps shown below.

Should additional services be requested (storage tanks, mixed areas, solar, etc), you must purchase **SHC** multifunction kits for full control through the **Ufly P** heating control.

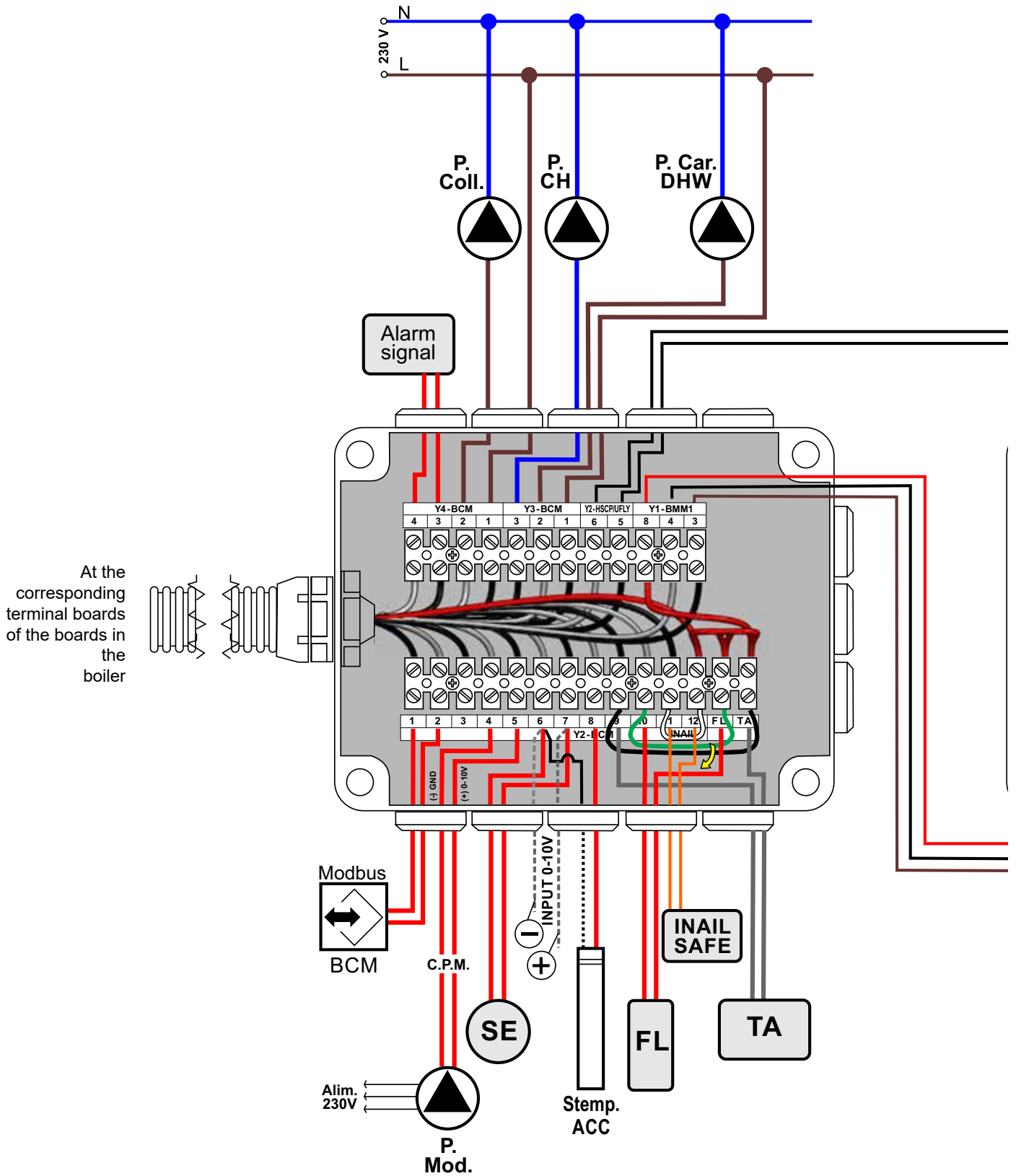

Connections for:		
	Y2 BCM	
Modbus BCM		Remote boiler control
A	1	A (1) Data connection
B	2	B (2) Data connection
P. mod	4 - 5	Modulating heating pump
SE	6 - 7	External sensor
- / +	6 - 7	0 / 10 V signal contact
Stemp ACC (*)	6 - 8	Storage Tank Temperature Sensor
FL	FL - 10	Flow switch (remove jumper)
INAIL	11-12	Safety devices (remove jumper)
TA	TA - 9	Room thermostat / Clock remove jumper

	Y4 - BCM	
Alarm signal (**)	3 - 4	Alarm / signal contact (NO potential-free contact)
P. Coll.	1 - 2	Manifold pump (primary loop)
	Y3 - BCM	
P. CH	1 - 3	Heating circuit pump
P. Car DHW	1 - 2	Storage Tank loading Pump
	Y2 - UFLY	
Modbus Ufly		Remote Temperature Control
A	5	A (5) Data connection
B	6	B (6) Data connection
	Y1 BMM1	
SHC (***)	8 - 4 - 3	Optional multifunction module (to be inserted in the box cover)

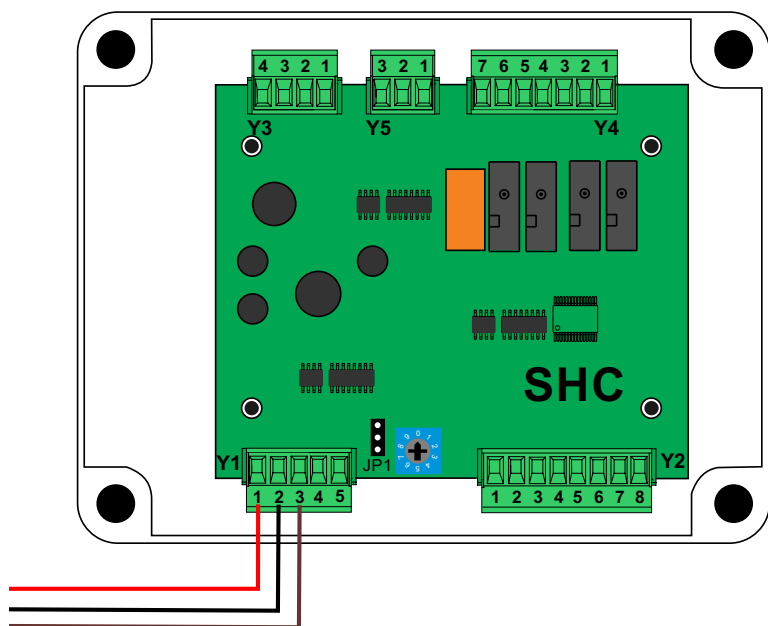
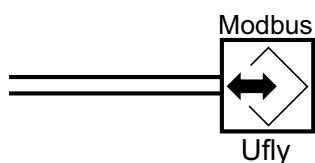

(*)
If the storage tank temperature sensor is connected, DHW service is automatically activated on boiler power supply. Parameter (803) **Srv** (is automatically updated).

(**)
Relay contact that closes when in alarm mode

(***)
SHC optional
The system can power only one SHC module. If you need to have more than one SHC module, they must be placed externally in a dedicated electrical panel and powered with their own power supply unit.



The **BCM** and **SHC** relay contacts support pumps with **max. 4A absorption**.



Modbus BCM can be used for control from building automation, can also be connected with Modbus Ufly to have a single bus.

Installation instructions

PAGE LEFT INTENTIONALLY BLANK

Connection diagram example:

Power supply, INAIL, Modulating pump, External sensor, Flow switch

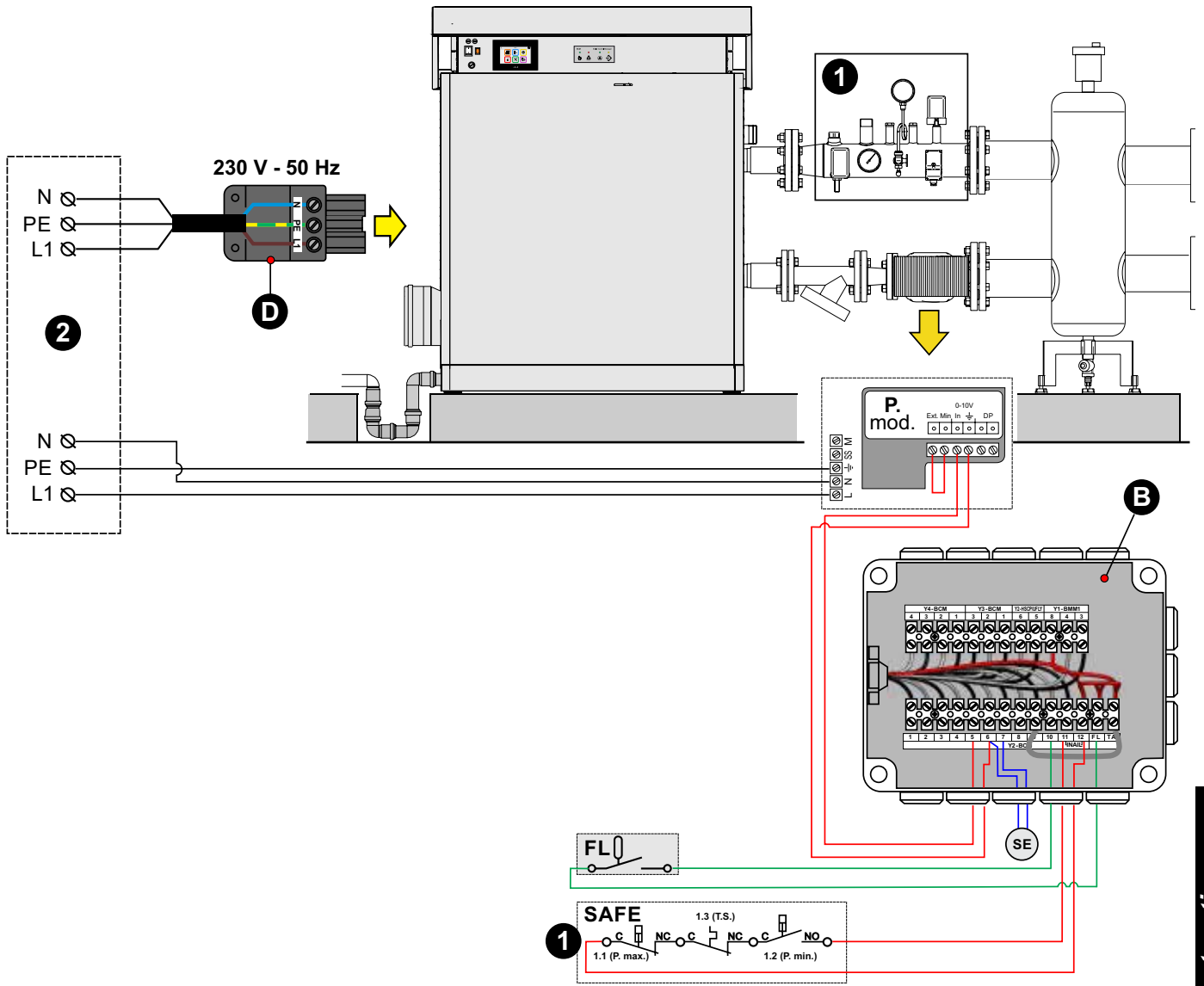

Installation instructions

KEY	
No.	Description
1	INAIL - Safety bodies
2	Main electrical panel (not supplied)
B	Services connection return terminal board
D	Wieland mobile pow. supp. socket 230 V - 50Hz
FL	Terminals for Flow switch
SE	Terminals for external Sensor
SMG	Global flow sensor
P_on_off	Manifold Pump Connections (on_off)
P_mod	Modulating pump Connections

Connection diagram example: 2 modulex in pack managed by cascade manager

primary loop

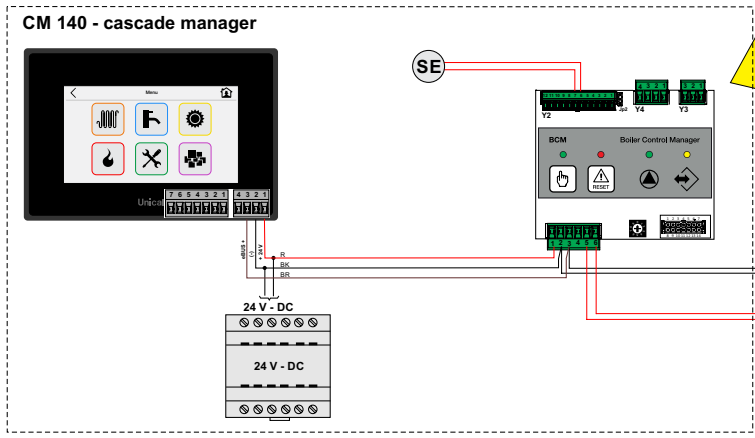
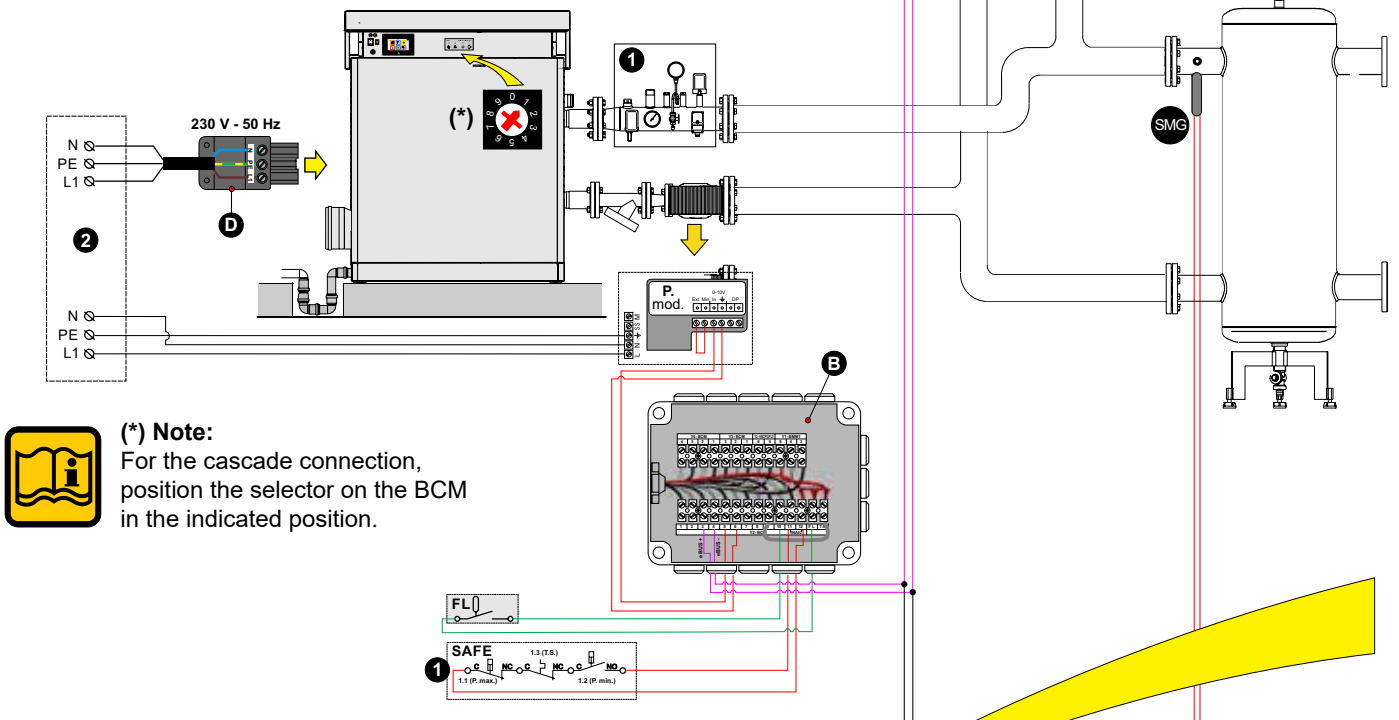
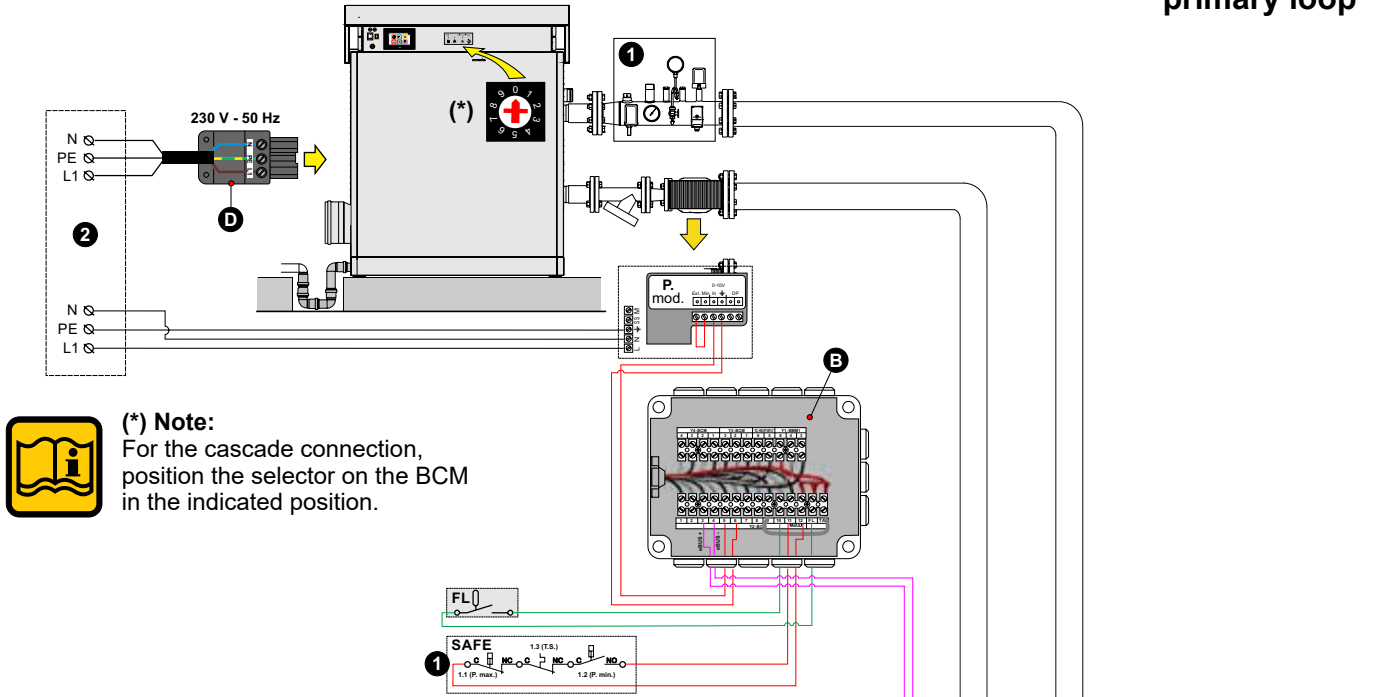

with direct zone and DHW production.

secondary loop

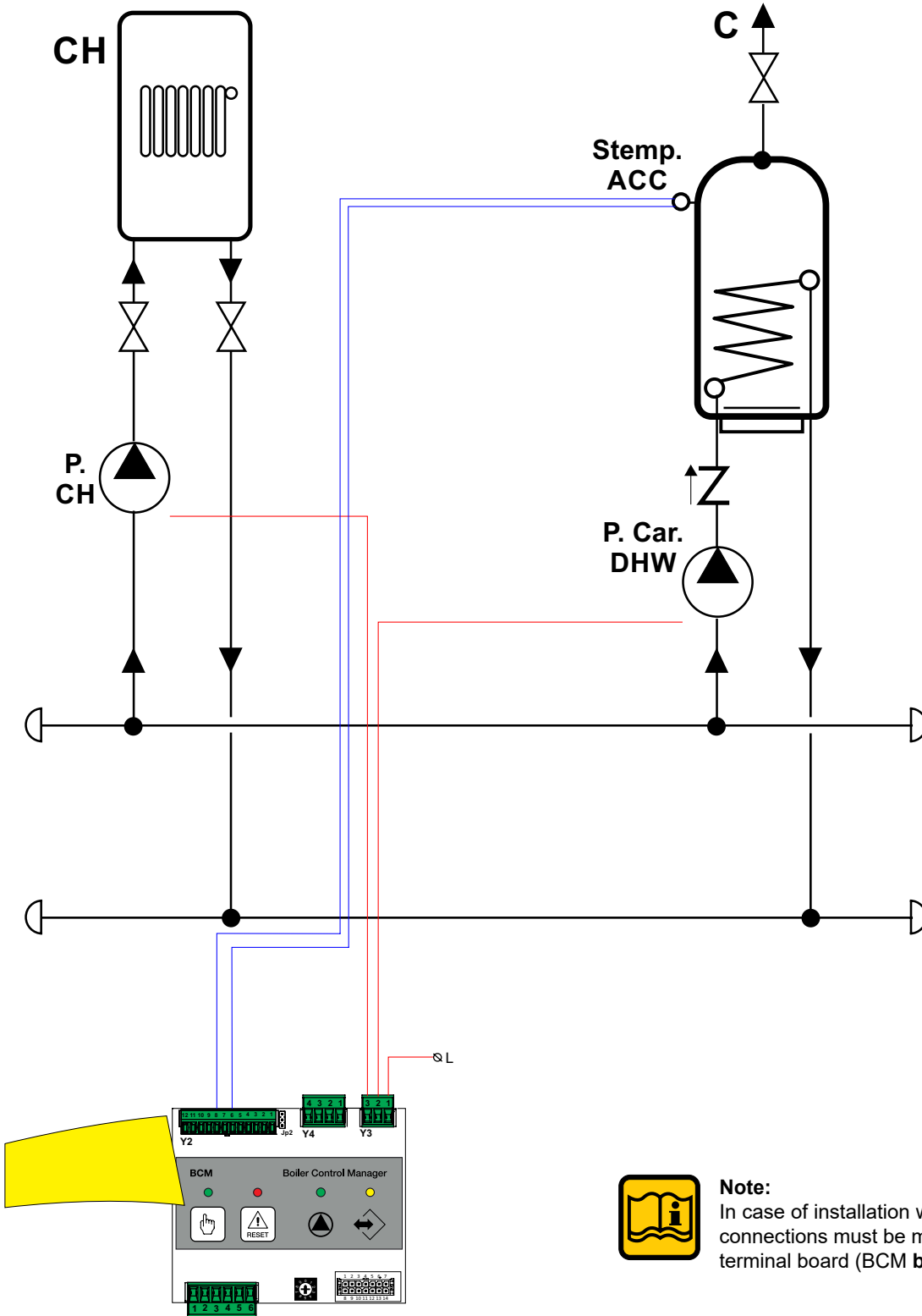

Note:
In case of installation with single boiler, the above connections must be made on the return terminal board (BCM board) inside the boiler.



Note:
To configure cascade boiler management parameters, refer to the specific installation manual.



Note:
Illustrative diagram, consider the total nominal flow rate, any check valves (not supplied), and verify the efficiency of the flow switches at each flow rate in modulation.

Wilo Stratos modulating pump setting (ext. input enabling 0 - 10 V)

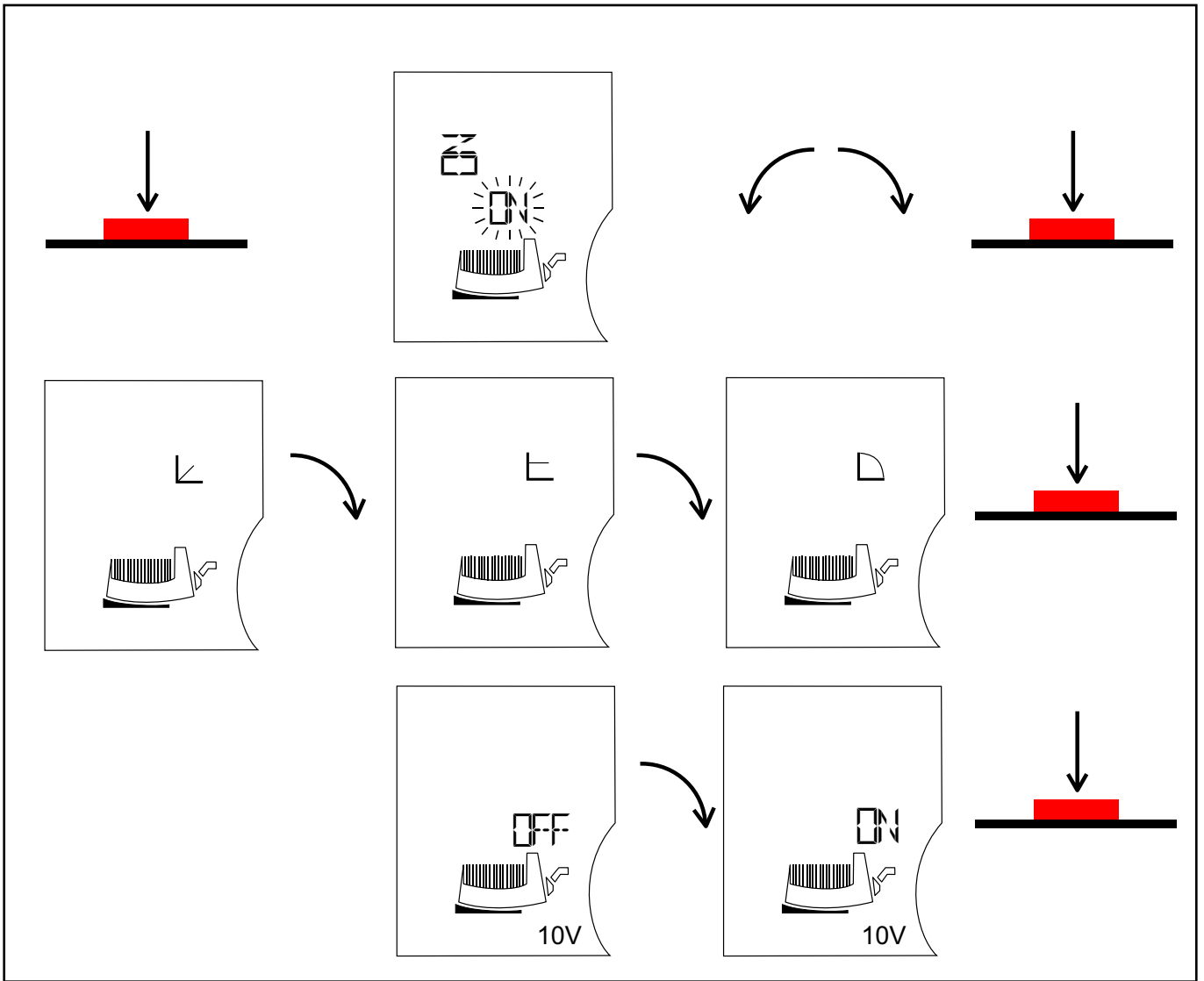

3.11 - COMMISSIONING



Commissioning must be done by professionally qualified personnel. Unical will not be held liable for damage to persons, animals or objects, due to failure to comply with the aforesaid instructions.

Before commissioning the boiler, check the following:

does the installation meet the specific standards and regulations in force, both relating to the gas part as well as the electrical part?	<input type="checkbox"/>
do the combustion air intake and flue gas exhaust take place properly according to what is defined by the specific rules and regulations in force?	<input type="checkbox"/>
is the fuel supply system sized according to the capacity required by the boiler? Is it equipped with all safety and control devices required by the standards in force?	<input type="checkbox"/>
is the power supply of the boiler 230V - 50Hz?	<input type="checkbox"/>
has the system been filled with water (approximately 0.8/1 bar pressure on the pressure gauge with the pump stopped)?	<input type="checkbox"/>
Has the condensation drain trap been filled with water as indicated in chapter 3.8?	<input type="checkbox"/>
are any system shut-off gate valves open?	<input type="checkbox"/>
does the gas to be used correspond to the boiler calibration gas?: otherwise, perform the boiler conversion in order to use the gas available; this operation must be carried out by technical staff qualified in compliance with the standards in force;	<input type="checkbox"/>
is the gas supply valve open?	<input type="checkbox"/>
has the system been checked for gas leaks?	<input type="checkbox"/>
is the outside main switch ON?	<input type="checkbox"/>
is the system safety valve efficient and is it connected to the drains? is the condensation drain trap connected to the drains?	<input type="checkbox"/>
has the system been checked for water leaks?	<input type="checkbox"/>
are the ventilation conditions and minimum distances to perform any maintenance ensured?	<input type="checkbox"/>
have the GAS, HEATING and DOMESTIC HOT WATER pipes been cleaned thoroughly with products suitable for each circuit?	<input type="checkbox"/>
has a surveillance and protection system against gas leaks been installed? (Optional)	<input type="checkbox"/>
are the system pipes NOT used as the electrical system earthing?	<input type="checkbox"/>
has the system been sized properly bearing in mind the radiator pressure drops, thermostatic valves, radiator stop valves?	<input type="checkbox"/>
has the operator been trained and has the documentation been supplied?	<input type="checkbox"/>
Please tick the completed operations	



Switching boiler on and off

To switch the boiler on and off, see the Ufly regulator manual

3.12 - MEASUREMENT OF THE COMBUSTION EFFICIENCY DURING INSTALLATION Generator Menu

3.12.1 - CALIBRATION FUNCTION (CHIMNEY SWEEP)



ATTENTION!
Function reserved for After Sale Service Centres only.



ATTENTION!
These functions are explained in chapter 2.9 (Burner menu) of the Ufly P. TOUCH CONTROL installation and maintenance manual.

3.12.2 - POSITIONING THE SENSORS

To determine the combustion efficiency one must make the following measurements:

- measurement of the combustion air temperature
- measurement of the flue gas temperature and content of CO₂ taken in the relevant hole 2.

Take the measurements with the generator in steady state conditions (see par. 3.12.1).



All boilers leave the factory already calibrated and tested. However, if the calibration conditions should be modified, it is necessary to recalibrate the gas valve.

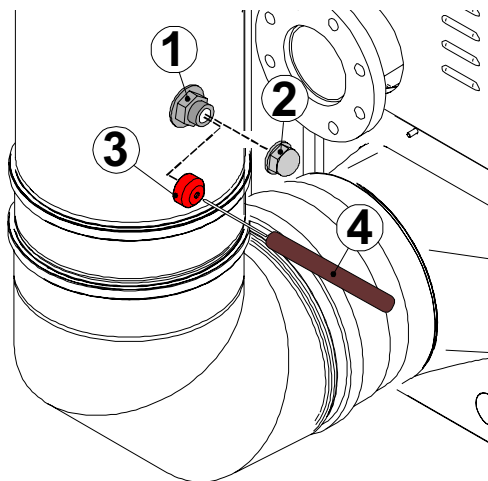

ATTENTION!

Remove cap 2, fix the red cap 3 to the flue gas inlet 1. Insert the CO₂ analysis sensor 4 in the cap hole. Perform the measurement. Remove the cap and close the flue gas exhaust inlet with the specific cap 2.

3.13 - ADJUSTING THE BURNER



All boilers leave the factory already calibrated and tested, however, if required, recalibrate the gas valves (MODULE 1, MODULE 2, etc.)



The following instructions are intended exclusively for **authorised service personnel**.

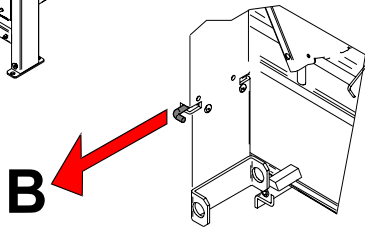
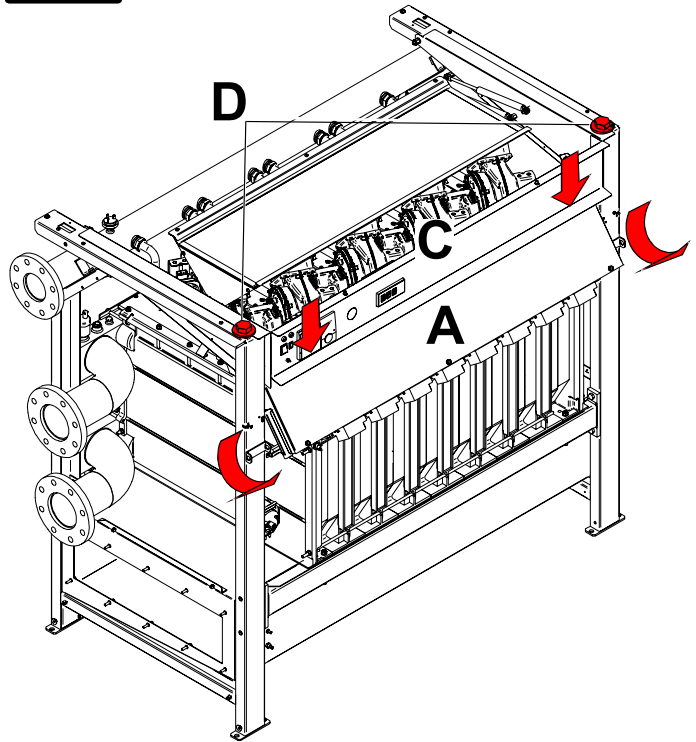
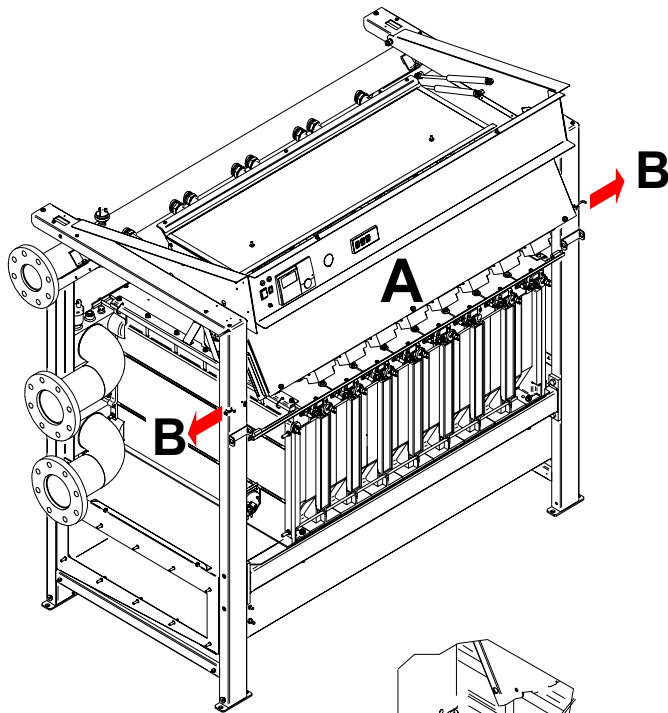

ATTENTION!

To access the gas valves more easily, release the electrical panel "A" by means of the springs "B" (right and left). Slightly turn the electrical panel "A" and lower the tilting panel "C".

Fix the tilting panel "C" for the time necessary for the adjustment operation, using the 2 M4 screws + washers "D" (contained in the documentation bag).

- Remove the cap and insert the CO2 analysis sensor in the flue gas sample point of the intake/exhaust terminal, see chap. 3.12.2.

1) Maximum output adjustment

- Operate the boiler in "calibration" mode at MAXIMUM OUTPUT (see 3.12.1)
- Once the burner is on, check that the "MAXIMUM" CO2 output value corresponds to that indicated in the "NOZZLES - PRESSURE" table.
- If necessary, adjust the value by turning the "S" adjustment screw CLOCKWISE to decrease it and ANTICLOCKWISE to increase it (see NOZZLES-CAPACITY-PRESSURE table).

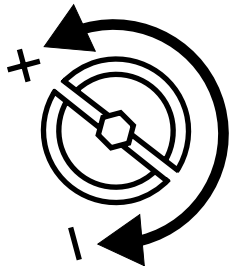
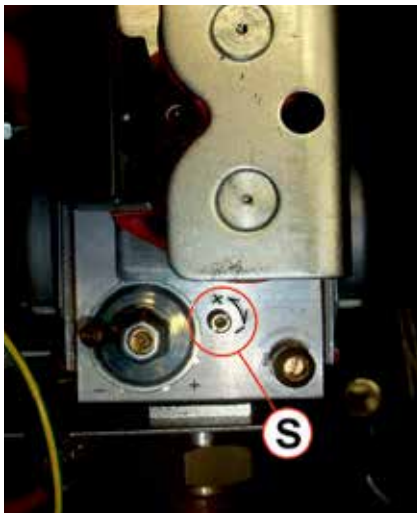

(S)
ADJUSTMENT SCREW
MAXIMUM OUTPUT

2) Minimum output adjustment

- Operate the boiler in "calibration" mode at MINIMUM OUTPUT (see 3.12.1)
- Once the burner is on, check that the "MINIMUM" CO2 output value corresponds to what is indicated in the "NOZZLES - PRESSURE" table.
- If necessary, adjust the value by turning (with a 2.5 mm hex key) screw "R" CLOCKWISE to increase it, ANTICLOCKWISE to decrease it (see NOZZLES-CAPACITY-PRESSURE table).

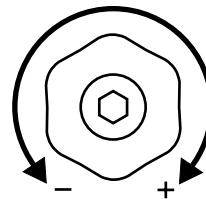
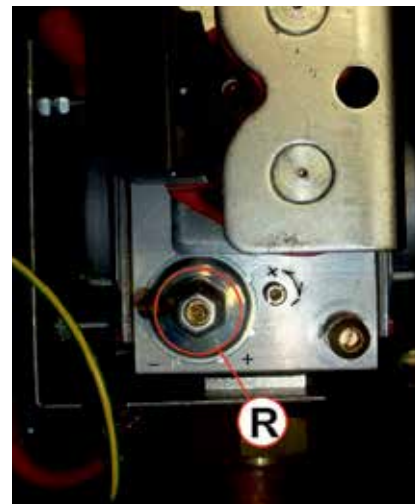

(R)
ADJUSTMENT SCREW
MINIMUM OUTPUT

In case of replacement of the Gas valve or ignition difficulties:

Tighten the maximum adjustment screw "A" clockwise up to the stop, then loosen by 7 turns. Check the boiler ignition, in case of a block, loosen the screw "A" again by one turn, then try igniting it again. If the boiler still stops running, perform the above operations again until the boiler ignites. Now adjust the burner as previously illustrated.

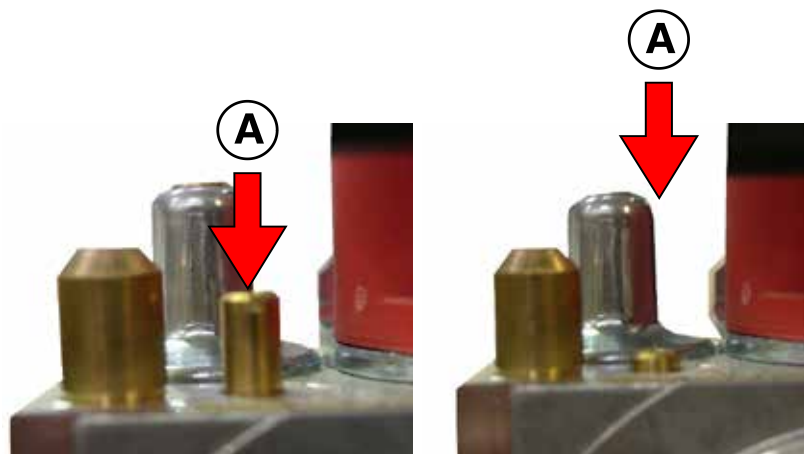

Follow this procedure to also adjust the other modules.

If the capacity read is too low, make sure the power feed and drain system (feed and drain pipes) are not clogged.

If they are not clogged, make sure the burner and/or heat exchanger is not dirty.

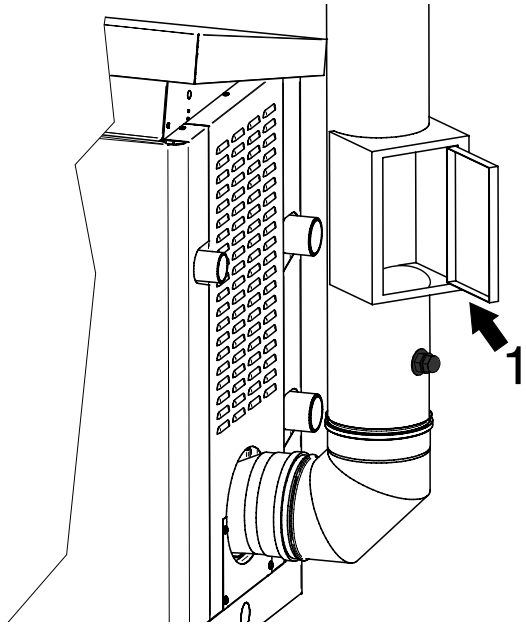

ATTENTION
To calibrate the **VG (Gas Valves)** in the boiler room, follow the procedures below.

The VG must be calibrated with chimney pressure = 0 Pa; for this reason:

- open the smoke duct 1 inspection door, after calibration, restore the door gasket.

INDICATIVE DIAGRAM, REFERRING TO BOILERS MODULEX 150 ÷ 350

C) CONCLUSION OF THE BASIC CALIBRATIONS

- Check the CO₂ values at minimum and maximum levels.
- If necessary, make any adjustments.

- Close the flue gas inspection inlet (1) with the specific cap (2 - 3)



For proper operation, the CO₂ values must be calibrated with particular attention, observing the values indicated in the table.



NOTE: Do not force the end stroke limits of the adjustment screw.

NOZZLES - PRESSURE - CAPACITY TABLE

MODULEX EXT: 440 - 550 - 660 - 770 - 900								
Type of Gas	Supply Press.	Ø Nozzles (mm)	Fan deflector [Ø/mm]	Fan speed		CO ₂ levels		Start. power [%]
	[mbar]			min FL	max FU	[%]		
						min	max	IG
Nat. gas (G20)	20	9	NO	29	96	9.0	9.0	50
Nat. gas (G25)	25	9	NO	28	98	9.1	8.6	50
Nat. gas (G27)	20	9	YES	28	94	9.1	9.3	50
Propane (G31)	37	9	NO	28	90	10.2	10.4	50



MODULEX EXT: 348								
Type of Gas	Supply Press.	Ø Nozzles (mm)	Fan deflector [Ø/mm]	Fan speed		CO ₂ levels		Start. power [%]
	[mbar]			min	max	[%]		
						min	max	IG
Nat. gas (G20)	20	9	NO	29	76	9.0	9.0	50
Nat. gas (G25)	25	9	NO	28	82	9.1	8.6	50
Nat. gas (G27)	20	9	YES	28	94	9.1	9.3	50
Propane (G31)	37	9	NO	28	73	10.2	10.4	50

Installation instructions

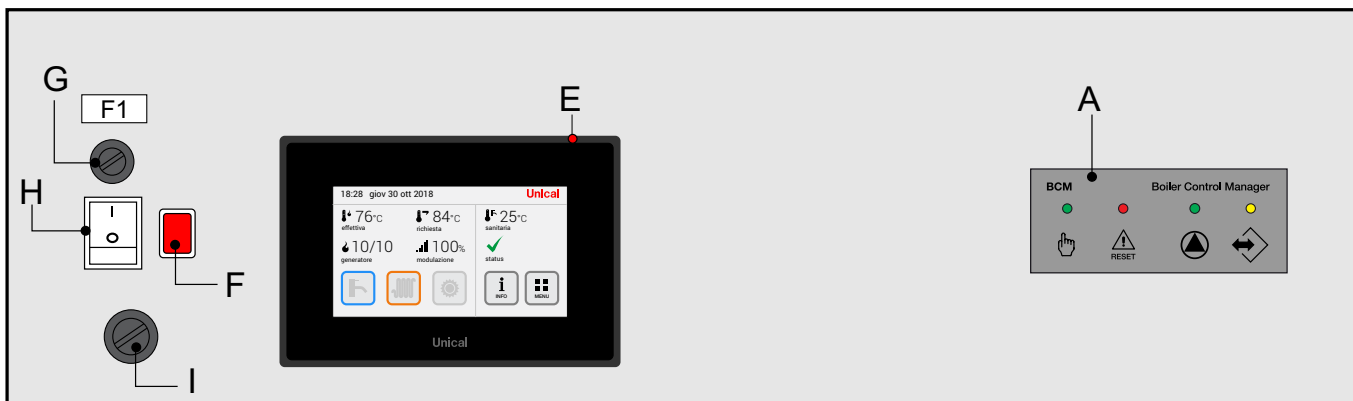
3.14 - EMERGENCY OPERATION AND SAFETY DEVICES



	The BCM prevents system shutdown if the management of the Ufly system or main boiler system is out of service (Refer to the BCM manual)
A	YELLOW LED = flashing (communication between BMM and BCM) ok
	GREEN LED = on (Pump Active)
	RED LED = on (Error code detected)
E	Ufly control panel
F	TLG triggering lamp Main Limit Thermostat
G	Fuse
H	Main Switch
I	TLG Main Limit Thermostat, when it triggers it cuts power to the boiler, the F lamp lights up. To rearm, remove the cap and press.

	NOTE: The devices are positioned under the casing, next to the control unit.
	NOTE: The emergency function only activates the boiler burners at 100% on flow. All system loads, including the manifold pump, must be manually controlled.

Condensate level sensor position



3.15 - PROGRAMMING THE OPERATING PARAMETERS



ATTENTION!
Function reserved for After Sale Service Centres only.

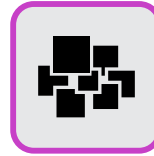

ATTENTION!
These functions are explained in chapter 2.8 (DEVICES menu) of the Ufly P. TOUCH CONTROL installation and maintenance manual.

BMM parameters						
Code	Symbol	Description	Unit	Min.	Max.	Imp. Fab.
803	Srv	Enabled Services		0	1	
48	ChSet	CH#1: Set-point	°C	20	85	
784	BC	Local BUS address		0	7	
816	MI	Modbus Address		1	127	
817	MT	Modbus Time-out	sec.	0	240	
896	TU	°Fahrenheit		0	1	
799	AC	Input 0/10V		0	2	
376	DI1	Programmable Input #1		0	3	
322	Po	Pump: Post-circulation	min.	1	30	
341	PL	Pump: Minimum Control	%	0	100	
313	Pr	Pump: Maximum Control	%	0	100	
31	HL	CH#1: Minimum Set-point	°C	20	85	
39	HH	CH#1: Maximum Set-point	°C	20	85	
792	CHP	CH: Max. Modulation	%	0	100	
619	IG	Ignition Modulation	%	30	80	
527	PU	Fan: PPR		0	3	
486	FP	Fan: Reg. Prop.		0	50	
487	FI	Fan: Reg. Int.		0	50	
489	Fpl	Fan: PWM min.	%	5	15	
337	Fr	Modulation Gradient	%	1.0	100.0	
526	FU	Fan: Max Max.	Hz	50	120	
319	FH	Maximum Modulation	%	1.0	100.0	
346	FL	Minimum Modulation	%	1.0	100.0	
314	Sb	Modulation on Standby	%	0	100	
620	IP	Postpurge: Fan	%	0	100	
617	IGL	Ignition: Mod. Min.	%	0	100	
618	IGH	Ignition: Mod. Max.	%	0	100	
353	HP	CH PID: Proportional	°K	0	50	
354	HI	CH PID: Integrative		0	50	
478	Hd	CH PID: Derivative		0	50	
34	HY	Burner Hysteresis	°K	5.0	20.0	
336	HS	Temperature Gradient	°C/min	0	30	
483	rP	Gen: Temp. Max Differential	°C	0.0	50.0	
380	AI1	Programmable Sensor #1		0	2	
777	AFC	APS Control		0	2	
805	LV	Mains Voltage	V	100	240	
2590		Burner Output	kW	10	1000	

() LPG values

BCM Parameters						
Code	Symbol	Description	Unit	Min.	Max.	Imp. Fab.
803	Srv	Enabled Services		16	27	
483	rP	Gen: Temp. Max Differential	°K	0.0	50.0	
34	HY	Burner Hysteresis	°K	5.0	20.0	
31	HL	CH#1: Minimum Set-point	°C	20.0	40.0	
39	HH	CH#1: Maximum Set-point	°C	45.0	85.0	
799	AC	Input 0/10V		0	3	
376	DI1	Programmable Input #1		0	2	
322	Po	Pump: Post-circulation	min.	1	10	
341	PL	Pump: Minimum Control	V	0	10	
313	Pr	Pump: Maximum Control	V	0	10	
792	CHP	CH: Max. Modulation	%	0	100	
611	POT	Gen: Err. Max. Parallel	°K	0	30	
612	POL	Gen: Mod. Max. Parallel	%	0	100	
650	dL	DHW: Minimum Set-point	°C	25.0	45.0	
385	dH	DHW: Maximum Set-point		50.0	65.0	
360	dt	Heater Adjustment		0	15	
656	drT	DHW: Temp. Requested Differential	°K	-20	20	
657	drH	DHW: Requested Temp. Hysteresis	°K	1	20	
310	DpT	DHW Pump: Postcirc.	sec.	5	600	
660	dbT	DHW: Temp. Maximum Boiler	°C	50.0	85.0	
48	ChSet	CH#1: Set-point	°C	20.0	85.0	
64	ChPO1	CH#1: Parallel Supply		0	1	
346	FL	Minimum Modulation	%	0	100.0	
600	mB	Burners: Min. Inserted		1	8	
616	BSt	Gen: Insertion Time	sec.	30	900	
613	BRt	Gen: Removal Time	sec.	30	900	
336	HS	Temperature Gradient	°C/min	1	30	
353	HP	CH PID: Proportional	°K	0	50	
354	HI	CH PID: Integrative	°K	0	50	
478	Hd	CH PID: Derivative	°K	0	50	
816	MI	Modbus Address		1	127	
817	MT	Modbus Time-out	sec.	0	240	
896	TU	°Fahrenheit		0	1	
309	St	Application Code		0	1	
368	VA1	Programmable Relay #1		0	1	
369	VA2	Programmable Relay #2		0	1	
771	PS	Water Pressure Sensor		0	1	
768	LG	Sens. Min. Gas Pressure		0	1	
793	COC	Chimney Obstruction Sensor		0	2	
622	FS	Minimum Flow Sensor		0	1	

3.16 - ERROR CODES

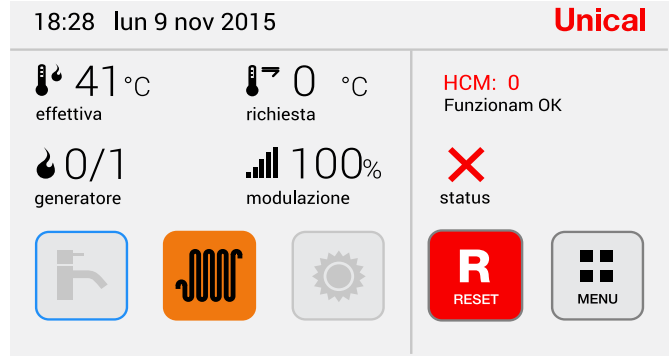
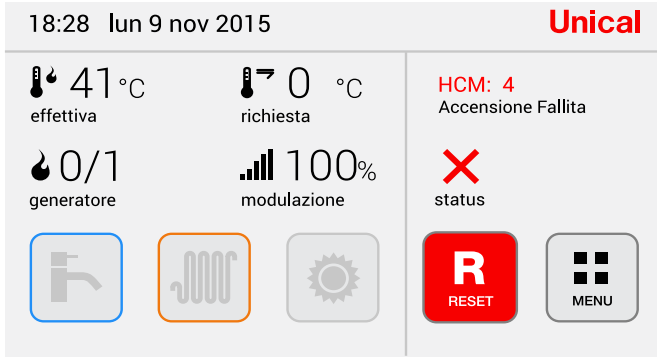

Fault that causes the boiler to stop:

- The error code is displayed, the boiler has stopped running. After solving the failure, press Reset to restart the boiler.

Fault that does NOT cause the boiler to stop:

- The error code is displayed, the boiler has a heating request, Reset icon (informing that a failure has been detected, even if the fault was temporary). Therefore, you must always carry out reset to cancel the word "Error" displayed.

(Num) = see key Par. 2.2		
CODE	DESCRIPTION detected on BMM	SOLUTIONS
01	SAFETY THERMOSTAT Triggering of the safety thermostat (10)	Press the release button on the panel and/or check that the thermostat and its connections are not blocked, and make sure the INTC switches are closed (position 1)
04	BURNER No gas or failed burner ignition	Check the gas supply or that the ignition/detection electrode is working properly (4).
05	FLAME LOSS DURING OPERATION.	Check the detection electrode
06	HIGH TEMPERATURE Boiler temperature too high	Check pump operation and if needed clean the heat exchanger (24)
10	INTERNAL FAULT	
11	Flame detection prior to ignition (parasite flame)	
12	HEATING SENSOR (11) Heating sensor fault	Check the efficiency of the sensor (see Res/Temp table) (Par.4) or its connections.
14	RETURN SENSOR (if present) Auxiliary (SRR) sensor interrupted	Check the wiring, if needed, replace the auxiliary sensor (22)
15	INSUFFICIENT WATER CIRCULATION Primary circuit water circulation insufficient ($\Delta t > 40^\circ \text{C}$)	Check pump operation and its speed - remove any obstructions in the heating system
16	HEAT EXCHANGER FREEZING (24) Heat exchanger freezing is detected. If the heating sensor detects a temperature below 2°C , burner ignition is inhibited until the sensor detects a temperature above 5°C .	Disconnect power, close the gas valve, defrost the heat exchanger carefully.

Installation instructions

22	NO AIR UPON IGNITION Stop	Check that the fan head is at least 60 Pa.
23	UNEXPECTED AIR FLOW	Blocked min pressure switch (closed)
24	SPEED OUT OF CONTROL Alteration of the fan speed; the speed is not reached.	Check fan operation (18) and the connections
26	SPEED OUT OF CONTROL Alteration of the fan speed; the speed is above that requested	Check fan operation (18) and the connections
27	NO AIR Stop	Check that the fan head is at least 60 Pa.
30	FACTORY PARAMETERS Alteration of the factory parameters or possible electromagnetic interferences.	Press the unblock key; if the anomaly persists, replace the board
32	Line voltage at 80% of the nominal value. Wait until the line voltage is > 85% of the nominal value.	Correction: if the line voltage is < 190Vac: the line voltage is really below the minimum limit, otherwise there is a monitor line error: replace BMM
CODE	DESCRIPTION detected on HCM (BCM)	SOLUTIONS
2	GAS PRESSURE MINIMUM PRESSURE SWITCH TRIGGERED stop effect	The ignition procedure is inhibited until gas pressure reaches the correct values.
17	HEAT EXCHANGER FREEZING (24) stop effect	Try to Reset since the system automatically activates an antifreeze function, therefore, it could only be a warning.
19	FLOW OVERTEMPERATURE. It is activated when the flow temperature is > 95. Resetting is automatically carried out when the temperature is < 80. Effect: Stop burner, Pump On	Circulation control
28	CLOGGED OUTLETS Stop	Check the Chimneys / Check the trap.
29	WATER IN THE COMBUSTION CHAMBER Stop	Check the combustion chamber / check the siphon.
37	PARAMETERS MEMORY DEFECTIVE Flame Block	Contact Customer Care
38	DAMAGED DEFAULT PARAMETERS due to electromagnetic interferences stop	Contact Customer Care
40	FL INTERVENTION insufficient water circulation Stop	Check water circulation
56	NO REMOTE CONTROL DETECTED Flame Block	Check electrical connections e-BUS1
57	BMM BOARD NOT DETECTED stop	check electrical connections BMM and e-BUS
58	FLOW SENSOR Stop	Connect a new sensor if the code disappears, replace the sensor otherwise check the electrical connections
93	ISPESL SAFETY DEVICES TRIGGERING Stop	check the safety devices, manually reset after releasing each individual safety device

The error codes are displayed in the info row of the remote console and remain there even if the fault is temporary. Therefore, you must always carry out a reset to cancel **the word "Alarm" displayed.**

4

INSPECTION AND MAINTENANCE



Inspections and maintenance performed professionally and according to a regular schedule, as well as the use of original spare parts, are of the utmost importance for fault-free operation of the boiler and to guarantee its long life. Yearly maintenance of the appliance is mandatory in compliance with the Laws in force.



Failure to perform Inspections and Maintenance can entail material and personal damage

4.1 - INSPECTION AND MAINTENANCE INSTRUCTIONS

To assure long-term functioning of your appliance and to avoid altering its approved status, only original **UNICAL** spare parts must be used.

If a component needs to be replaced:

- Disconnect the appliance from the electrical mains and make sure that it cannot be reconnected accidentally.
- Close the gas shut-off valve upstream of the boiler.
- If needed, and depending on the intervention to be carried out, close any shut-off valves on the flow and return line of the heating system, as well as the cold water inlet valve.

Once all maintenance operations are complete resume boiler operation

- Open the heating flow and return pipes, as well as the cold water inlet valve (if closed previously).
- Vent and, if necessary, restore the heating pressure until reaching a pressure of 0.8/1.0 bar.
- Open the gas shut-off valve.
- Switch the boiler on
- Make sure the appliance is gas tight and watertight.



OBLIGATION!
wear protective gloves



Danger of burns!
Caution during maintenance operations.

TABLE OF THE RESISTANCE VALUES ACCORDING TO THE TEMPERATURE, HEATING SENSOR (SR) AND DHW SENSOR (SS) AND HEATING RETURN SENSOR, IF ANY (SRR)

T°C	0	1	2	3	4	5	6	7	8	9
0	32755	31137	29607	28161	26795	25502	24278	23121	22025	20987
10	20003	19072	18189	17351	16557	15803	15088	14410	13765	13153
20	12571	12019	11493	10994	10519	10067	9636	9227	8837	8466
30	8112	7775	7454	7147	6855	6577	6311	6057	5815	5584
40	5363	5152	4951	4758	4574	4398	4230	4069	3915	3768
50	3627	3491	3362	3238	3119	3006	2897	2792	2692	2596
60	2504	2415	2330	2249	2171	2096	2023	1954	1888	1824
70	1762	1703	1646	1592	1539	1488	1440	1393	1348	1304
80	1263	1222	1183	1146	1110	1075	1042	1010	979	949
90	920	892	865	839	814	790	766	744	722	701

Relation between the temperature (°C) and the nom. resistance (Ohm) of the heating sensor SR and of the domestic hot water sensor SS

Example: At 25°C, the nominal resistance is 10067 Ohm At 90°C, the nominal resistance is 920 Ohm



We recommend having qualified technical personnel carry out the provisions of current regulation concerning periodic maintenance checks.

Since the dust is vacuumed inside, the flue gas side resistance, through the boiler, increases which, eventually, will lead to a reduction of the thermal load (and, consequently, of the power). Before cleaning, check the thermal load (see 3.13) and the CO₂ percentage (see 3.13). If the read load (with correct CO₂) is around 5% of the indicated value, the boiler does not need to be cleaned.

Therefore, the operation can be limited to cleaning the siphon



ATTENTION!

A drop in thermal load may be caused by the obstruction of the exhaust duct or of the air inlet duct. Firstly check that this is not the cause.

If a load reduction is detected of more than 5%, check the cleanliness of the condensate collection pan and of the burner. Clean the siphon also.

First phase – Disassembly

- Close the power and gas supply **ensuring that the valve is closed properly.**
- Remove:
 - all casings



- Turn the indicated screw to lift the cover



- Remove the 2 cover fastening screws

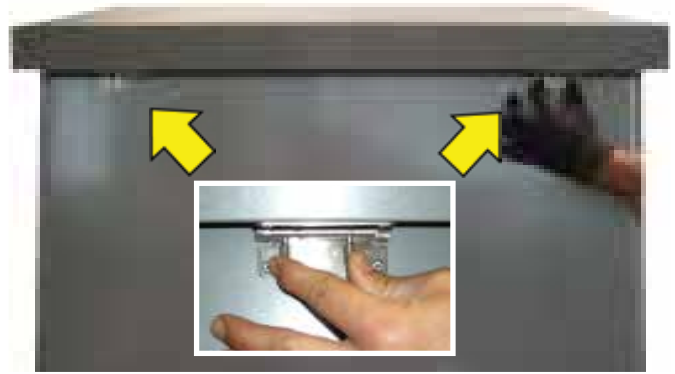

- Act on the two rear closing hinges to remove the cover



- Remove the casing fastening screws, rear, front and lateral.



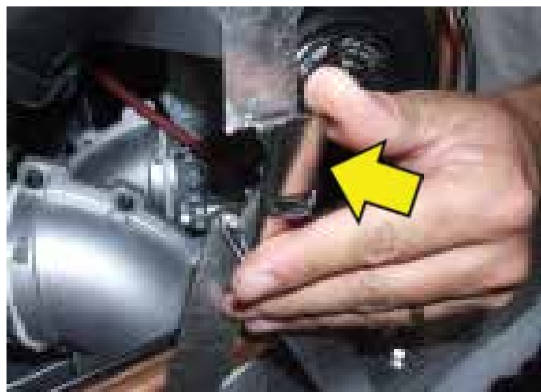

- Release the fan chamber fastening spring (right/left side).



- Remove the red silicon pipes and then the fan chamber

• Element screws

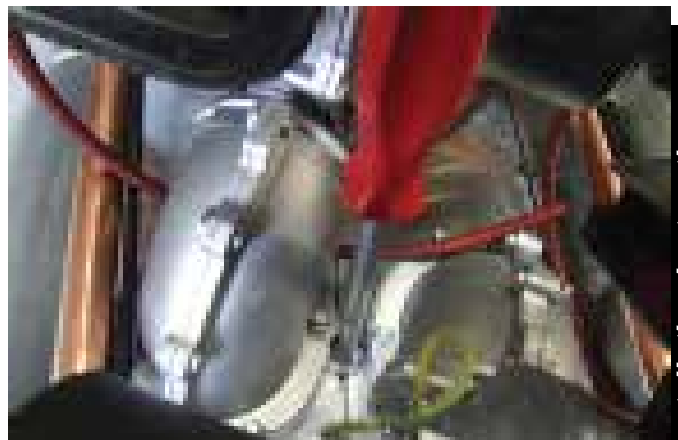
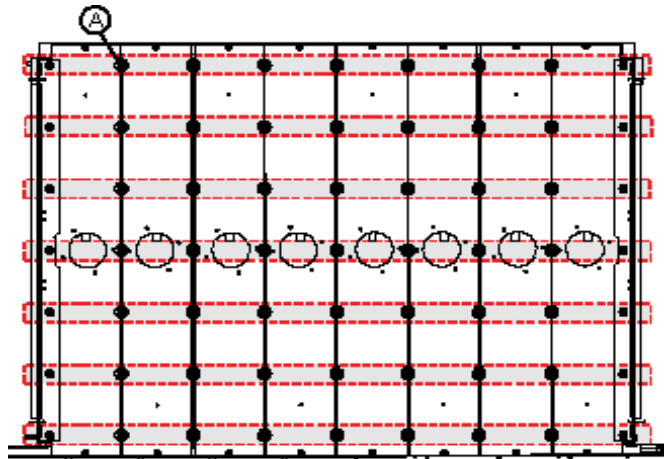

Installation instructions



- Remove screws "A" for each element (with socket wrench and 13 mm flat spanner)

• Element screws

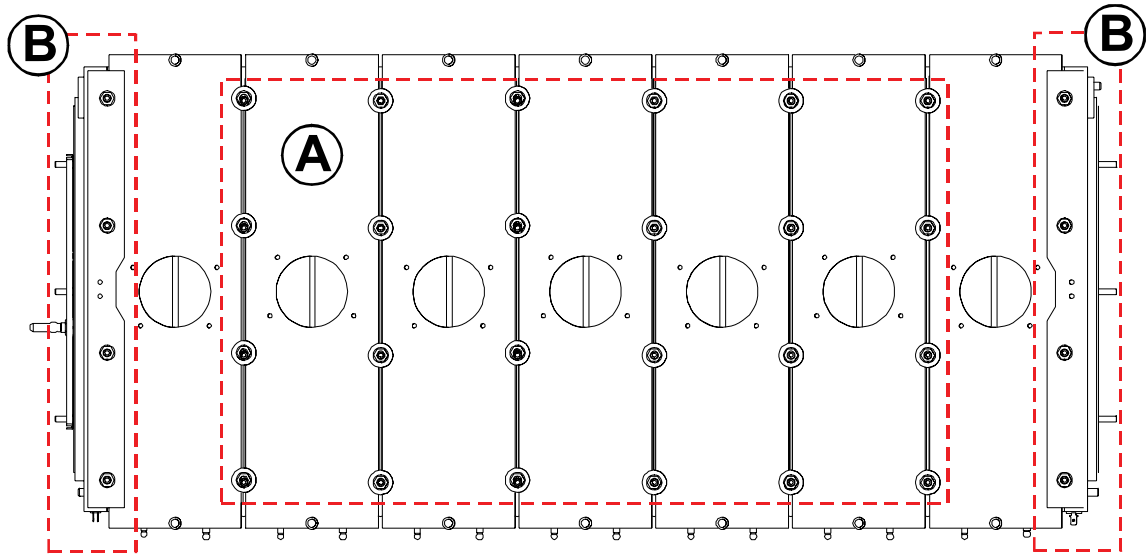

- Remove screws "A" for each element (with 13 mm socket wrench)

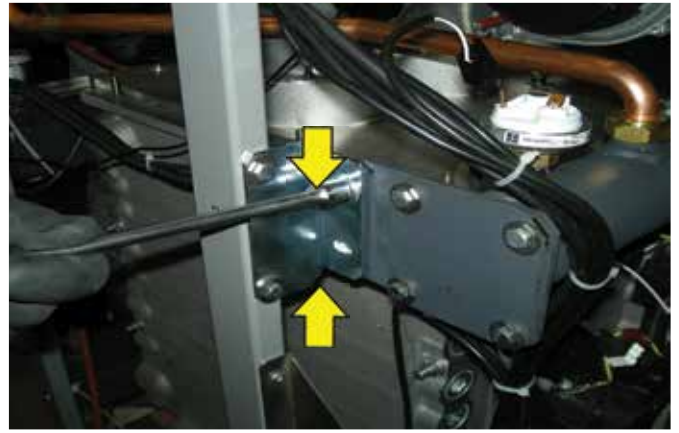

- Remove the gas pipe fastening screws (right and left sides)

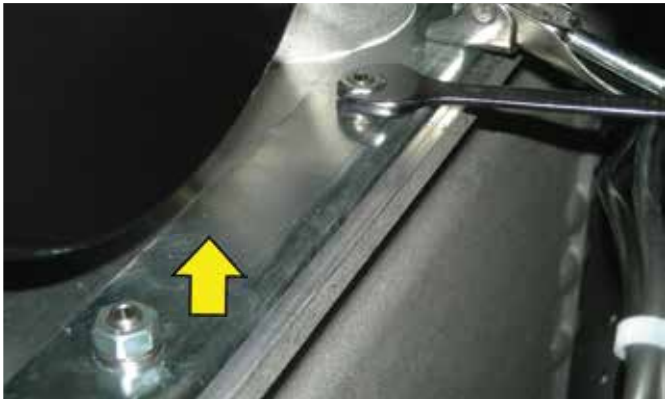

- Remove the screws "B" (with 13 mm socket wrench / 13 mm hex spanner) and remove the fastening plates



- Remove the four screws with a 10 mm socket wrench, then the gas flange



- Lift the burner block (front part)

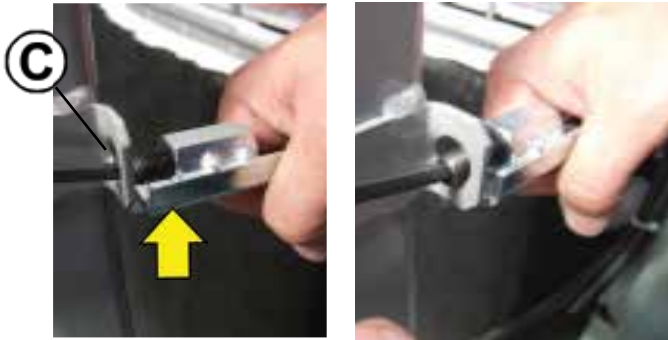

- Slightly lift the rear burner **block** and remove the 2 pins using a 5 mm hex spanner, until you reach the holes "C" (left and right side).



Installation instructions



- Remove the gas fittings from the gas manifold using the 36 mm flat spanner.

Second phase – Cleaning

- Remove the gaskets and the burners.
- Dry clean the burners by blowing compressed air from the “flame side”
- Visually inspect the welding on the corner pieces and on the burner mesh.



The burner gaskets must be replaced at each cleaning operation.

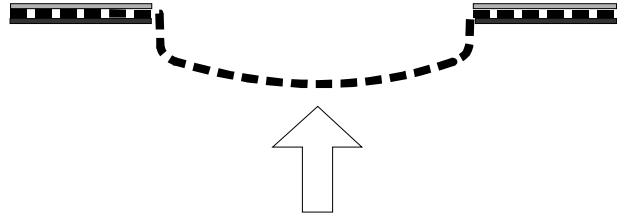

- Wash the combustion chamber with water, taking care not to wet the electrical wiring.
During this operation, make sure that the condensate drain pipe always remains clear so that the washing water does not leak from the inspection opening.
- Blow the combustion chamber with compressed air, trying to remove any dirt still attached to the pins.
- When the parts have been washed, make sure that the condensate drain trap is clear: clean it if necessary
- Inspect the flue gas exhaust pipe and the flue

Third phase – Re-assembly

- After cleaning the body and/or burners, put the burners back in their seats
- Position the **new graphite gaskets**



When reassembling, proceed in reverse order, taking care to tighten the fastening screws of the mixer/fan unit to the body, with 13 Nm tightening torque



**ATTENTION
AT EACH MAINTENANCE OPERATION, IT IS MANDATORY TO REPLACE THE SEALING GASKETS OF EACH BURNER.**

- Before ignition, check that the condensation drain trap is properly filled with water.
- Before opening the gas supply valve again make sure that the previously loosened gas fitting, is tight. To do this, open the valve and check its seal with soapy solution.
- As a burner ignites, immediately check the seals between each individual gas valve and its premixing chamber
- Analyse the combustion and check its parameters.
- Make sure that all opened gas pressure sockets are closed.

PAGE LEFT INTENTIONALLY BLANK

4.2 - PRACTICAL CONNECTION WIRING DIAGRAM

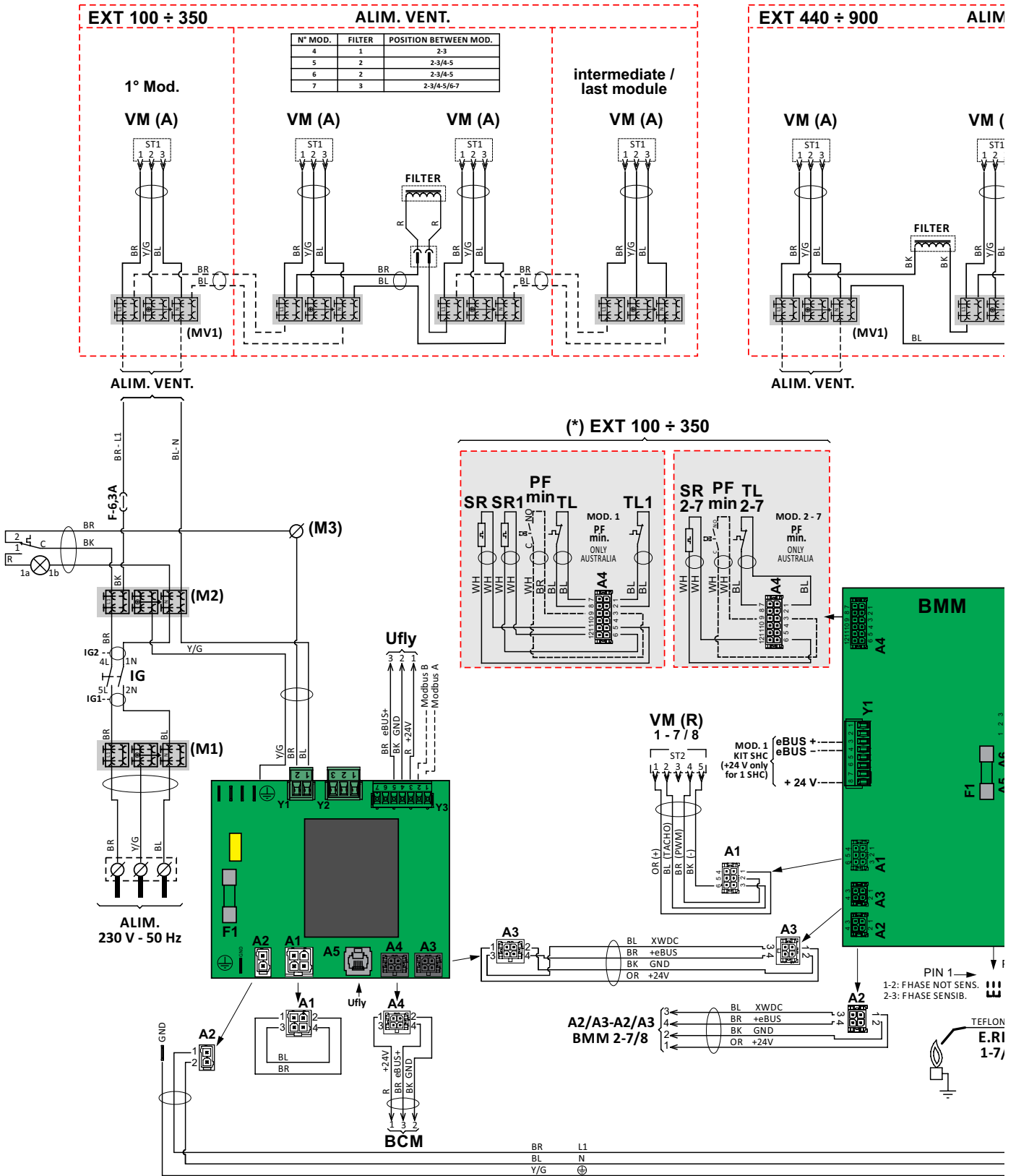

KEY	
E. ACC.	Ignition electrode
E. RIL.	Detection electrode
HSCP / Ufly	Temperature control
SR	Heating sensor (only mod.1)
SR 1...7	Local heating sensor
PF	Flue gas press. switch (only mod.1)
PF min	Flue gas minimum press. switch (only mod.1)
SL	Condensate level sensor (mod.2)

T. ACC	Ignition transformation
TL	Limit thermostat
TL 1....7	Local limit thermostat
VG	Gas valve
VM (A)	Modulating Fan Power Supply
VM (R)	Modulating Fan Det./Adjustment
SRR	Global return sensor
PG	Gas pressure switch
IG	Main switch

ALIM. VENT.

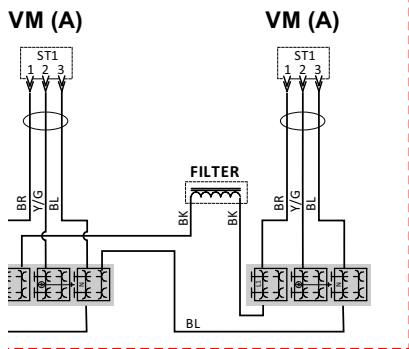

COLOURS	
BL	BLUE
BR	BROWN
BK	BLACK
G	GREEN
GR	GREY
L BL	SKY BLUE
OR	ORANGE
PK	PINK
R	RED
Y	YELLOW
YG	YELLOW GREEN
WH	WHITE
VI	VIOLET

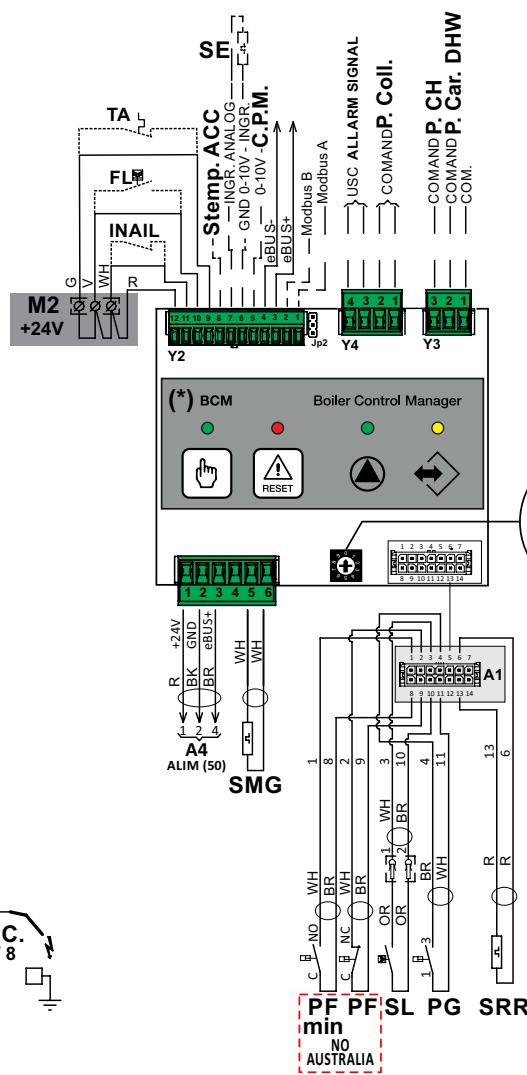
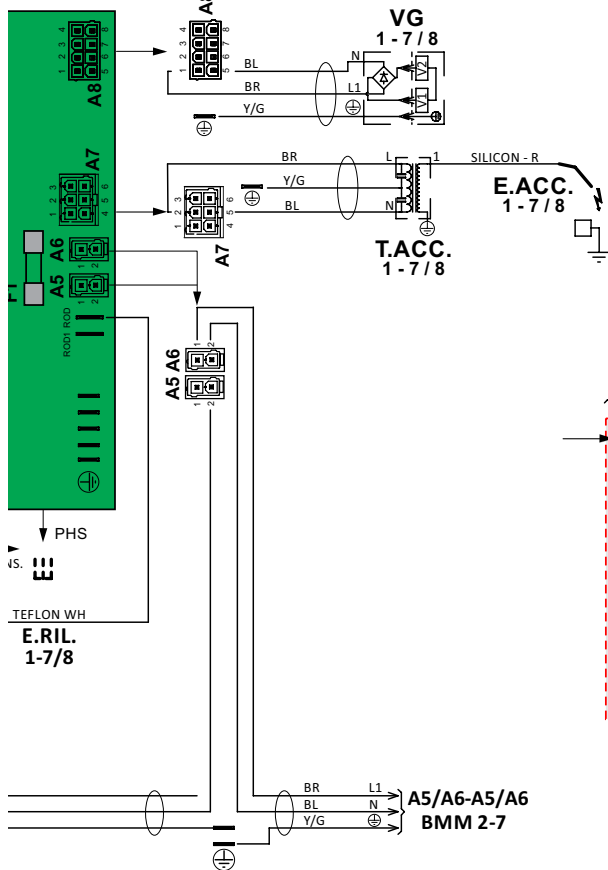

(*) EXT 440 ÷ 900

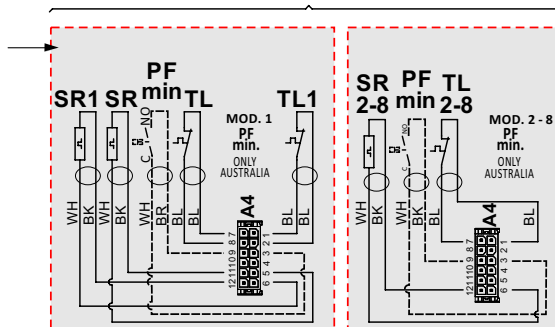

Installation instructions

TLG	Main limit thermostat
LTLG	Main limit thermostat lamp
F	Fuse
BCM (*) the connections reported below are only meant as an indication and are to be carried out on the services return terminal boards "B" indicated in chap. 3.10.	
SMG	Global flow sensor
S.temp ACC	Storage tank temperature sensor
SE	External temperature sensor

ANALOG INPUT	Analogue input
GND 0-10V ING	Analogue input 0-10 V
0-10V C.P.M.	Modulating Pump Control
ALARM SIGNAL	Alarm Output
Comm P. COLL	Boiler manifold pump control
Comm P. CH	Heating pump control
P. car DHW	Storage tank loading pump control
COM.	Common

Unical[®]



www.unical.eu

TRANSLATION OF ORIGINAL INSTRUCTIONS - 00338303EN - 1st ed. 01/19

Unical AG S.p.A. 46033 Casteldario - Mantua - Italy - tel. +39 0376 57001 - fax +39 0376 660556
info@unical-ag.com - export@unical-ag.com - www.unical.eu

Unical shall not be held liable for any inaccuracies due to transcription or printing errors.
Furthermore, it reserves the right to modify its products as deemed necessary or useful, without affecting their essential features.