

Unical[®]

XC-K

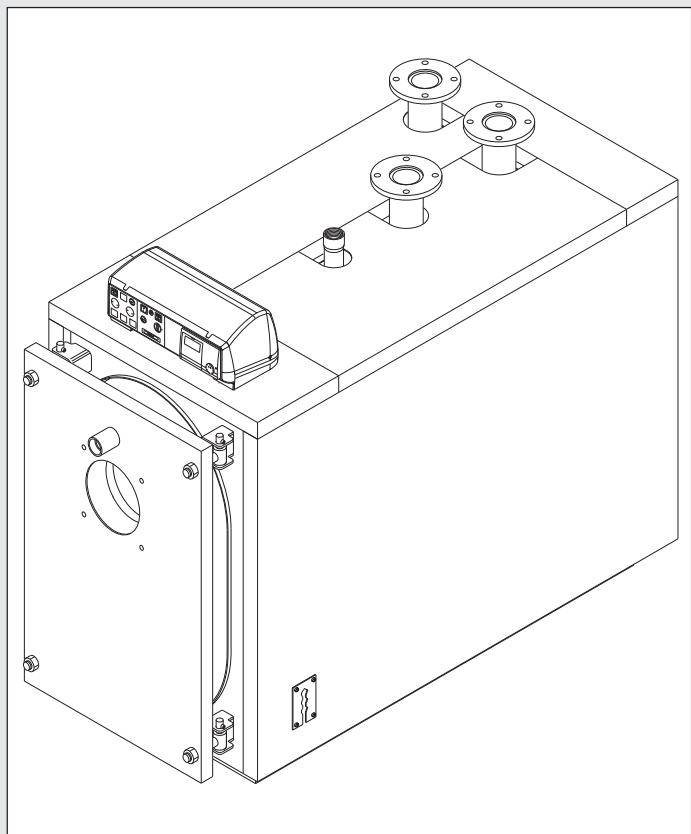

INSTALLATION AND MAINTENANCE INSTRUCTIONS

General information

TABLE OF CONTENTS

1 GENERAL INFORMATION	3
1.1 Symbols used in the manual	3
1.2 Appropriate use of appliance	3
1.3 Water treatment	3
1.4 Information for user or system manager	3
1.5 Safety warnings	4
1.6 Technical data plate	5
1.7 General warnings	6
2 TECHNICAL FEATURES AND DIMENSIONS	7
2.1 Technical features	7
2.2 Main components	7
2.3 Dimensions	8
2.4 Operating data	11
3 INSTALLATION INSTRUCTIONS	12
3.1 General warnings	12
3.2 Installation standards	13
3.3 Handling	14
3.4 Positioning in boiler room	14
3.5 Burner	14
3.5.1 - Choosing the burner	14
3.5.1 Installing the burner	15
3.6 Connecting flame sight glass to burner	15
3.7 Furnace door adjustment, opening and closing	16
3.7.1 XC-K 124÷XC-K 900 boilers	16
3.7.2 XC-K 1140÷XC-K 1420 boilers	19
3.7.3 XC-K 1820÷XC-K 2160 boilers	17
3.7.4 Important note	17
3.8 Connecting flue exhaust pipe	18
3.9 Condensation drainage	18
3.10 Connecting boiler to system	19
3.11 Filling the system	19
3.12 Connecting gas	20
3.13 Packaging	21
3.14 Assembling casing	22
3.15 Electrical connections	24
3.16 MODULATING MASTER panel board code 37892	26
3.17 Programming heating controllers with single boiler	26
3.18 Hydraulic and electric system connection with panel board code 37892	30
3.19 Programming heating controllers with boilers in cascade	32
3.20 MODULATING CASCADE panel board code 37900	36
3.21 Hydraulic and electric system connection with boilers in cascade panel board code 37892 and 37900	38
3.22 DUAL-STAGE MASTER panel board code 38778	40
3.23 Programming heating controllers with single boiler	40
3.24 Hydraulic and electric system connection with panel board code 38778	44
3.25 Programming heating controllers with boilers in cascade	46
3.26 DUAL-STAGE CASCADE panel board code 37901	50
3.27 Hydraulic and electric system connection with boilers in cascade panel board code 38778 and 37901	52
3.28 Commissioning	54
3.29 Adjusting the burner	55
4 INSPECTIONS AND MAINTENANCE	55
Inspection and maintenance instructions	55
Boiler body maintenance	56
Maintenance of burner	56
Checking ignition electrode	56
Components to check during yearly inspection	56

Attention: this manual contains instructions for the exclusive use of the professionally qualified installer and/or maintenance technician in compliance with current legislation.

The user is **NOT** qualified to intervene on the boiler.

The manufacturer will not be held liable in case of damage to persons, animals or objects resulting from failure to comply with the instructions contained in the manuals supplied with the boiler.

1 GENERAL INFORMATION

1.1 - SYMBOLS USED IN THE MANUAL

Pay special attention when reading this manual to the parts marked by the symbols:



DANGER!
Serious danger for personal safety and life



ATTENTION!
Possible hazardous situation for the product and the environment



NOTE!
Suggestions for the user

1.2 - APPROPRIATE USE OF APPLIANCE



The XC-K appliance has been built according to the current level of engineering and acknowledged technical safety rules.

Nonetheless, if improperly used, dangers could arise for the safety and the very life of the user and other persons or damage to the equipment or other objects.

The appliance is intended to operate in hot air circulation heating systems.

Any other use must be considered improper.

UNICAL shall not be held liable for any damage resulting from improper use; in this case the user is fully responsible for the risk.

Use according to the intended purposes also include careful compliance with the instructions in this manual.

1.3 - WATER TREATMENT (see specific booklet)



- The hardness of the feed water conditions the frequency at which the domestic hot water exchanger must be cleaned.
- If the water has a hardness greater than 15°f, we recommend using water softeners, chosen according to the characteristics of the water.
- We recommend checking and cleaning the domestic hot water exchanger at the end of the first year of use and every two years thereafter; on this occasion, also check the state of wear of the anode.

1.4 - INFORMATION FOR SYSTEM MANAGER



- The user must be instructed concerning the use and operation of his heating system, in particular:
- Deliver these instructions to the user, as well as other documents concerning the appliance inserted in the bag contained in the packaging. **The user must keep this documentation so that it is available for further consultation.**
- Inform the user about the importance of the air vents and the flue gas exhaust system, highlighting their essential features and the absolute prohibition of modifying them.
- Inform the user concerning controlling the system's water pressure as well as operations to restore it.
- Inform the user concerning correct temperature control, control units/thermostats and radiators for saving energy.
- Remember that the system must receive regular maintenance at least once a year and a combustion analysis must be performed in the timetable foreseen by standards in force.
- Should the appliance be sold or transferred to a new owner or if you move and leave the appliance, always make sure that the instruction booklet accompanies it in order to be consulted by the new owner and/or installer.

General Information

1.5 - SAFETY WARNINGS



Attention!

The appliance must be installed, adjusted and maintained by professionally qualified personnel, in compliance with standards and provisions in force. Incorrect installation can cause damage to persons, animals and objects for which the manufacturer cannot be held responsible.



DANGER!

NEVER attempt performing maintenance or repairs on the boiler on your own initiative.

Any work must be done by professionally qualified personnel.

We recommend stipulating a maintenance contract.

Insufficient or irregular maintenance can jeopardise the operating safety of the appliance and cause damage to persons, animals and objects for which the manufacturer cannot be held responsible.



Modifying parts connected to appliance

Do not modify the following parts:

- the boiler
- the gas, air, water and electricity lines
- flue gas pipe, safety valves and heating water drain pipe
- construction parts which affect the operating safety of the appliance



Attention!

To tighten or loosen the screwed fittings, use only appropriate fixed spanners.

Incompliant use and/or inappropriate tools can cause damage (e.g. water or gas leakage).



ATTENTION!

Indications for propane gas-fired appliances

Make sure that the gas tank has been deaerated before installing the appliance.

For state-of-the-art deaeration of the tank, contact the LPG supplier or a person qualified in compliance with law.

If the tank has not been professionally deaerated, ignition problems could arise.

In that case, contact the supplier of the LPG tank.



Smell of gas

Should a smell of gas be perceived, follow these safety guidelines:

- do not turn electric switches on or off
- do not smoke
- do not use the telephone
- close the gas shut-off valve
- air out the area where the gas leakage has occurred
- inform the gas supplier or a company specialised in installation and maintenance of heating systems.



Explosive and easily flammable substances

Do not use or store explosive or easily flammable materials (e.g. petrol, paints, paper) in the room where the appliance is installed.

1.6 - TECHNICAL DATA PLATE

The technical data plate is adhesive and is included in the document case; it must be applied by the installer on the outside of the casing.

The serial number of the boiler is on the riveted plaque on the front plate of the body (front right bottom side).

CE marking

The CE markings certifies that the boilers meet:

- The essential requirements of the gas appliance directive (90/396/EEC)
- The essential requirements of the electromagnetic compatibility directive (89/336/EEC)
- The essential requirements of the efficiency directive (92/42/EEC)

Condensing boiler		Boiler water content	
Serial No.	*	Max. Water pressure	bar
Year of construction		Max. Water temperature	°C

Fuels Gas Category Diesel oil

OUTPUTS	kW (80°C - 60°C)	kW (50°C - 30°C)
Useful gas output		
Useful diesel output		
Furnace		

P.I. No. CE

Approvals

* For serial No. see boiler body

Unical[®] AG S.P.A. 46033 CASTELDARIO (MN) - Via Roma
 tel. 0376 57001 - fax 0376 660556
 www.unical.eu info@unical-ag.com

ATTENTION

Wherever the boiler operates with an air-blown gas-fired burner, the appliance, not belonging to any category among those considered in Annex II of the Legislative Decree 93 of 25/02/2000 (Implementation of the Directive 97/23/EC regarding pressurised equipment), and moreover being considered by the Directive 90/396/EEC (Gas-fired appliances - transposed in Italy with DPR 661 of 15/11/1996) to which art. 1 comma 3 paragraph "f.5" refers, is excluded from the range of application of the decree itself.

1.7 - GENERAL WARNINGS

The instruction booklet is an integral and essential part of the product and must be kept by the user or system manager.

Read the warnings contained in this instruction booklet carefully as they provide important guidelines regarding installation, use and maintenance safety.

Keep the booklet with care for further consultation.

Installation and maintenance must be performed in compliance with standards in force according to the instructions of the manufacturer and by qualified and certified personnel in compliance with law.

By professionally qualified personnel we mean: personnel with specific technical skill in the field of heating system components for civil use, domestic hot water production and maintenance. Personnel must have the qualifications foreseen by current legislation.

Incorrect installation or improper maintenance can cause damage to persons, animals or objects for which the manufacturer is not responsible.

Before performing any cleaning or maintenance, disconnect the appliance from the energy mains by acting on the switch of the system and/or through the specific cut-off devices.

Not obstruct the terminals of the intake/exhaust ducts.

In case of failure and/or malfunctioning of the appliance, switch it off and do not try to repair it or intervene on it directly. Contact only personnel qualified in compliance with law.

Any repairs must be performed solely by personnel authorised by Unical using original spare parts only. Failure to comply with the above can jeopardise the safety of the appliance.

To guarantee appliance efficiency and its correct operation, yearly maintenance must be performed by qualified personnel.

Should you decide not to use the appliance, parts entailing potential sources of hazard must be made safe.

Should the appliance be sold or transferred to a new owner or if you move and leave the appliance, always make sure that the instruction booklet accompanies it in order to be consulted by the new owner and/or installer.

Only original accessories must be used for all appliances with optionals or kits (including electric).

This appliance is intended solely for the use for which it was expressly designed. Any other use is to be considered improper and therefore dangerous.

2

TECHNICAL FEATURES AND DIMENSIONS

2.1 - TECHNICAL FEATURES

The XC-K boilers are made up of an external shell which houses the completely wet blind cylindrical furnace, where the first two combustion gas passes are completed, and by a special tube and shell, used for the third pass.

The tube and shell, placed horizontally in the lower part of the body, is composed of stainless steel 316L tubes and aluminium fins.

The guided path of the combustion gas exploits the thermal exchange surfaces to a maximum and evenly balances strains on the materials.

The construction fully complies with prescriptions laid down in EN 303 part 1.

The components of the pressurised part, such as sheets and tubes, are made in certified carbon steel, according to the EURONORM 25 and EURONORM 28 tables.

Welding devices and procedures are approved by TÜV (D) - UDT (PL) - SA (S) and ISPESL (I).

The boilers are equipped with an opening door on the right or left. The outer shell is covered with a glass wool insulation 100 mm thick, in turn protected by a mineral fibre fabric.

The top part of the shell is provided with hooks for lifting the boiler.

Note: XC-K boilers are designed to operate with ON/OFF, dual stage or modulating burner, as long as the minimum heat output that can be reached is no lower than the value indicated on the technical data plate.

The boilers are provided with two ½" attachments for conduits with an inside diameter of 15 mm (suitable to house 3 bulbs

each).

The shell has holes at the sides for the cable glands of the power, pumps, burner cables and those of any other auxiliary device.

2.2 - MAIN COMPONENTS

XC-K boilers are equipped with a blind cylindrical furnace, in which the central flame of the burner is reversed peripherally towards the front part. When the combustion gases have reached the front part, they are sent through the door into the tubes of the third pass to reach the rear flue gas chamber and then the chimney.

The combustion chamber is always pressurised while the burner is operating, within the power range of the boiler.

For the value of this pressure, see the tables on pages 8÷10, in the column "Flue gas side pressure drops".

The chimney must be calculated so that no positive pressure is detected at its base.

- 1 Furnace
- 2 Smoke pipes with smoke diverters
- 3 Door with flame sight glass
- 4 Smoke chamber
- 5 Body insulation
- 6 Panel board
- M Flow
- Rbt Low temperature return
- Rat High temperature return

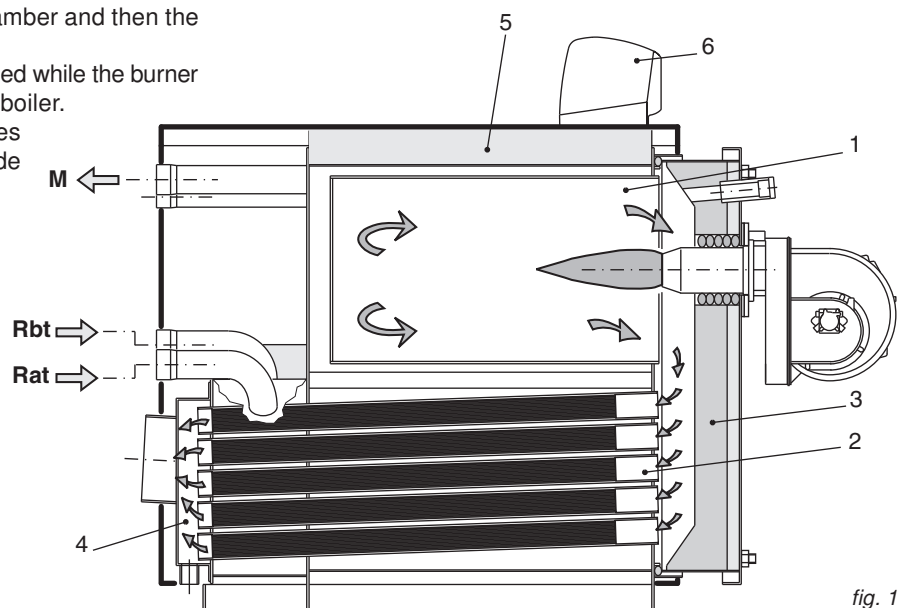

fig. 1

Technical features and dimensions

2.3 - DIMENSIONS XC-K 124

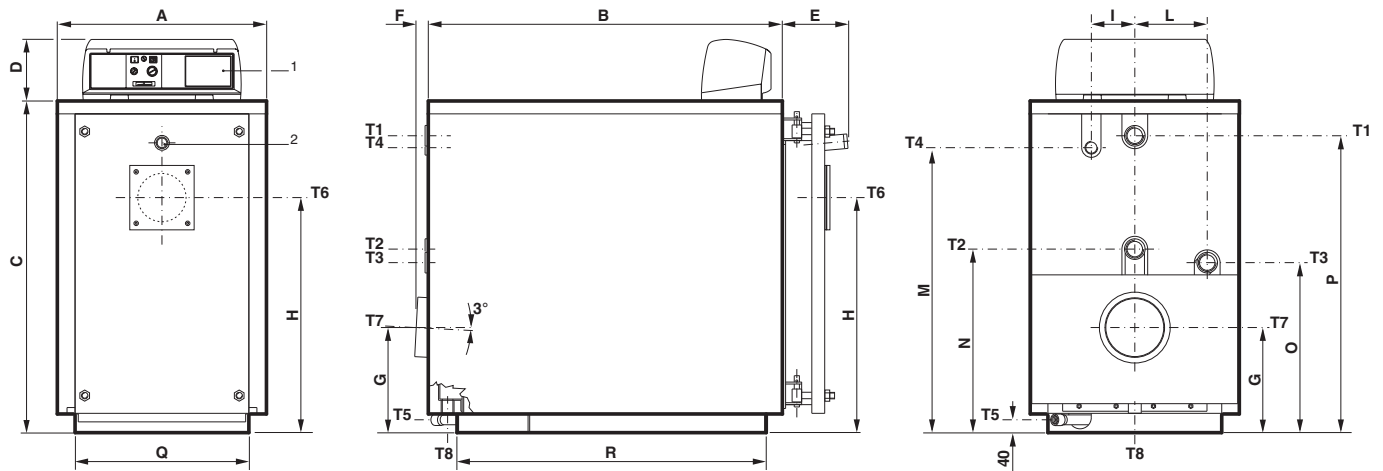

fig. 2

- 1 Panel board
- 2 Flame sight glass
- T1 C.H. flow
- T2 Low temperature C.H. return

- T3 High temperature C.H. return
- T4 Expansion vessel connection
- T5 Boiler drain
- T6 Burner connection

- T7 Chimney connection
- T8 Condensation drain

XC-K	Nominal output (80°-60°C)	Nominal output (50°-30°C)	Nominal input	Boiler capacity	Pressure drop water side(**)	Pressure drop flue side	Maximum operating pressure boiler	Weight	CONNECTIONS						
									T1	T2	T3	T4	T5	T6	T7
Model	kW	kW	kW	l	kPa	daPa	bar	kg	ISO 7/1	ISO 7/1	ISO 7/1	ISO 7/1	mm	mm	mm
124	112,8	124	115,9	140	1,5	9,8	6	365	Rp 2	Rp 2	Rp 1¼	Rp ¾	150	182	40

XC-K	DIMENSIONS															
	A	B	C	D	E	F	G	H	I	L	M	N	O	P	Q*	R*
Model	mm	mm	mm	mm	mm	mm	mm	mm	mm	mm	mm	mm	mm	mm	mm	mm
124	650	1100	1032	190	205	37	329	730	135	225	885	570	528	922	540	961

(*) Minimum dimensions for boiler room access.

(**) Pressure drops corresponding to a thermal drop of 15K.

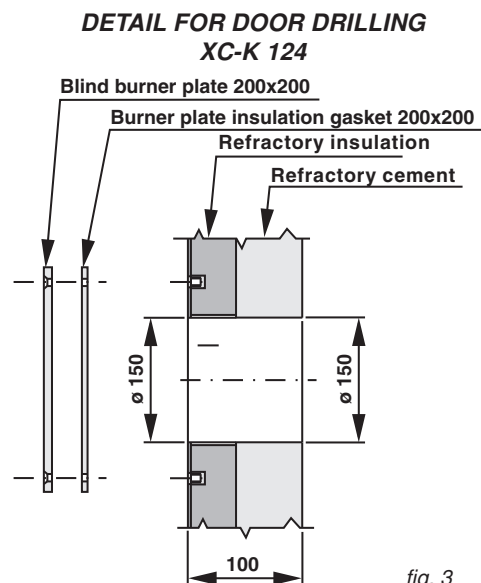

fig. 3

Technical features and dimensions

XC-K 200÷570

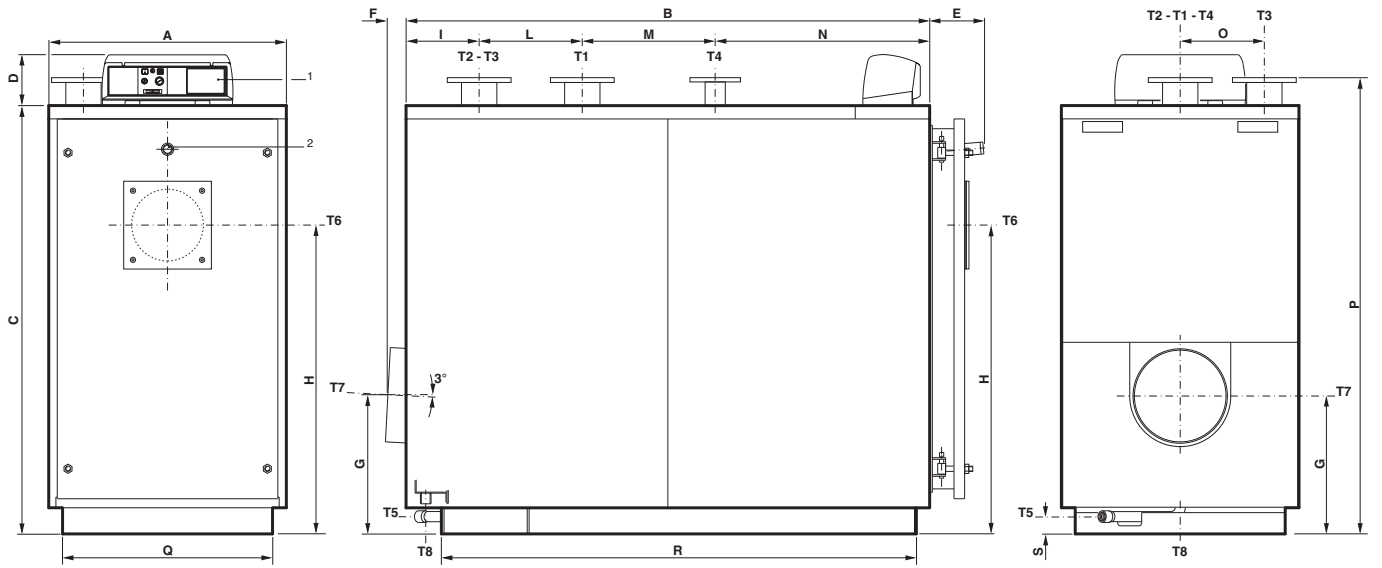

fig. 4

- 1 Panel board
- 2 Flame sight glass
- T1 C.H. flow
- T2 Low temperature C.H. return

- T3 High temperature C.H. return
- T4 Expansion vessel connection
- T5 Boiler drain
- T6 Burner connection

- T7 Chimney connection
- T8 Condensation drain

XC-K Model	Nominal output (80°-60°C) kW	Nominal output (50°-30°C) kW	Nominal input kW	Boiler capacity l	Pressure drop water side(**) kPa	Pressure drop flue side daPa	Maximum operating pressure boiler bar	Weight kg	CONNECTIONS							
									T1 UNI 2276 PN6	T2 UNI 2276 PN6	T3 UNI 2276 PN6	T4 ISO 7/1	T5 ISO 7/1	T6 Ø mm	T7 Øi mm	T8 Øe mm
200	182,7	200	186,9	260	3,8	18,6	6	525	DN 65	DN 65	DN 65	Rp 1½	Rp ¼	180	202	40
290	265,6	290	271	305	2,5	25,4	6	660	DN 80	DN 80	DN 80	Rp 2	Rp 1	180	252	40
400	367,1	400	373,8	332	3,2	32,3	6	800	DN 80	DN 80	DN 80	Rp 2	Rp 1	180	252	40
480	440,7	480	448,6	544	2	34,3	6	1007	DN 100	DN 100	DN 100	Rp 2	Rp 1	220	302	40
570	523,3	570	532,7	515	2,9	39,2	6	1137	DN 100	DN 100	DN 100	Rp 2	Rp 1	220	302	40

XC-K Model	DIMENSIONS																
	A mm	B mm	C mm	D mm	E mm	F mm	G mm	H mm	I mm	L mm	M mm	N mm	O mm	P* mm	Q* mm	R* mm	S mm
200	720	1450	1132	190	205	48	374	790	255	320	250	625	255	1248	610	1311	45
290	790	1465	1282	190	235	55	402	900	231	359	250	625	275	1385	680	1314	60
400	790	1755	1282	190	235	65	402	900	271	379	450	655	275	1385	680	1614	60
480	854	1770	1472	190	270	67	494	1062	306	358	500	606	306	1585	750	1606	65
570	854	1940	1472	190	270	67	490	1062	306	358	500	776	306	1585	750	1776	65

(*) Minimum dimensions for boiler room access.

(**) Pressure drops corresponding to a thermal drop of 15K.

DETAIL FOR DOOR DRILLING XC-K 200

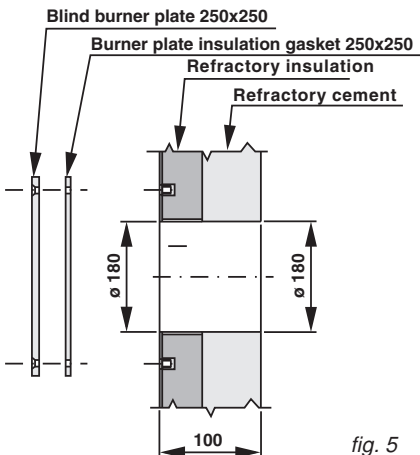

fig. 5

DETAIL FOR DOOR DRILLING XC-K 290÷400

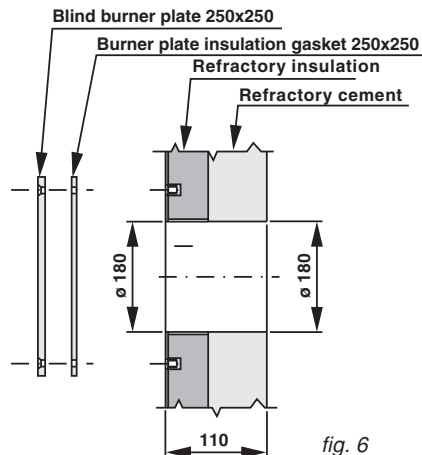

fig. 6

DETAIL FOR DOOR DRILLING XC-K 480÷570

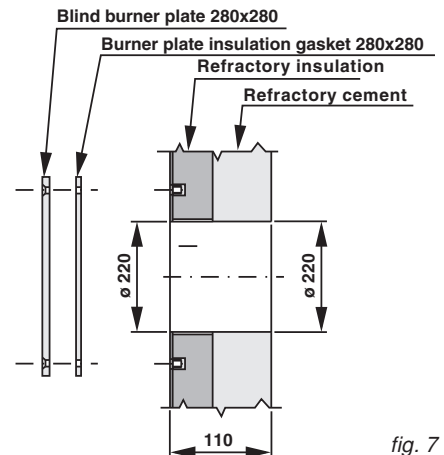

fig. 7

Technical features and dimensions

XC-K 700÷2160

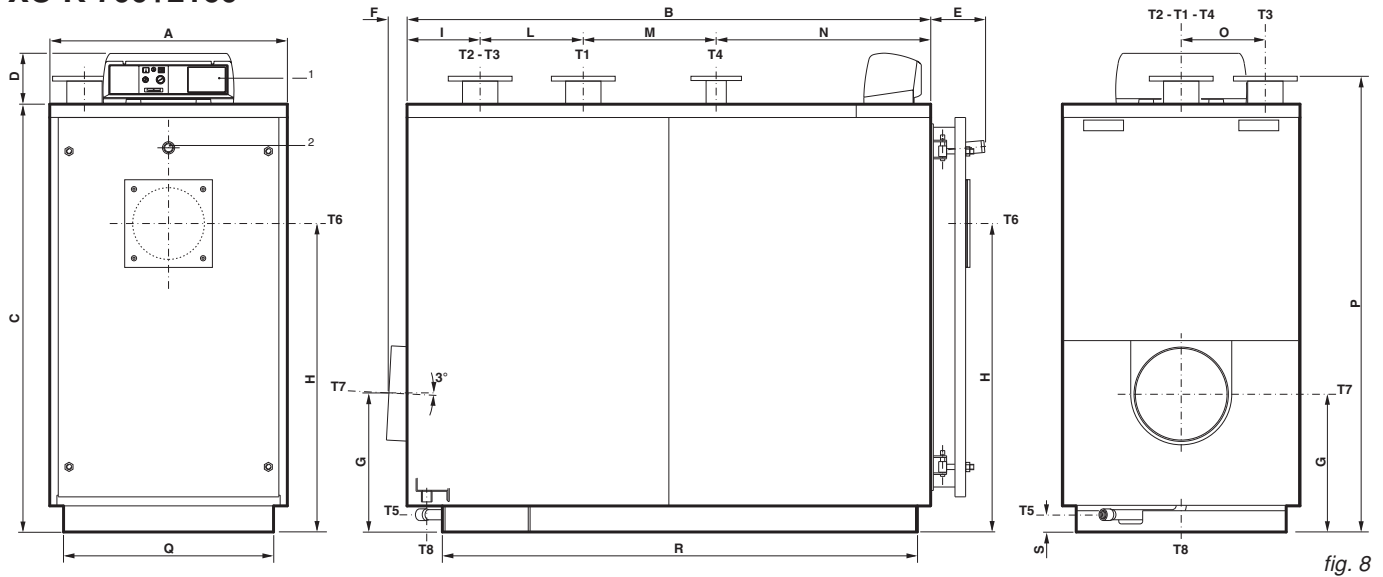

fig. 8

- 1 Panel board
- 2 Flame sight glass
- T1 C.H. flow
- T2 Low temperature C.H. return

- T3 High temperature C.H. return
- T4 Expansion vessel connection
- T5 Boiler drain
- T6 Burner connection

- T7 Chimney connection
- T8 Condensation drain

XC-K	Nominal output (80°-60°C)	Nominal output (50°-30°C)	Nominal input	Boiler capacity	Pressure drop water side(**)	Pressure drop flue side	Maximum operating pressure boiler	Weight	CONNECTIONS						
									T1	T2	T3	T4	T5	T6	T7
Model	kW	kW	kW	l	kPa	daPa	bar	kg	UNI 2276 PN6	UNI 2276 PN6	UNI 2276 PN6	ISO 7/1	Ø mm	Øi mm	Øe mm
700	642,6	700	654,2	625	3	46	6	1376	DN 125	DN 125	DN 65	Rp 1	270	352	40
900	826,2	900	841,1	664	3,7	58,8	6	1613	DN 125	DN 125	DN 65	Rp 1	270	352	40
1140	1046,6	1140	1065,4	1107	3,5	73,5	6	2158	DN 150	DN 150	DN 80	Rp 1½	320	402	40
1420	1303,6	1420	1327,1	1157	4	88,2	6	2443	DN 150	DN 150	DN 80	Rp 1½	320	402	40
1820	1670,8	1820	1700,9	1936	3,9	90,2	6	3458	DN 200	DN 200	DN 100	Rp 1½	320	452	40
2160	1983	2160	2018,7	1904	5,5	98	6	3765	DN 200	DN 200	DN 100	Rp 1½	320	452	40

XC-K		DIMENSIONS															
Modello	A	B	C	D	E	F	G	H	I	L	M	N	O	P*	Q*	R*	S
700	894	1970	1612	190	292	65	523	1161	275	388	500	807	316	1715	790	1787	65
900	894	2340	1612	190	292	65	523	1161	405	388	500	1047	316	1715	790	2157	65
1140	1064	2360	1802	190	317	57	551	1287	289	624	900	547	390	1911	960	2157	55
1420	1064	2740	1802	190	317	57	552	1287	459	624	900	757	390	1911	960	2537	55
1820	1204	2980	2052	190	387	53	681	1493	372	563	785	1260	432	2165	1100	2752	95
2160	1204	3204	2052	190	387	54	681	1493	371	563	1010	1260	432	2165	1100	2977	95

(*) Minimum dimensions for boiler room access.

(**) Pressure drops corresponding to a thermal drop of 15K.

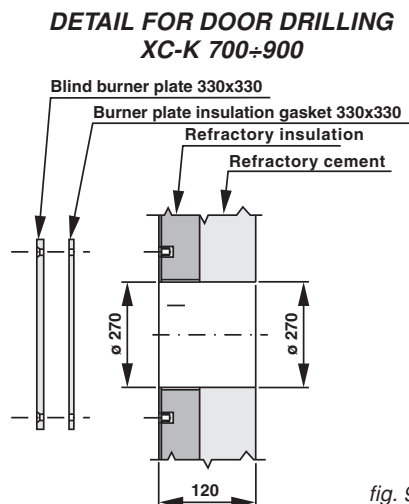

fig. 9

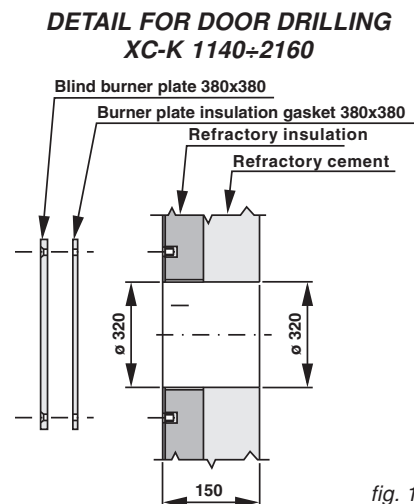

fig. 10

2.4 - OPERATING DATA

GAS-FIRED		XC-K 124	XC-K 200	XC-K 290	XC-K 400	XC-K 480	XC-K 570	XC-K 700	XC-K 900
Nominal heat output (80°-60°C)	kW	112,8	182,7	265,6	367,1	440,7	523,3	642,6	826,2
Nominal heat output (50°-30°C)	kW	124	200	290	400	480	570	700	900
Nominal heat input	kW	115,9	186,9	271	373,8	448,6	532,7	654,2	841,1
Heat efficiency at nominal load (80°-60°C)	%	97,3	97,72	98,2	98,2	98,23	98,23	98,23	98,23
Heat efficiency at nominal load (50°-30°C)	%	107	107	107	107	107	107	107	107
Heat efficiency at 30% load	%	109	109	109	109	109	109	109	109
Combustion efficiency (80°-60°C)	%	98,06	98,1	98,23	98,37	98,37	98,37	98,37	98,37
Combustion efficiency (50°-30°C)	%	99	99	99	99	99	99	99	99
Heat loss at shell (80°-60°C)	%	0,76	0,38	0,23	0,17	0,14	0,14	0,14	0,14
Heat loss at shell (50°-30°C)	%	0,68	0,34	0,21	0,15	0,12	0,12	0,12	0,12
Heat loss at chimney with burner on (80°-60°C)	%	1,94	1,90	1,77	1,63	1,63	1,63	1,63	1,63
Heat loss at chimney with burner on (50°-30°C)	%	1,03	1,03	1,03	1,03	1,03	1,03	1,03	1,03
Heat loss at chimney with burner off	%	0,05	0,05	0,05	0,05	0,05	0,05	0,05	0,05
Flue gas temperature tf-ta (80°-60°C)	°C	44	43	40	37	37	37	37	37
Flue gas temperature tf-ta (50°-30°C)	°C	22	22	22	22	22	22	22	22
CO ₂ content	%	10,3	10,3	10,3	10,3	10,3	10,3	10,3	10,3
Flue gas mass flow rate (min.-max)	kg/h	166,9	269,1	390,2	538,3	645,9	767	941,9	1211,1
Maximum condensation production (natural gas)	l/h	19,61	31,62	45,85	63,24	75,89	90,12	110,68	142,3

GAS-FIRED		XC-K 1140	XC-K 1420	XC-K 1820	XC-K 2160
Nominal heat output (80°-60°C)	kW	1046,6	1303,6	1670,8	1983
Nominal heat output (50°-30°C)	kW	1140	1420	1820	2160
Nominal heat input	kW	1065,4	1327,1	1700,9	2018,7
Heat efficiency at nominal load (80°-60°C)	%	98,23	98,23	98,23	98,23
Heat efficiency at nominal load (50°-30°C)	%	107	107	107	107
Heat efficiency at 30% load	%	109	109	109	109
Combustion efficiency (80°-60°C)	%	98,37	98,37	98,37	98,37
Combustion efficiency (50°-30°C)	%	99	99	99	99
Heat loss at shell (80°-60°C)	%	0,14	0,14	0,14	0,14
Heat loss at shell (50°-30°C)	%	0,12	0,12	0,12	0,12
Heat loss at chimney with burner on (80°-60°C)	%	1,63	1,63	1,63	1,63
Heat loss at chimney with burner on (50°-30°C)	%	1,03	1,03	1,03	1,03
Heat loss at chimney with burner off	%	0,05	0,05	0,05	0,05
Flue gas temperature tf-ta (80°-60°C)	°C	37	37	37	37
Flue gas temperature tf-ta (50°-30°C)	°C	22	22	22	22
CO ₂ content	%	10,3	10,3	10,3	10,3
Flue gas mass flow rate (min.-max)	kg/h	1534	1910,8	2449	2906,6
Maximum condensation production (natural gas)	l/h	180,24	224,52	287,76	341,52

3

INSTALLATION INSTRUCTIONS

3.1 - GENERAL WARNINGS



ATTENTION!

This boiler is intended solely for the use for which it was expressly designed.

Any other use is to be considered improper and therefore dangerous.

This boiler heats water to a temperature lower than the atmospheric pressure boiling temperature.



ATTENTION!

The appliances are designed to be installed inside suitable rooms or technical spaces only. The appliances cannot be installed or operate outdoors. Outdoor installation can cause malfunctioning and be dangerous. Choose specifically designed appliances for outdoor installation.



Before connecting the boiler, have professionally qualified personnel:

- a) Thoroughly wash all the piping of the system to remove any residue or impurities which could jeopardise proper operation of the boiler;
- b) Check that boiler is set up to operate with the available type of fuel.

This can be seen written on the package and on the technical feature plate;

- c) Check that the chimney/flue has an appropriate draught, without any bottlenecks, and that no exhausts from other appliances are inserted, unless the flue has been implemented to accommodate several utilities according to specific standards and prescriptions in force. Only after this check can the fitting between the boiler and chimney/flue be mounted;

ATTENTION!



In rooms with the presence of aggressive vapours or dust, the appliance must operate independently from the air inside the installation room!



ATTENTION!

The appliance must be installed by a qualified technician with the technical-professional requirements according to law which, under his own responsibility, guarantees compliance with standards according to good practice rules.



The boiler must be connected to a central heating system and/or domestic hot water supply network compatible with its efficiency and output.

3.2 -INSTALLATION STANDARDS

The appliance must be installed in compliance with the instructions provided in this manual.

It must be installed by a professionally qualified technician, **who shall assume the responsibility of respecting all local and/or national laws published in the official journal, as well as applicable technical standards.**

XC-K is a steel boiler which can be combined with air-blown burners operating on gas of category **II2H3+**.

Contact the gas supplying company before installing the appliance.

Directives concerning boiler rooms, building regulations and combustion heating provisions in the country of installation must also be respected.

The appliance must be installed, commissioned and undergo maintenance according to the current "state-of-the-art". This also holds for the hydraulic system, the flue exhaust system and the installation room.

Installation instructions

3.3 - HANDLING



The boiler can be handled easily, lifting it by means of upper hooks or shifting it on rollers underneath the sturdy base longerons.

If necessary for clearance purposes, the door and the smoke chamber can be removed to make it easier to enter the boiler room.

3.4 - POSITIONING IN BOILER ROOM

The boiler must be installed in compliance with standards and prescriptions in force.

The room must be well ventilated by openings with a total surface no less than 1/30 the surface of the boiler room, with a minimum of 0.5 m².

The ventilation openings must be permanent, communicate directly with the outside and be positioned high or low according to standards in force.

The location of the ventilation openings, the fuel supply circuits, electric energy supply and lighting must comply with current legal provisions in relation to the type of fuel used.

It is recommended to install the boiler as close to the chimney connection as possible.

To make it easier to clean the smoke circuit, in front of the boiler, there must be a free space no less than the length of the boiler body and, in any case, never less than 1300 mm. Check that with the door opened 90°, the distance between the door and the adjacent wall is at least the length of the burner.

The boiler can be placed directly on the floor as it is equipped with a base.

However it is useful to provide a flat, level cement plinth capable of bearing the weight of the boiler full of water.

When positioned on the plinth, the dimensions must be at least **Q** x **R** (see dimensions table).

When installation has been performed, the boiler must be perfectly horizontal and stable (to reduce vibrations and noise).

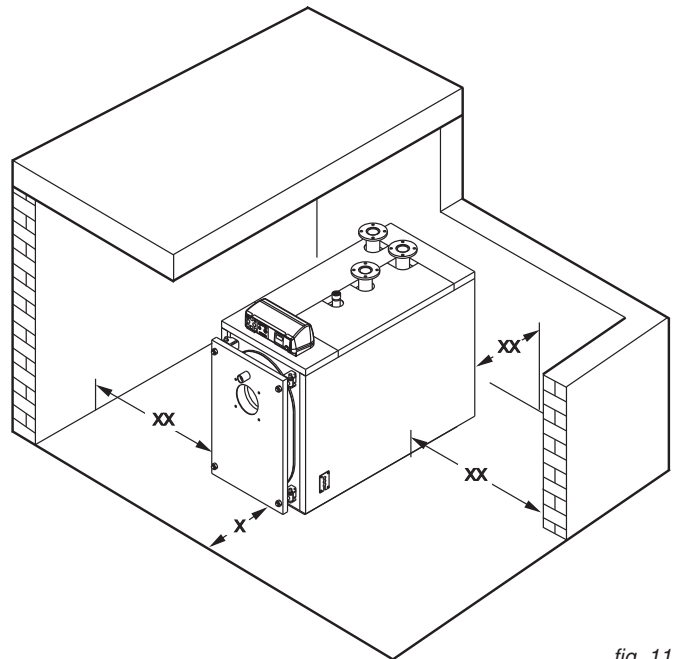

fig. 11

*x = not less than the length of the boiler body (dimensions in mm); in any case, never less than 1300 mm.
xx = see instructions to the side.*

3.5 - BURNER

The burners operating with the XC-K boilers must have the EC certification and comply with:

- Gas appliance directive (90/396/EEC);
- EMC Directive - Electromagnetic Compatibility (89/336/EEC).

They must also be approved according to the specifications:

- UNI EN 676 - air-blown burners for gaseous fuel.
- Efficiency Directive (92/42 EEC).

3.5.1 - CHOOSING THE BURNER

The correct choice and adjustment of the burner are fundamental for optimal operation of the boiler and therefore must be done carefully and not underestimated.

The burner must be chosen verifying that its firing rate (fuel capacity - combustion chamber pressure) is compatible with the same features declared for the boiler.

Remember that pressure drops on the flue side of the boiler, namely combustion chamber backpressure, refer to zero pressure at the base of the chimney.

It is also recommended that the burner blast tube be no shorter than the minimum dimension shown in the following table and that the flame which must be implemented be suitable for the characteristics of the combustion chamber.

In order to take advantage of the whole heat exchange surface of the blind bottom furnaces, use burners capable of providing a "long and narrow" flame in any operating condition, namely even at the minimum output when controlling two or more stages or modulating.

Flames which are too short cause overheating in the front of the furnace and combustion products, not sufficiently cooled, entering the smoke pipes at too high temperatures can seriously damage the generator.

The manufacturing companies of the burners can supply the dimensions of the flames which their appliances develop,

Installation instructions

especially those approved based on the standards indicated above.

Further information is provided in the chapter "Commissioning".

BOILER TYPE	ϕA mm	L mm
XC-K 124	150	230
XC-K 200	180	230
XC-K 290 ÷ XC-K 400	180	270
XC-K 480 ÷ XC-K 570	220	300
XC-K 700 ÷ XC-K 900	270	320
XC-K 1140 ÷ XC-K 1420	320	350
XC-K 1820 ÷ XC-K 2160	320	420

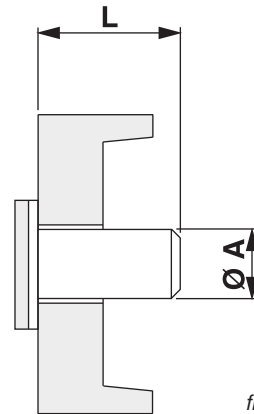

fig. 12

DIMENSIONS OF BURNER BLAST TUBE

3.5.2 - INSTALLING THE BURNER



The burner must be mounted to the door of the boiler guaranteeing perfect sealing of the combustion products.

The burner is supplied with **a piece of ceramic fiber cord which must be placed on the blast tube of the burner to fully seal the space between the blast tube and the slot in the door.**

Make sure that no gaps remain between the blast tube and the slot on the refractory material inside the door.

Should a cone larger than the diameter of the blast tube be mounted, it must be removed before mounting the burner on the support plate and put back afterwards.

With the burner mounted, check that the electric cables are

long enough to allow the door to open 90°.

For gas-fired burners, flexible hoses cannot be used for connections. Therefore it must be possible to disconnect the final section of the gas addition tube by means of a threaded or flanged joint.

3.6 - CONNECTING FLAME SIGHT GLASS TO BURNER

The flame sight glass is provided with a 1/8" threaded connection (pos. 1) upon which a 9 mm pressure test nipple is mounted. It can be used with a silicon tube to measure the backpressure in the combustion chamber.

In place of this test nipple, which must be kept, an appropriate fitting will be mounted to connect the flame sight glass directly to the pressure chamber downstream the burner fan by means of a copper tube (pos.2).

The air blown by the fan will conveniently cool the sight glass and keep it from blackening.

If the cooling tube is not connected to the sight glass, it could break.

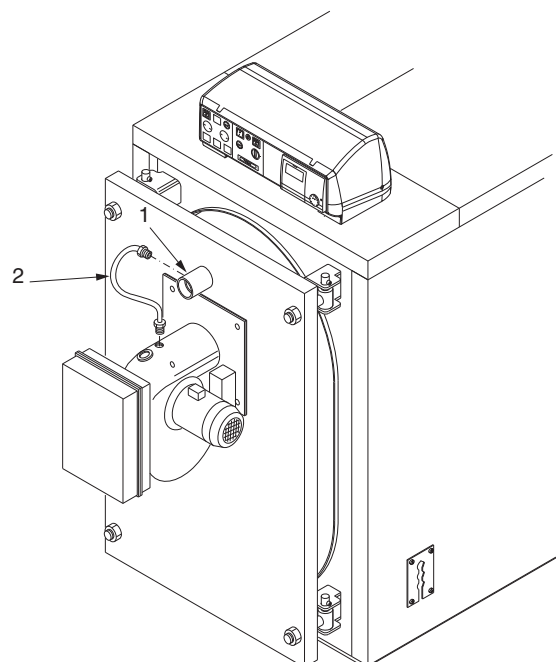

fig. 13



ATTENTION: the flame sight glass can be very hot; therefore pay the utmost attention.

Installation instructions

3.7 - FURNACE DOOR: ADJUSTMENT, OPENING AND CLOSING

3.7.1 - "XC-K 124 ÷ XC-K 900" BOILERS

For all these models, the door is hinged and fixed according to the layout in fig. 14. In these cases, the door is mounted with four equal hinges: the two on the left side are normally used as rotation hinges (from right to left), while the two on the right side are used as closing hinges; the door is then secured with 4 nuts.

It will be exactly the opposite when the door is opened from the left to the right. To invert rotation, just move the rear locknuts to the opposite side.

The following adjustments can be made on the door of these boiler models:

- A) Vertical adjustment:** only by inserting suitably thick washers below the hinge which the door turns on.
- B) Crosswise rotation:** loosening the hinges fixed on the front plate of the boiler and moving them sideways.
- C) Axial rotation:** screwing different tightening nuts.

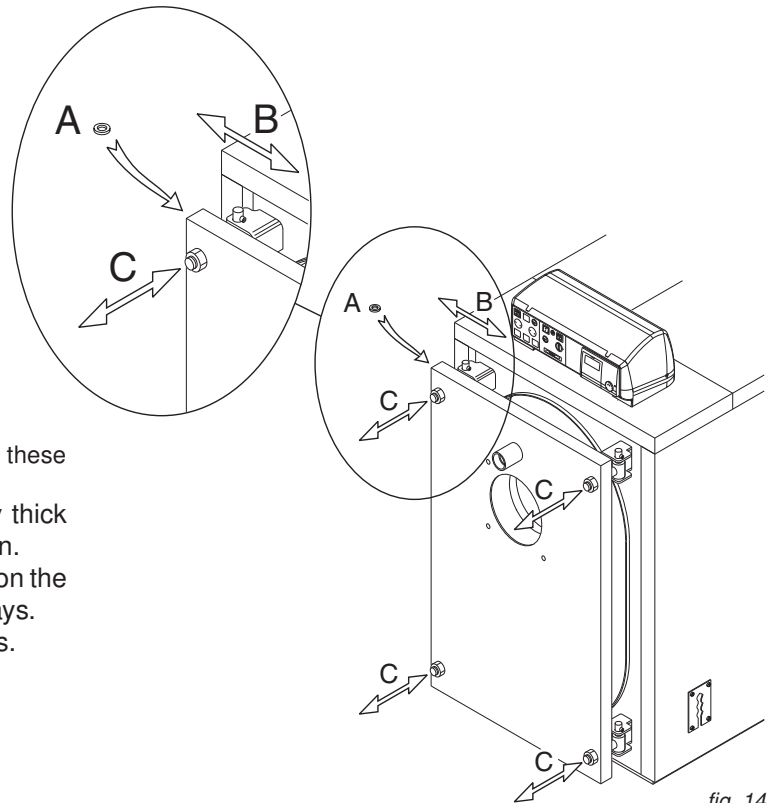

fig. 14

3.7.2 - "XC-K 1140 ÷ XC-K 1420" BOILERS

For all these models, the door is hinged and fixed according to the layout in fig. 15.

In these cases, the two hinges on the left are normally used as rotation hinges (from right to left), while the two on the right side are used as closing hinges. It will be exactly the opposite when the door is opened from the left to the right.

To invert rotation, just move the rear locknuts to the opposite side.

The following adjustments can be made on the door of these boiler models:

- A) Vertical adjustment:** by acting on the nut of the upper hinge pin which the door turns on.
- B) Crosswise rotation:** loosening the hinges fixed on the front plate of the boiler and moving them sideways.
- C) Axial rotation:** screwing different tightening nuts.

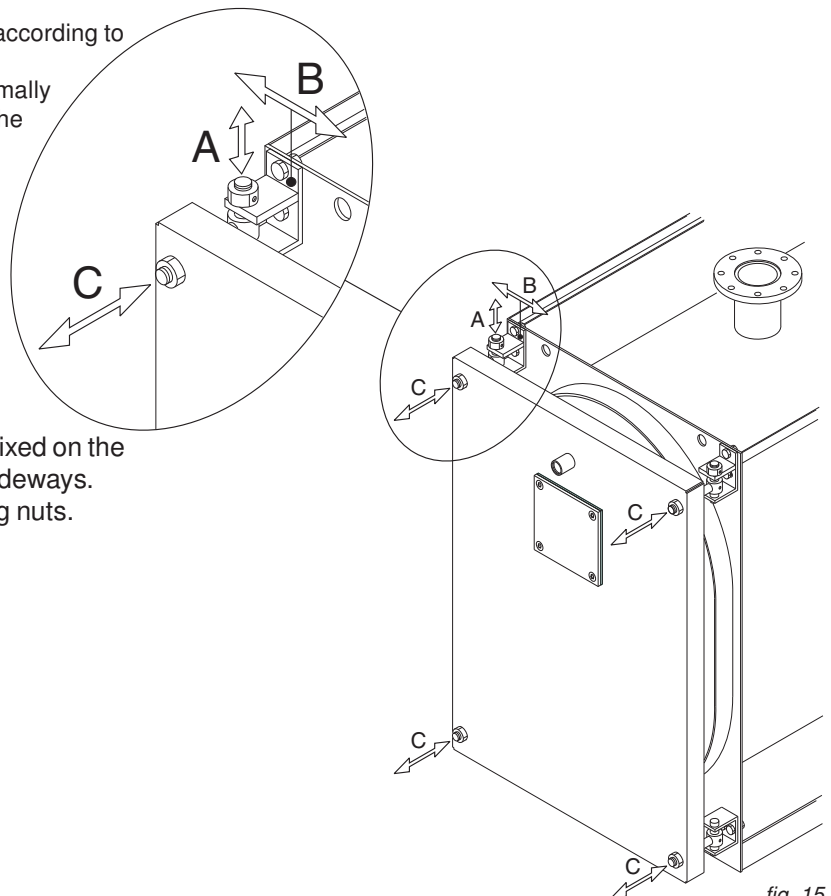

fig. 15

3.7.3 - "XC-K 1820 ÷ XC-K 2160" BOILERS

For all these models, the door is hinged and fixed according to the layout in fig. 16.

In these cases, the two hinges on the left are normally used as rotation hinges (from right to left), while the two on the right side are used as closing hinges.

It will be exactly the opposite when the door is opened from the left to the right.

To invert rotation, just move the rear locknuts to the opposite side.

The following adjustments can be made on the door of these boiler models:

- A) Vertical adjustment:** by acting on the nut of the upper hinge pin which the door turns on.
- B) Crosswise rotation:** loosening the hinges fixed on the front plate of the boiler and moving them sideways.
- C) Axial rotation:** screwing different tightening nuts.

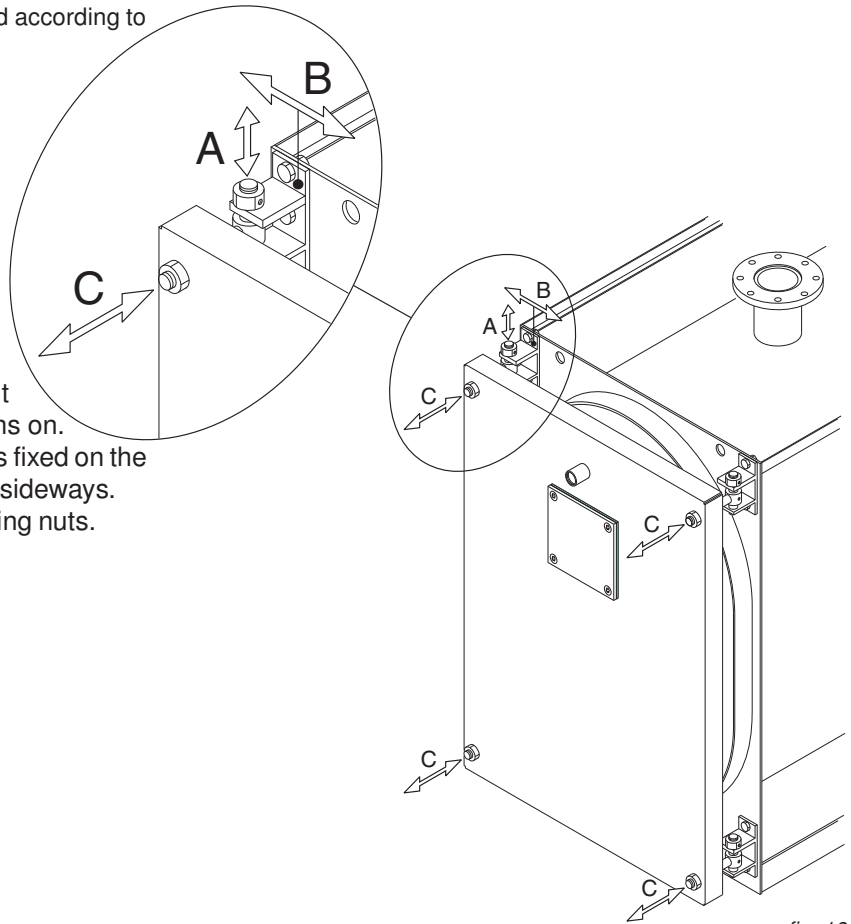

fig. 16

3.7.4 - IMPORTANT NOTE

Before opening the door of the furnace, take the following safety measures:

- Close the fuel supply to the burner.
- Cool the boiler off by having water circulate and then disconnect electrical power.
- Place a sign on the boiler with the following text: **DO**

**NOT USE, BOILER MAINTENANCE UNDERWAY,
OUT OF SERVICE.**

Installation instructions

3.8 - CONNECTING FLUE EXHAUST PIPE

To connect the flue gas exhaust pipe, local and national standards must be respected.

The XC-K boiler can be attached to the chimney in different ways; straight pipes or elbows can be used to exit from the rear, on the left, on the right, or else vertically to enter into the flue at a higher level.

It is recommended to insulate the pipe connecting to the chimney to reduce heat loss and noise.

Along the section connecting the boiler to the flue there must be suitable points for measuring flue gas temperature and analysing combustion products.

Use only exhaust pipes suitable for the type of fuel used.



The supplier will have no contractual or extra-contractual liability for damage caused due to incorrect installation and use and anyway failure to comply with the instructions provided by the manufacturer.

When performing replacement installations, ALWAYS replace the flue gas exhaust accessory as well. The flue must comply with standards in force.

3.9 - DRAINING CONDENSATION CONDENSATION UPON COMMISSIONING

While the boiler is reaching the operating temperature, a good amount of condensation can be formed due to the low temperature of the flue gas.

In these conditions, it could be useful to have the condensation drained into the sewer. For this purpose, the smoke chamber is equipped with an attachment which the exhaust pipes will be connected to according to the following notes

When the operating temperature has been reached - see notes in chap. 3.28 "COMMISSIONING" - it is important to check whether more condensation has been formed.

If not, after having verified the actual fuel flow rates, the operating temperature should be increased.

The condensation drainage in the sewer must be:

- implemented as to prevent releasing gaseous combustion products into the environment or sewer (siphoning);
- dimensioned and implemented to allow the correct outflow of liquid waste preventing any leakage;
- installed in such a way to prevent liquid from freezing in the intended operating conditions;

- mixed for example with household wastewater (washer, dishwasher drainage, etc.) for the most part with basic pH in order to form a buffer solution to then be introduced in the sewer system.

Condensation must not stagnate in the combustion product drainage system (for this reason the evacuation duct must slope at least 30 mm/m towards the drain) except for a liquid seal, present in the drainage siphon for the evacuation of combustion products (which must be filled after assembly and must remain at least 25 mm high with the boiler running - see fig. 17).

Do not discharge condensation through gutter drainpipes due to the risk of turning into ice and the deterioration of the materials usually used to make the drainpipes (consult local hygiene regulations).

The drain fitting must be visible.

Due to the acidity level of the condensation (pH from 3 to 5) only suitable plastic materials must be used for the drain piping (special optional kits with neutralizer salts for acid condensation are available).

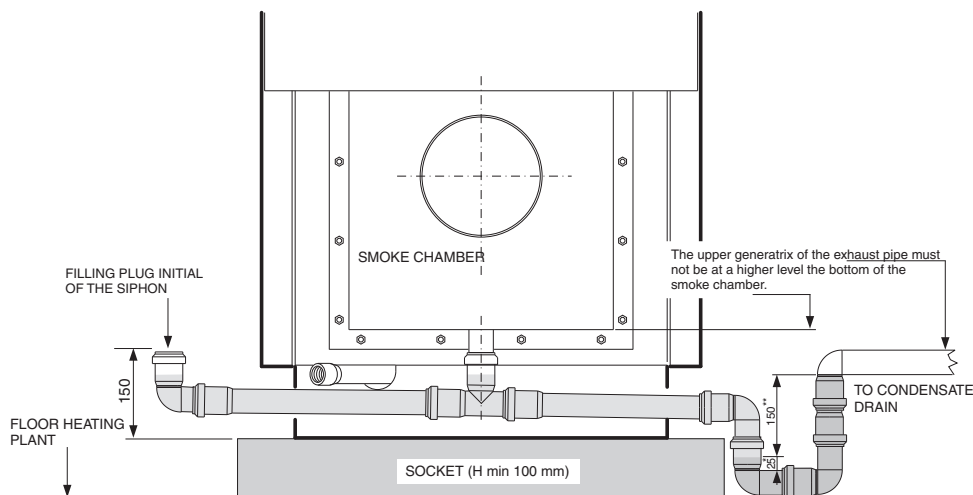

fig. 17

* Minimum safety siphon set by the standard

** Minimum head with boiler running at maximum power.

If you do not want to or cannot create a plinth, the boiler can be mounted at ground level and a sump at least 100 mm deep can be made to house the siphon.

3.10 - CONNECTING BOILER TO SYSTEM



Attention!

Before connecting the boiler to the heating system, thoroughly clean the piping with an appropriate product in order to eliminate metallic residue from processing and welding, oil and grease which could be present and which, reaching the boiler, could alter its functioning.

Do not use solvents to wash the system as they could damage the system and/or its components.

Failure to comply with the instructions of the following manual can cause damage to persons, animals and objects for which the manufacturer cannot be held responsible.



Attention!

Make sure that there are no mechanical tension points while connecting the pipes to avoid the risk of leakage!

Heating flow and return pipes must be connected to the boiler at the respective fittings as indicated on pages 8, 9 and 10.

For the dimensioning of the heating circuit pipes, you must take into account pressure drops caused by radiators, thermostatic valves, radiator stopping valves and by the configuration of the system.

The laying of the pipes must be designed taking every necessary precaution to avoid air pockets and to facilitate continuous degassing of the system.



Make sure that the pipes of the water and heating system are not used as earthing electrodes of the electric or telephone system.

There absolutely not suitable for this use.

Serious damage could result for the piping, boiler and radiators in a short amount of time.

Heating system safety valve drain

Provide a drain pipe with a funnel and a siphon leading to an appropriate drainage at the heating safety valve. This drainage must be controlled on sight.



Attention!

If this precaution is not taken, triggering of the safety valve can cause damage to persons, animals and objects for which the manufacturer cannot be held responsible.

Connection of expansion vessel



XC-K boilers are suitable for operating with forced water circulation both with the expansion vessel opened or closed.

An expansion vessel is always necessary to compensate the increase in water volume due to heating.

The connection pipes of the expansion vessel will start from the T4 attachment (see DIMENSIONS TABLES) and must have no shut-off valve.

Connection of filling/draining tap

A specific tap can be connected to the T5 attachment at the rear of the boiler for filling and draining.

3.11 - FILLING THE SYSTEM



Attention!

Do not mix the heating water with incorrect concentrations of antifreeze or anti-corrosion substances! This could damage the gaskets and cause noise during operation.

Unical will not be held liable for damage to persons, animals or objects due to failure to comply with the instruction above.

When all system connections have been completed, the circuit can be filled.

This operation must be performed carefully, respecting the following phases:

- open the radiator air release valves.
- open the filling tap gradually, making sure that the automatic

air release valves installed on the system work properly.

- close the radiator air release valves as soon as water comes out.
- check the pressure gauge until pressure reaches approximately 1 bar.
- close the filling tap and bleed air once again through the radiator air release valves.
- make sure that all the connections are watertight.
- after commissioning the boiler and bringing the system to the operating temperature, stop the pumps and repeat the air bleed operations.
- let the system cool off and, if necessary, return the water pressure to 1 bar.

Installation instructions



NOTE

The water pressure in the heating system must not drop below 1 bar; open the filling tap when pressure is too low. This operation must be performed with the system cool.



NOTE

If the boiler was without electric power, after certain idle period, the pump could be blocked. Before turning on the main switch, the pump must be unblocked by operating as follows:
Introduce a screwdriver in the hole below the protective screw in the centre of the pump intended for this purpose and turn the pump shaft clockwise.
After having unblocked the pump, tighten the protective screw and make sure there is no water leakage.



ATTENTION!

After removing the protective screw, a small amount of water could leak out. Dry off all wet surfaces before powering the boiler.

3.12- CONNECTING GAS



Danger!

The gas connection must be carried out only by a qualified installer who must respect and apply that foreseen by relevant laws in force in the local prescriptions of the supply company. Incorrect installation can cause damage to persons, animals and objects for which the manufacturer cannot be held responsible.



Before installation, we recommend a thorough inner cleaning of all fuel adduction piping to remove any residue which could jeopardise proper operation of the boiler.



Attention!

Make sure that there are no mechanical tension points while connecting gas to avoid the risk of leakage!



Perceiving the smell of gas:

- Do not turn electric switches on or off, use a telephone or any other object which can create sparks;
- Immediately open doors and windows to create an air current to air out the room;
- Shut the gas cocks;
- Request the intervention of professionally qualified personnel.



As a precaution against gas leaks, we recommend installing a monitoring and protection system consisting in a gas leak detector coupled with a shut-off solenoid valve on the gas feed line.

The supply pipes must have a cross-section sufficient for the flow rate of the burner.

You should nonetheless comply with the "General installation regulations" laid down in the standards.

Before commissioning an internal gas distribution system and therefore before connecting it to the gas meter, check its sealing carefully.

If any part of the system is out of sight, the sealing test must be done before the pipes are covered.

Before connecting the appliances, the system must be tested with air or inert gas at a pressure of at least 100 mbar.

The following operations and checks must also be performed while commissioning the system:

- Open the meter and air release valve to bleed the air from the piping of the appliances, proceeding one appliance after another.
- With the appliances closed, check that there are no gas leaks. The pressure gauge must show no pressure drop during the second quarter of an hour from the start of the test. Gas leaks must be found with a soapy solution or similar product and eliminated.
Never look for gas leaks with an open flame.

3.13 - PACKAGING

XC-K boilers are supplied complete with the door and smoke chamber assembled, while the casing and insulation are included in separate cardboard packs.

The panel and accessories are inside the combustion chamber. Before starting installation, make sure that the length and width of the boiler body received correspond respectively to the dimensions **P**, **Q** and **R** of the boiler you have ordered, provided on the previous tables, and that the boxes containing the casing, or part of it, are marked as in the table at the bottom of the page.

The casing of boilers from XC-K 124 to XC-K 400, complete with insulation mattresses, **is contained in one box.**

The casing of boilers from XC-K 480 to XC-K 2160 is contained in 3 boxes.

In addition to the panel board packed in its own box, the following accessories are found in the combustion chamber:

- 1 box containing hydraulic connection flanges, with relative gaskets and bolts (where included).
- ceramic fibre cord to insulate between burner blast tube and door.



plastic bags, etc.) **must be kept out of the reach of children as they are potential sources of danger.**

Unical will not be held liable for damage to persons, animals or objects due to failure to comply with the instruction above.

The document envelope contains:

- System manager operating instructions
- Installation and maintenance instruction booklet
- Warranty
- Local ventilation requirements label.



Upon reception, make sure that the supply is complete and undamaged.

The packaging elements (cardboard box, straps,

N.B. For models from **XC-K 124 to XC-K 400** (ref. fig. 18 and 19), the casing and insulation are contained in 1 box marked:

43607 (XC-K 124)
43608 (XC-K 200)
43609 (XC-K 290)
43610 (XC-K 400)

N.B. For models from **XC-K 480 to XC-K 2160** (ref. fig. 19 and 20), the casing and insulation are contained in 3 boxes marked:

43611 (front casing XC-K 480)
43612 (rear casing XC-K 480)
43613 (top casing XC-K 480)
43614 (front casing XC-K 570)
43615 (rear casing XC-K 570)
43616 (top casing XC-K 570)
43617 (front casing XC-K 700)
43618 (rear casing XC-K 700)
43619 (top casing XC-K 700)
43620 (front casing XC-K 900)
43621 (rear casing XC-K 900)
43622 (top casing XC-K 900)

43623 (front casing XC-K 1140)
43624 (rear casing XC-K 1140)
43625 (top casing XC-K 1140)
43626 (front casing XC-K 1420)
43627 (rear casing XC-K 1420)
43628 (top casing XC-K 1420)
43629 (front casing XC-K 1820)
43630 (rear casing XC-K 1820)
43631 (top casing XC-K 1820)
43632 (front casing XC-K 2160)
43633 (rear casing XC-K 2160)
43634 (top casing XC-K 2160)

Installation instructions

3.14 - ASSEMBLING CASING

XC-K 124

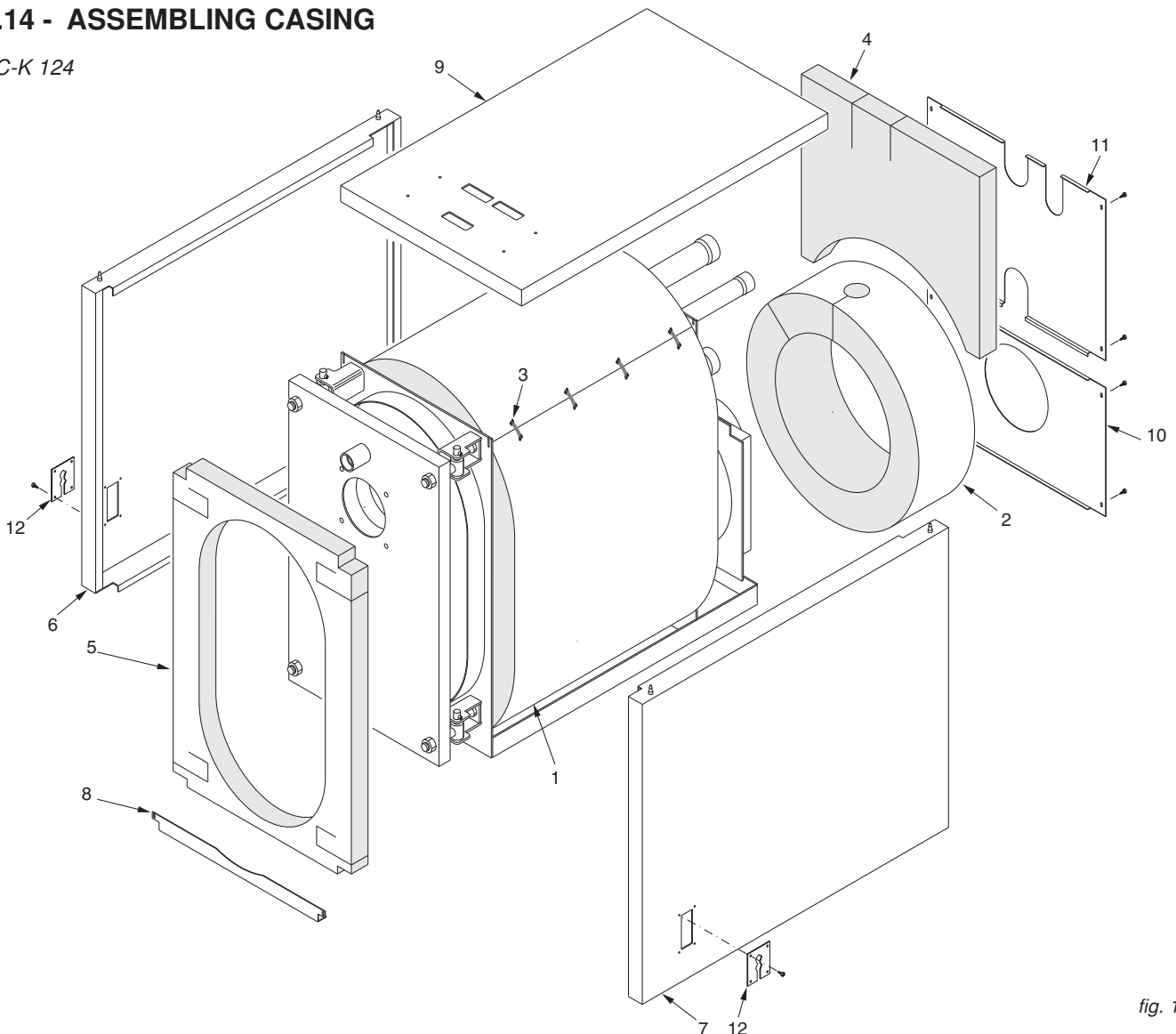

fig. 18

Assembly sequence (Ref. fig. 18, 21)

- A) Mount the insulation jackets (pos. 1 and 2) of the boiler body and secure the 2 edges with the elastic straps (pos. 3) supplied in the accessory box, hooking them to the external fabric part of the insulation.
- B) Mount the rear insulation (pos. 4).
- C) Open the boiler door and mount the front insulation (pos. 5) fitting the support hinges of the door into the pre-cuts.
- D) Position the side panels (pos. 6 e 7) with the lower bend inside the L-shaped profile at the base of the boiler body and hook the upper part in the plate cuts. To determine which is the right side and which is the left side, refer to the cable gland plates (pos. 12): they must face the front of the boiler.
- E) Connect the front reinforcement profile (pos. 8) to the two sides.
- F) Rotate the cover of the panel board frontwards after having removed the two screws on the side and insert the electric inlet cables and the outlet probe capillaries through the slots at the base.
- G) Fit the panel board to the upper panel (pos. 9).
Fit the upper panel (pos. 9), complete with panel board, to the two sides of the casing.
- H) Insert into the conduits the bulbs of the instruments as indicated in fig. 21 and, depending on the panel board installed on the boiler, the probes as illustrated in the electric-hydraulic diagrams (page 26).
Wire the panel to the power line, to the burner and to any pumps, etc.
Close the cover of the electric control board.
Have the plug of the burner and the power cables of the boiler pass through the side plate (pos. 11) on the preferred side and secure the cables with the cable gland supplied.
- I) Fasten the plates (pos. 11) to the sides of the casing.
Mount the rear panels (pos. 10 and 11).
Fix the boiler data plate to the side panel after having greased the relevant part with the specific solvent.

The plates are included in the document envelope.

XC-K 200÷XC-K 1140

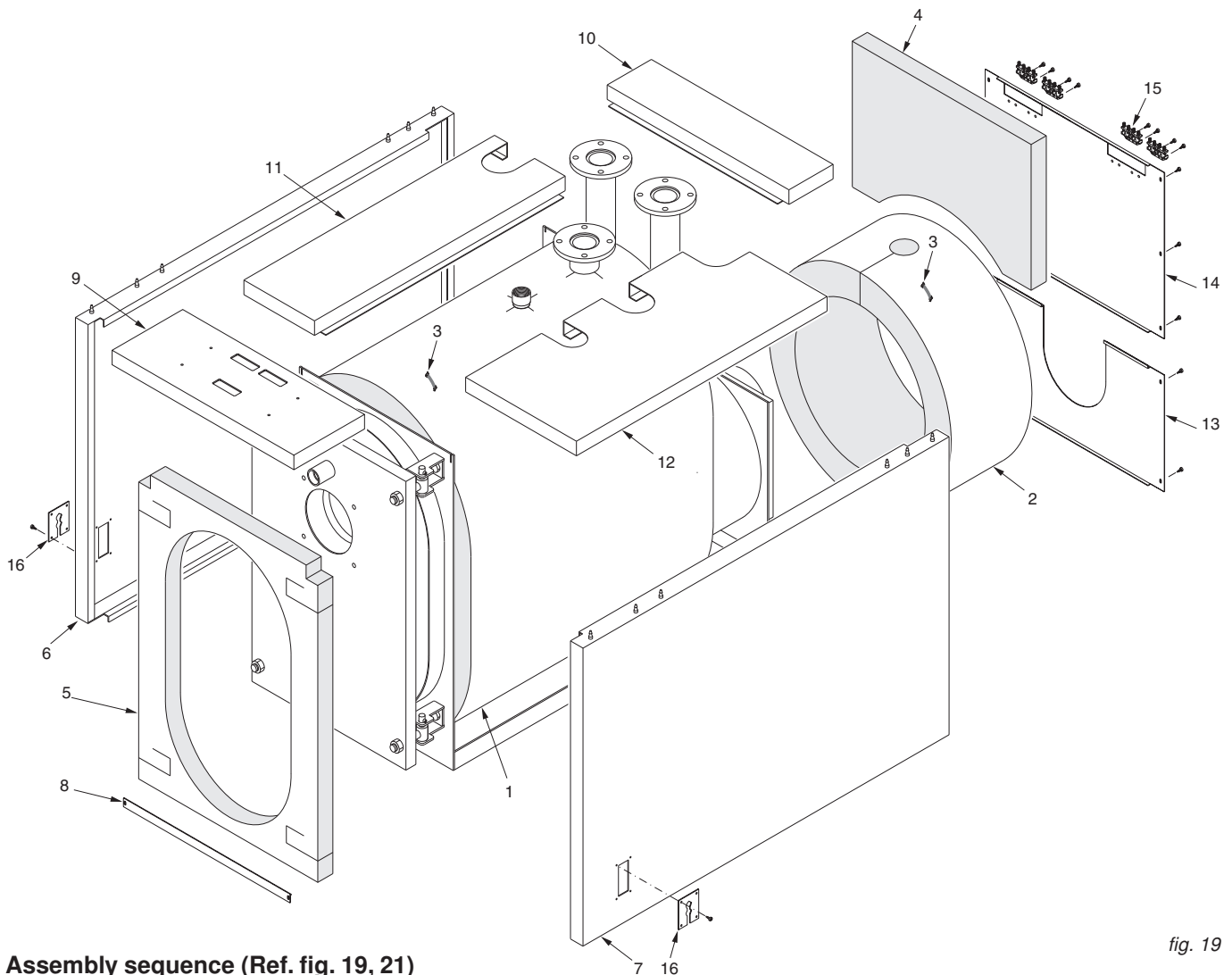

fig. 19

Assembly sequence (Ref. fig. 19, 21)

- A) Mount the insulation jackets (pos. 1 and 2) of the boiler body and secure the 2 edges with the elastic straps (pos. 3) supplied in the accessory box, hooking them to the external fabric part of the insulation.
- B) Mount the rear insulation (pos. 4).
- C) Open the boiler door and mount the front insulation (pos. 5) fitting the support hinges of the door into the pre-cuts.
- D) Position the side panels (pos. 6 and 7) with the lower bend inside the L-shaped profile at the base of the boiler body and hook the upper part to the reinforced profiles.
To determine which is the right side and which is the left side, refer to the cable gland plates (pos. 16): they must face the front of the boiler.
N.B. from model XC-K 480 to XC-K 1140, the sides have two pieces each.
- E) Connect the front reinforcement profile (pos. 8) to the two sides.
- F) Rotate the cover of the panel board frontwards after having removed the two screws on the side and insert the electric inlet cables and the outlet probe capillaries through the slots at the base.
Fit the panel board to the upper panel (pos. 9).
Fit the upper panel (pos. 9), complete with panel board, to the two sides of the casing.
- G) Insert into the conduits the bulbs of the instruments as indicated in fig. 21 and, depending on the panel board installed on the boiler, the probes as illustrated in the electric-hydraulic diagrams (page 26).
Wire the panel to the power line, to the burner and to any pumps, etc.
Close the cover of the electric control board.
Guide the burner plug through the side plate (pos. 16) on the preferred side and secure the cables with the cable gland supplied.
Fasten the plates (pos. 16) to the sides of the casing.
- H) Mount the rear panels (pos. 13 and 14).
Mount the cable clamps (pos. 15) to the upper rear panel.
Secure the electric cables coming out from the rear of the boiler with the cable clamps, tightening them moderately.
- I) Fit the upper rear panel (pos. 10) to the sides of the casing.
- L) Fit the upper longitudinal panels (pos. 11 and 12) to the sides of the casing.
- M) Fix the boiler data plate to the side panel after having greased the relevant part with the specific solvent.
The plates are included in the document envelope.

Installation instructions

XC-K 1420÷XC-K 2160

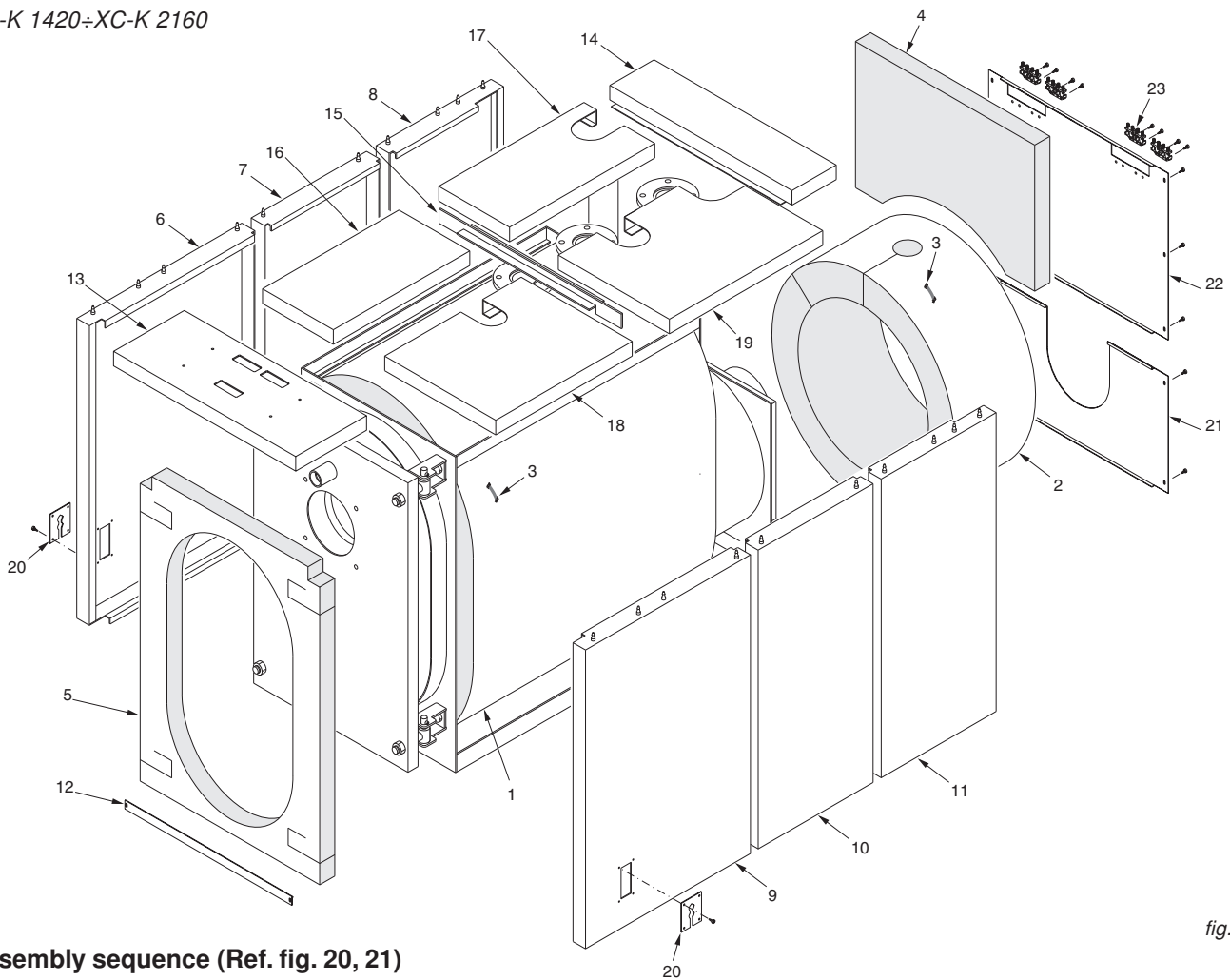

fig. 20

Assembly sequence (Ref. fig. 20, 21)

- A) Mount the insulation jackets (pos. 1 and 2) of the boiler body and secure the 2 edges with the elastic straps (pos. 3) supplied in the accessory box, hooking them to the external fabric part of the insulation.
- B) Mount the rear insulation (pos. 4).
- C) Open the boiler door and mount the front insulation (pos. 5) fitting the support hinges of the door into the pre-cuts.
- D) Position the left side panels (pos. 6, 7 and 8) with the lower bend inside the L-shaped profile at the base of the boiler body and hook the upper part to the reinforced profiles. To determine which is the front side, refer to the cable gland plates (pos. 20): they must face the front of the boiler.
- E) Position the right side panels (pos. 9, 10 and 11) with the lower bend inside the L-shaped profile at the base of the boiler body and hook the upper part to the reinforced profiles. To determine which is the front side, refer to the cable gland plates (pos. 20): they must face the front of the boiler.
- F) Connect the front reinforcement profile (pos. 12) to the two sides (pos. 6 and 9).
- G) Rotate the cover of the panel board frontwards after having removed the two screws on the side and insert the electric inlet cables and the outlet probe capillaries through the slots at the base. Fit the panel board to the upper panel (pos. 13). Fit the upper panel (pos. 13), complete with panel board, to the two sides of the casing.
- H) Insert into the conduits the bulbs of the instruments as indicated in fig. 21 and, depending on the panel board installed on the boiler, the probes as illustrated in the electric-hydraulic diagrams (page 26). Wire the panel to the power line, to the burner and to any pumps, etc. Close the cover of the electric control board. Guide the burner plug through the side plate (pos. 20) on the preferred side and secure the cables with the cable gland supplied. Fasten the plates (pos. 20) to the sides of the casing.
- I) Mount the rear panels (pos. 21 and 22). Mount the cable clamps (pos. 23) to the upper rear panel. Secure the electric cables coming out from the rear of the boiler with the cable clamps, tightening them moderately.
- L) Fit the upper rear panel (pos. 14) to the sides of the casing.
- M) Position the upper support panels (pos. 15) on the sides of the casing.
- N) Fit the upper left (pos. 16 and 17) and right (pos. 18 and 19) longitudinal panels to the support (pos. 15) and hook them to the sides of the casing.
- O) Fix the boiler data plate to the side panel after having greased the relevant part with the specific solvent.

The plates are included in the document envelope.

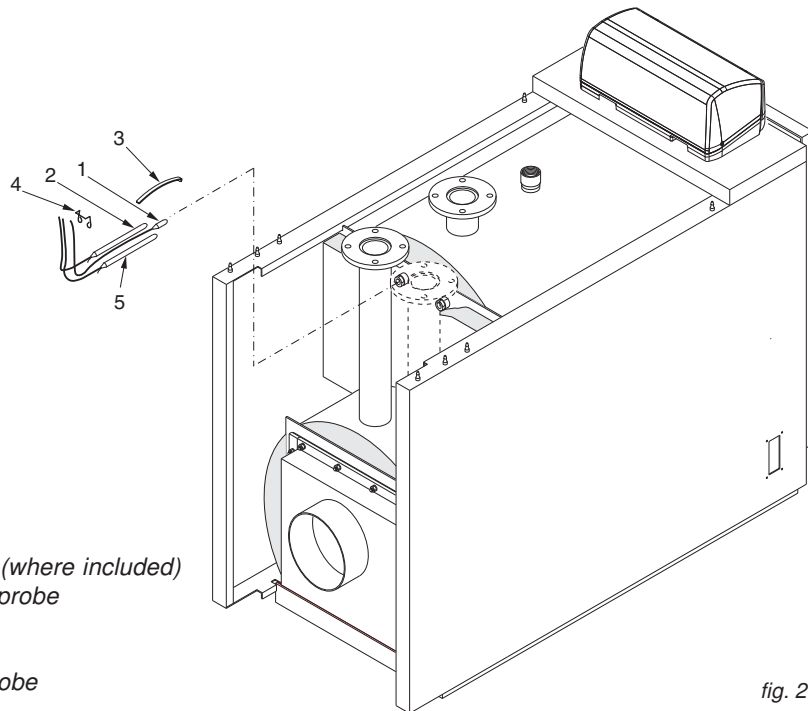

fig. 21

- 1 Thermometer probe (where included)
- 2 Working thermostat probe
- 3 Contact spring
- 4 Safety spring
- 5 Safety thermostat probe

3.15- ELECTRICAL CONNECTIONS

General warnings

The electrical safety of the appliance is guaranteed only when it has been properly connected to an efficient earthing system carried out as intended by safety standards in force: pipes of the gas, water and heating systems are absolutely unsuitable as earthing electrodes.

It is necessary to verify this fundamental safety requirement. If in doubt, have the electric system carefully checked by professionally qualified personnel as the manufacturer is not liable for damage caused by failure to provide an earthing system.

Have professionally qualified personnel check that the electric system is adequate for the maximum power absorbed by the appliance, indicated on the data plate. Make sure in particular that the cross-section of the cables is suitable for the power absorbed by the appliance.

Adapters, multiple sockets and/or extension cords cannot be used to power the appliance.

Use of any type of component using electric energy requires the observance of some fundamental rules, such as:

- do not touch the appliance with wet and/or moist parts of the body and/or in bare feet;
- do not pull the electric cables;
- do not leave the appliance exposed to atmospheric agents (rain, sun, etc.) unless expressly designed;
- do not allow children or unskilled persons to use the appliance.

230V electric power supply connection

The electrical connections are illustrated in chapters 3.16, 3.17, 3.18, 3.19 and 3.21 for modulating burners and chapters 3.22, 3.23, 3.24, 3.25 and 3.27 for dual-stage burners.

Boiler installation requires connection to a 230 V - 50 Hz electric mains: this connection must be performed up to standard as intended by current IEC regulations.



Danger!

Only a qualified technician may perform the electrical installation. Before performing connections or any type of operation on electrical parts, always disconnect electrical power and make sure that it cannot be reconnected accidentally.

Remember that a bipolar switch must be installed on the boiler power line with over 3 mm between contacts, easy to access, making maintenance quick and safe.



The power cable must be replaced by authorised technical personnel. Failure to comply with the above can jeopardise the safety of the appliance.

Installation instructions

3.16 - MODULATING MASTER PANEL BOARD code 37892

The main switch [14] powers the board and the equipment connected to it.

The switches [18] and [19] control the burner and P1 pump if the boiler operates in cascade.

The switches [20] and [21] control the Z1 pump (direct) and Z2 pump (mixed).

The working temperature of the boiler is regulated by the heating controller: to achieve this, the thermostat must be placed at maximum full-scale pos. [33].

Modulation of the burner will be managed by heat control.

The electric power line of the boiler's control board must have a switch with protective fuses.

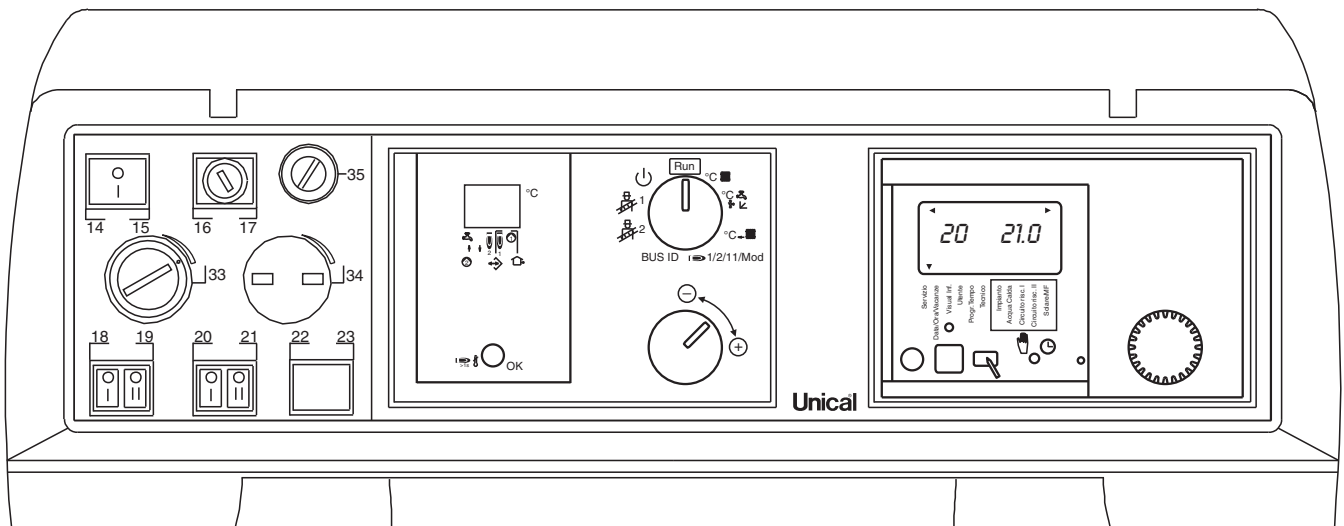

fig. 22

14 Main switch with indicator light

16 General fuse

18 Burner switch

19 P1 system pump switch (cascade)

20 Pz1 direct zone system pump switch

21 Pz2 mixed zone system pump switch

33 Working thermostat

35 Safety thermostat

For use of the panel board, see the system manager instruction booklet

As far as the practical connection and operating diagrams are concerned, see the documentation supplied inside the panel board code 37892

The heating controller probes (boiler, storage tank, external, flow) are included in the supply; the ambient probes 1 and 2 are optional; the mixer valve and relative control motor are not included in the supply.

Should ambient probes be mounted (optional), the room

temperature will only be determined with the boiler curve set by the program.

Should 2 boilers in cascade be mounted, see chapters 3.19, 3.20, 3.21.

3.17 - PROGRAMMING HEATING CONTROLLERS WITH SINGLE BOILER

For that which concerns adjustment and programming of the heating modules, see the instruction booklets attached to the individual heating controller.

The following are the default parameters which "cannot be

modified".

As far as parameters which can be programmed by the user according to his requirements, see the system manager instruction book.

PARAMETERS PROGRAMMABLE BY TECHNICIAN AND PROTECTED BY ACCESS CODE FOR HEATING CONTROLLER type E8.5064

INSTALLATION			
Description	Value range	Default	Individual values
CODE NUMBER	0000 - 9999	ENTRY	
CODE NUMBER (adjustment)	0000 - 9999	0000	
BOILER BUS ID, 01 - 08	----	
BUS ID 1	(00), 01 - 015	01	
BUS ID 2	(00), 01 - 016	02	
AF SUPPLY	00,01 (OFF/ON)	01 (ON)	
BUS CONNECTION	0,01	01	
BUS SUPPLY	00,01 (OFF/ON)	01 (ON)	
TEMPERATURE MASTER	00, 01 (OFF / ON)	01 (ON)	
MAX-T HS1 MAX T-HEADER	30 °C - 110 °C	85 °C	
MIN-T HS1 MIN T-HEADER	10 °C - 80 °C	10 °C	
MAX-T HS2	30 °C - 110 °C	85 °C	
MIN-T HS2	10 °C - 80 °C	10 °C	
VOLTAGE CURVE	0 - 11	11	
CURVE 11-U2	0,00-10,00V	0V	
CURVE 11-U2	0,00-10,00V	10V	
CURVE 11-T1	00 - 120 °C	0 °C	
CURVE 11-T2	00 - 120 °C	100 °C	
CURVE 11-UA	0,00-10,00V	0V	
T-WARM-UP	10 °C - 85 °C	10	
MINIMUM LIMIT	00, 01, 02	00	
HYSTERESIS	2K - 20K	5	
HYSTERESIS TIME	00 - 30 min	00 min	
BOILER DETECTED	DISPLAY ONLY		
OUTPUT LEVEL	00 - 1000kW	* see note	
NEW CONFIGURATION	00,01 (OFF/ON)		
MINIMUM MODULATION CASCADE	00 - 100	00	
DHW LEVELS	00 - 08	00	
CONTROL VARIANCE	(K)	DISPLAY	
NOMINAL OUTPUT INDEX	0 - 100%	DISPLAY	
SWITCH VALUE	(-99) - 0 - (99)	DISPLAY	
BLOCK TIME	REMAINING (min)	DISPLAY	
MAXIMUM BOILER TEMPERATURE	50 - 110°C	85	
BOILER DYNAMICS UPWARD	20 - 500K	30K	
BOILER DYNAMICS DOWNWARD	20 - 500K	20K	
RESET TIME	5 - 500	50	
MODULATION MAX	0% - 100%	80%	
MODULATION MIN	0% - 100%	50%	
MIN MODULATION HS	0% - 100%	0%	
MODULATION DHW	40% - 100%	80%	
BOILER SEQUENCE 1	----	12345678	
BOILER SEQUENCE 2	----	87654321	

Installation instructions

Description	Value range	Default	Individual values
SEQUENCE MODE	01 - 06	01	
SEQUENCE CHANGE	10 - 800 HOURS	200 HOURS	
CYCLE BLOCK	00 min - 30 min	00 min	
HYSTERESIS BURNER 2	2K - 20K	2K	
BOILER COOLING FUNCTION	00 - 01	00	
BOILER COOLING TEMPERATURE	30°C - 120°C	95	
HS 1 TYPE	00 - 06	06	
HS 1 BUS	00 - 04	04	
HS 2 TYPE	00 - 05	00	
HS 2 STORAGE TANK	01 - 03	00	
BUFFER	01 - 01 - 02	00	
SCREED	00, 01 (OFF / ON)	00 OFF	
SCREED PROGRAM	** see note		

* Set value of first stage of first boiler at 1, in the second leave dashes.
All other boiler stages must be disabled.

** See E8.5064 heating controller instruction book

DOMESTIC HOT WATER PRODUCTION			
Description	Value range	Default	Individual values
CHARGE PUMP	00 - 01 (OFF / ON)	01 (ON)	
PARALLEL PUMP RUNNING	00 , 01, 02, 03	01	
T DHW	00K - 50K	20K	
DHW HYSTERESIS	5K - 30K	5 degrees	
DHW FOLLOWUP	00 min - 30 min	00 min	
THERMOSTAT INPUT	00, 01 (OFF / ON)	00 OFF	
THERMOSTAT FUNCTIONING	00, 01 (OFF / ON)	00 OFF	
LOAD THROUGH	00, 01 (OFF / ON)	00 OFF	
RETURN	Exit level using		

HEATING CIRCUIT 1			
Description	Value range	Default	Individual values
HEATING CIRCUIT FUNCTION	00 - 04	0	
PUMP MODE	00 - 03	0	
MIXER OPEN	5 - 25	—	
MIXER CLOSED	5 - 25	—	
MAX FLOW TEMPERATURE	20 °C - 110 °C	80 °C	
MIN FLOW TEMPERATURE	10 °C - 110 °C	30 °C	
FROST PROTECTION TEMP	(-15)°C - (5)°C	0 °C	
OUTSIDE TEMP DELAY	0:00 - 24:00	0.00	
HEATING SLOPE DISTANCE	00K - 50K	5 °C	
B-HEAT SINK	00 - 01 (OFF / ON)	01	
RETURN	Exit level using		

HEATING CIRCUIT 2			
Description	Value range	Default	Individual values
HEATING CIRCUIT FUNCTION	00 - 04	0	
PUMP MODE	00 - 03	0	
MIXER OPEN	5 - 25	----	
MIXER CLOSED	5 - 25	----	
MAX FLOW TEMPERATURE	20 °C - 110 °C	45 °C	
MIN FLOW TEMPERATURE	10 °C - 110 °C	10 °C	
FROST PROTECTION TEMP	(-15)°C - (5)°C	0 °C	
OUTSIDE TEMP DELAY	0:00 - 24:00	0.00	
HEATING SLOPE DISTANCE	00K - 50K	5 °C	
B-HEAT SINK	00 - 01 (OFF / ON)	01	
RETURN	Exit level using		

SOLAR M/F			
Description	Value range	Default	Individual values
MF (1-4) FUNCTION	00 - 26	00,00,01,02	
MF (1-4) T- NOM	00 - 03	30°C	
MF (1 - 4) HYSTERESIS	5 - 25	5°C	
F 15 FUNCTION	5 - 25	0	
RETURN	Exit level using		

PARAMETERS PROGRAMMABLE BY TECHNICIAN FOR HEATING CONTROLLER
Lago Basic 0201 RV 1

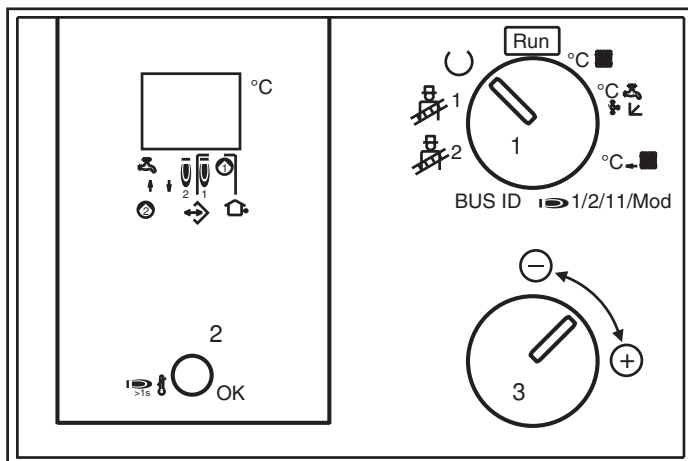

fig. 23

- 1**
 - 1) Switch selector to burner (1)
 - 2) Press OK (2)
 - 3) Turn the knob (3) until mm appears on the display (modulating burner)
 - 4) Press OK (2)
- 2**
 - 1) Switch the selector (1) to the symbol of the mixer valve
 - 2) Press OK (2)
 - 3) Turn the knob (3) until the number 15 appears on the display (burner servomotor time)
 - 4) Press OK (2)
- 3**
 - 1) Switch the selector (1) to BUS ID
 - 2) Press OK (2)
 - 3) Turn the knob (3) until the number 1 appears on the display (boiler ID)
 - 4) Press OK (2). Turn the knob 1 back to pos. RUN.

Installation instructions

3.18- HYDRAULIC AND ELECTRIC SYSTEM CONNECTION WITH PANEL BOARD code 37892

Fig. 24 shows the typical layout of the connection of the boiler to the heating system consisting in 1 direct high temperature zone + 1 low temperature zone controlled by a motorised mixer valve + domestic hot water production.

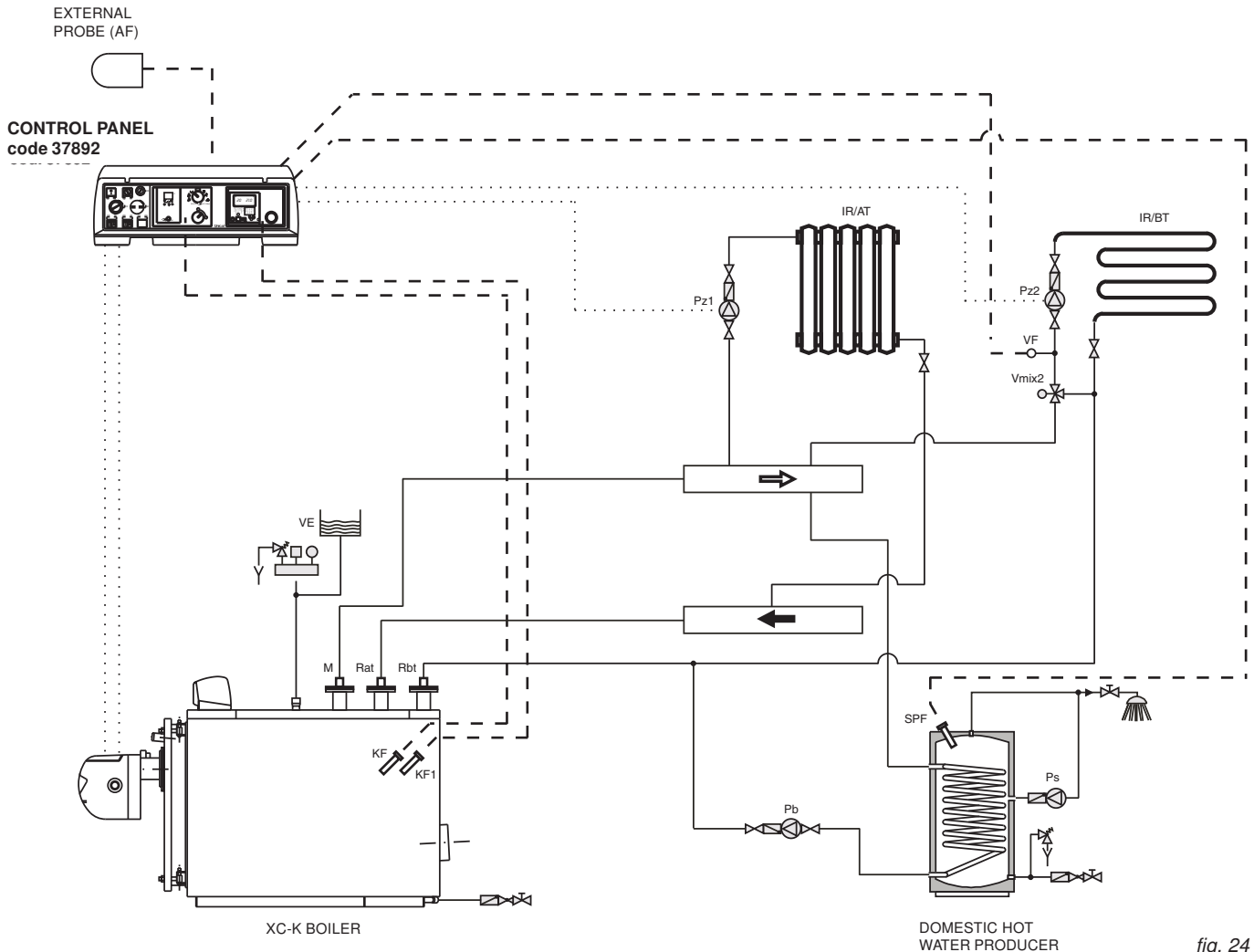

fig. 24

IMPORTANT NOTE: when there is only one zone (high or low temperature) always insert the system return pipe in the lower rear connection.

Key:

M = flow

Rat = HIGH temperature return

Rbt = LOW temperature return

Vmix2 = zone mixer valve (motorised)

Pz1 = HIGH TEMPERATURE zone heating system pump

Pz2 = LOW TEMPERATURE zone heating system pump

VE = expansion vessel

IR/AT = HIGH TEMPERATURE heating system distribution

IR/BT = LOW TEMPERATURE heating system distribution

Ps = DHW recirculation pump

Pb = DHW production charge pump

SPF = storage tank probe

KF = E8.5064 heat control boiler probe

KF 1= Lago Basic 0201 RV 1 heat control boiler probe

VF = flow probe

AF = external probe

For practical connections, both electrical and of the probes, see the diagrams supplied with the panel board code 37892.

The panel board of the XC-K boiler automatically switches the burner off when the temperature in the boiler reaches the value set on the heating controller.

It also manages the pump to fill a storage tank for DHW production.

The heating systems are managed automatically based on the data detected by the boiler, external, ambient and flow probes.

The high temperature zone system pump is made ready for operation by the control switch pos. 20, and will only switch off when the temperature set on the heating controller has been reached.

The low temperature zone system pump is made ready for operation by the control switch pos. 21, and will only switch off when the temperature set on the heating controller has been reached.

The storage tank charge pump for DHW production switches on automatically and will only switch off when the temperature set on the heating controller has been reached.

The panel is set up to manage the modulating burners.

With this system configuration, the heat controller is capable of regulating:

- direct zone system; the control unit commands the system pump. The room temperature is controlled by the programming curves set in the heating controller;
- one zone system with motorised mixer valve: the flow

probe (downstream the mixer valve) must be fitted; the control unit commands the system pump and the mixer valve. The room temperature is controlled by the programming curves set in the heating controller;

- DHW production through storage tank;
- anti-legionella function with increase of water temperature in storage tank (function not enabled in factory, but can be enabled by customer)

For practical connections, both electrical and of the probes, see the diagrams supplied with the panel board code 37892.

Installation instructions

3.19 - PROGRAMMING HEATING CONTROLLERS WITH BOILERS IN CASCADE

For that which concerns adjustment and programming of the heating modules, see the instruction booklets attached to the individual heating controller.

The following are the default parameters which “cannot be

modified”.

As far as parameters which can be programmed by the user according to his requirements, see the system manager instruction book.

PARAMETERS PROGRAMMABLE BY TECHNICIAN AND PROTECTED BY ACCESS CODE FOR HEATING CONTROLLER type E8.5064

INSTALLATION			
Description	Value range	Default	Individual values
CODE NUMBER	0000 - 9999	ENTRY	
CODE NUMBER (adjustment)	0000 - 9999	0000	
BOILER BUS ID, 01 - 08	----	
BUS ID 1	(00), 01 - 015	01	
BUS ID 2	(00), 01 - 016	02	
AF SUPPLY	00,01 (OFF/ON)	01 (ON)	
BUS CONNECTION	0,01	01	
BUS SUPPLY	00,01 (OFF/ON)	01 (ON)	
TEMPERATURE MASTER	00, 01 (OFF / ON)	01 (ON)	
MAX-T HS1 MAX T-HEADER	30 °C - 110 °C	85 °C	
MIN-T HS1 MIN T-HEADER	10 °C - 80 °C	10 °C	
MAX-T HS2	30 °C - 110 °C	85 °C	
MIN-T HS2	10 °C - 80 °C	10 °C	
VOLTAGE CURVE	0 - 11	11	
CURVE 11-U2	0,00-10,00V	0V	
CURVE 11-U2	0,00-10,00V	10V	
CURVE 11-T1	00 - 120 °C	0 °C	
CURVE 11-T2	00 - 120 °C	100 °C	
CURVE 11-UA	0,00-10,00V	0V	
T-WARM-UP	10 °C - 85 °C	10	
MINIMUM LIMIT	00, 01, 02	00	
HYSTERESIS	2K - 20K	5	
HYSTERESIS TIME	00 - 30 min	00 min	
BOILER DETECTED	DISPLAY ONLY		
OUTPUT LEVEL	00 - 1000kW	* see note	
NEW CONFIGURATION	00,01 (OFF/ON)		
MINIMUM MODULATION CASCADE	00 - 100	00	
DHW LEVELS	00 - 08	00	
CONTROL VARIANCE	(K)	DISPLAY	
NOMINAL OUTPUT INDEX	0 - 100%	DISPLAY	
SWITCH VALUE	(-99) - 0 - (99)	DISPLAY	
BLOCK TIME	REMAINING (min)	DISPLAY	
MAXIMUM BOILER TEMPERATURE	50 - 110 °C	85	
BOILER DYNAMICS UPWARD	20 - 500K	30K	

Installation instructions

Description	Value range	Default	Individual values
BOILER DYNAMICS DOWNWARD	20 - 500K	20K	
RESET TIME	5 - 500	50	
MODULATION MAX	0% - 100%	80%	
MODULATION MIN	0% - 100%	50%	
MIN MODULATION HS	0% - 100%	0%	
MODULATION DHW	40% - 100%	80%	
BOILER SEQUENCE 1	----	12345678	
BOILER SEQUENCE 2	----	87654321	
SEQUENCE MODE	01 - 06	01	
SEQUENCE CHANGE	10 - 800 HOURS	200 HOURS	
CYCLE BLOCK	00 min - 30 min	00 min	
HYSTERESIS BURNER 2	2K - 20K	2K	
BOILER COOLING FUNCTION	00 - 01	00	
BOILER COOLING TEMPERATURE	30°C - 120°C	95	
HS 1 TYPE	00 - 06	06	
HS 1 BUS	00 - 04	04	
HS 2 TYPE	00 - 05	00	
HS 2 STORAGE TANK	01 - 03	00	
BUFFER	01 - 01 - 02	00	
SCREED	00, 01 (OFF / ON)	00 OFF	
SCREED PROGRAM	** see note		

- * Set value of first stage of first boiler at 1, in the second leave dashes.
 Set value of first stage of second boiler at 1, in the second leave dashes.
 If there are more than 2 boilers in cascade, enable the first stages of the boilers in cascade.

** See E8.5064 heating controller instruction book

DOMESTIC HOT WATER PRODUCTION			
Description	Value range	Default	Individual values
CHARGE PUMP	00 - 01 (OFF / ON)	01 (ON)	
PARALLEL PUMP RUNNING	00 , 01, 02, 03	01	
T DHW	00K - 50K	20K	
DHW HYSTERESIS	5K - 30K	5 degrees	
DHW FOLLOWUP	00 min - 30 min	00 min	
THERMOSTAT INPUT	00, 01 (OFF / ON)	00 OFF	
THERMOSTAT FUNCTIONING	00, 01 (OFF / ON)	00 OFF	
LOAD THROUGH	00, 01 (OFF / ON)	00 OFF	
RETURN	Exit level using		

HEATING CIRCUIT 1			
Description	Value range	Default	Individual values
HEATING CIRCUIT FUNCTION	00 - 04	0	
PUMP MODE	00 - 03	0	
MIXER OPEN	5 - 25	----	
MIXER CLOSED	5 - 25	----	

Installation instructions

Description	Value range	Default	Individual values
MAX FLOW TEMPERATURE	20 °C - 110 °C	80 °C	
MIN FLOW TEMPERATURE	10 °C - 110 °C	30 °C	
FROST PROTECTION TEMP	(-15)°C - (5)°C	0 °C	
OUTSIDE TEMP DELAY	0:00 - 24:00	0.00	
HEATING SLOPE DISTANCE	00K - 50K	5 °C	
B-HEAT SINK	00 - 01 (OFF / ON)	01	
RETURN	Exit level using		

HEATING CIRCUIT 2			
Description	Value range	Default	Individual values
HEATING CIRCUIT FUNCTION	00 - 04	0	
PUMP MODE	00 - 03	0	
MIXER OPEN	5 - 25	18	
MIXER CLOSED	5 - 25	12	
MAX FLOW TEMPERATURE	20 °C - 110 °C	45 °C	
MIN FLOW TEMPERATURE	10 °C - 110 °C	10 °C	
FROST PROTECTION TEMP	(-15)°C - (5)°C	0 °C	
OUTSIDE TEMP DELAY	0:00 - 24:00	0.00	
HEATING SLOPE DISTANCE	00K - 50K	5 °C	
B-HEAT SINK	00 - 01 (OFF / ON)	01	
RETURN	Exit level using		

SOLAR M/F			
Description	Value range	Default	Individual values
MF (1-4) FUNCTION	00 - 26	00,00,01,02	
MF (1-4) T- NOM	00 - 03	30°C	
MF (1 - 4) HYSTERESIS	5 - 25	5°C	
F 15 FUNCTION	5 - 25	0	
RETURN	Exit level using		

PARAMETERS PROGRAMMABLE BY TECHNICIAN FOR HEATING CONTROLLER Lago Basic 0201 RV 1 ON BOILER N°1

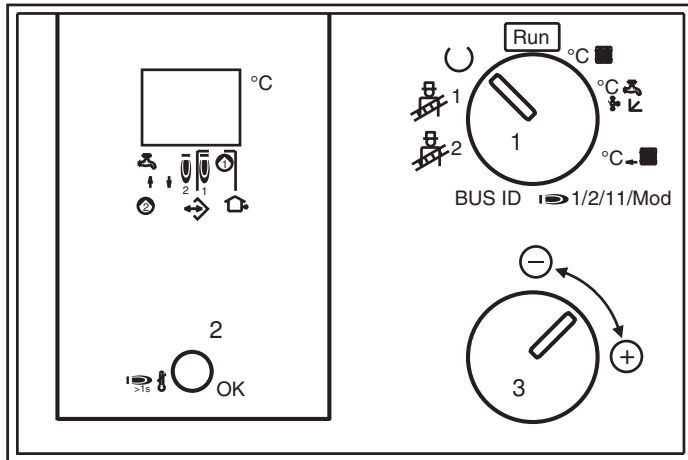

fig. 25

- 1**
 - 1) Switch selector to burner (1)
 - 2) Press OK (2)
 - 3) Turn the knob (3) until mm appears on the display
 - 4) Press OK (2)
- 2**
 - 1) Switch the selector (1) to the symbol of the mixer valve
 - 2) Press OK (2)
 - 3) Turn the knob (3) until the number 15 appears on the display (burner servomotor time)
 - 4) Press OK (2)
- 3**
 - 1) Switch the selector (1) to BUS ID
 - 2) Press OK (2)
 - 3) Turn the knob (3) until the number 1 appears on the display (boiler ID)
 - 4) Press OK (2). Turn the knob 1 back to RUN.

Installation instructions

3.20 - MODULATING CASCADE PANEL BOARD code 37900

The main switch 11 powers the board and the equipment connected to it.

The switches 12 and 13 control the burner and P1 pump if the boiler operates in cascade.

The working temperature of the boiler n°2 is regulated by the heating controller: to achieve this, the thermostat must be placed at maximum full-scale pos. 32

Modulation of the burner will be managed by heat control.

The electric power line of the boiler's control board must have a switch with protective fuses.

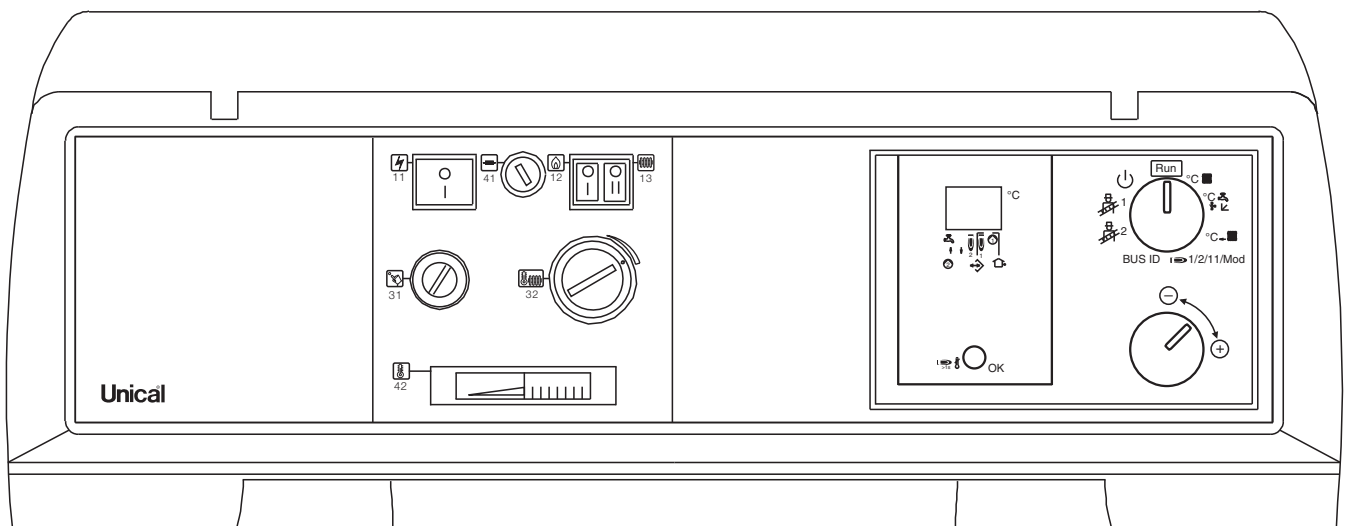

11 Main switch with indicator light
12 Burner switch
13 P1 system pump switch (cascade)
31 Safety thermostat

32 Working thermostat
41 General fuse
42 Thermometer

fig. 26

**For use of the panel board, see the system manager instruction booklet
As far as the practical connection and operating diagrams are concerned, see the
documentation supplied inside the panel board code 37900**

The boiler probe is included in the supply.

PARAMETERS PROGRAMMABLE BY TECHNICIAN FOR HEATING CONTROLLER Lago Basic 0201 RV 1 ON BOILER N°2

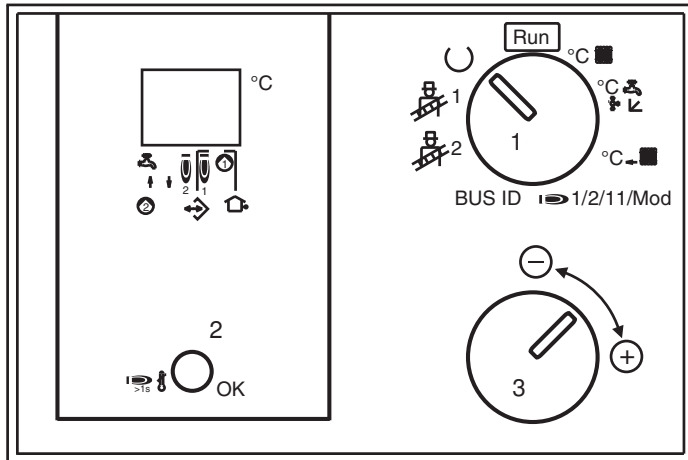

fig. 27

- 1**
 - 1) Switch selector to burner (1)
 - 2) Press OK (2)
 - 3) Turn the knob (3) until mm appears on the display
 - 4) Press OK (2)
- 2**
 - 1) Switch the selector (1) to the symbol of the mixer valve
 - 2) Press OK (2)
 - 3) Turn the knob (3) until the number 15 appears on the display (burner servomotor time)
 - 4) Press OK (2)
- 3**
 - 1) Switch the selector (1) to BUS ID
 - 2) Press OK (2)
 - 3) Turn the knob (3) until the number 2 appears on the display (boiler ID)
 - 4) Press OK (2). Turn the knob 1 back to RUN.

3.21 - HYDRAULIC AND ELECTRIC SYSTEM CONNECTION WITH BOILERS IN CASCADE PANEL BOARD code 37892 and code 37900

Fig. 28 shows the typical layout of the connection of the boiler to the heating system consisting in 2 boilers in cascade serving 1 high temperature zone + 1 low temperature zone controlled by a motorised mixer valve + domestic hot water production.

Boiler n° 1 is fitted with a panel board code 37892, boiler n° 2 is fitted with a panel board code 37900.

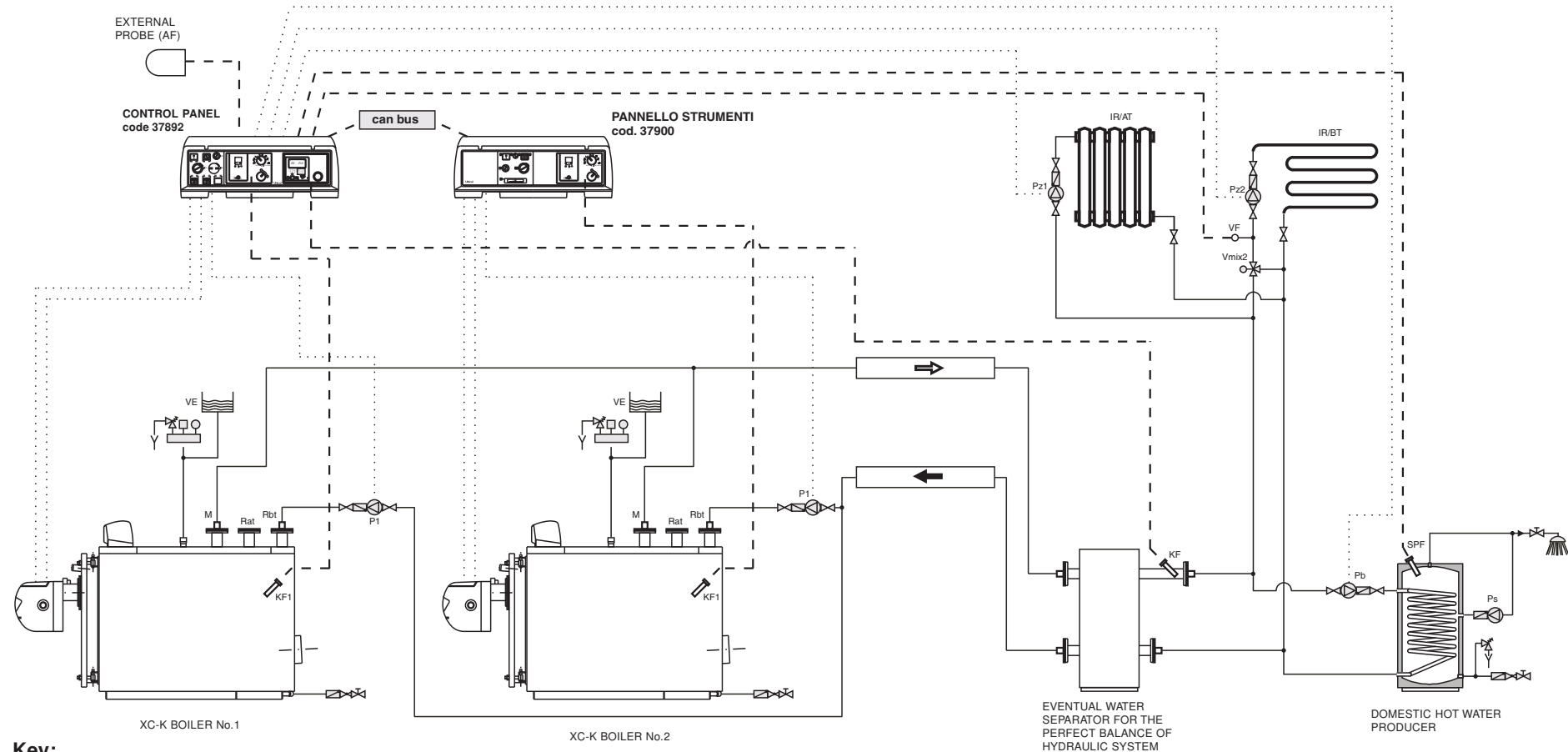

Key:

M = flow
Rat = HIGH temperature return (NOT USED)
Rbt = LOW temperature return
Vmix2 = zone mixer valve (motorised)
Pz1 = HIGH TEMPERATURE zone heating system pump
Pz2 = LOW TEMPERATURE zone heating system pump
VE = expansion vessel
IR/AT = HIGH TEMPERATURE heating system distribution
IR/BT = LOW TEMPERATURE heating system distribution

Ps = DHW recirculation pump
P1 = circulation pump
Pb = DHW production charge pump
SPF = storage tank probe
KF = E8.5064 heat control boiler probe
KF 1 = Lago Basic 0201 RV 1 heat control boiler probe
VF = flow probe
AF = external probe

fig. 28

Installation instructions

The panel boards of the XC-K boilers (in cascade) automatically switch the burners off when the temperature in the boiler reaches the value set on the heating controller.

They also manage the pump to fill a storage tank for DHW production.

The heating systems are managed automatically based on the data detected by the boiler, external, ambient and flow probes.

The high temperature zone system pump is made ready for operation by the control switch pos. 20 of the MASTER board, and will only switch off when the temperature set on the heating controller has been reached.

The low temperature zone system pump is made ready for operation by the control switch pos. 21 of the MASTER board, and will only switch off when the temperature set on the heating controller has been reached.

The storage tank charge pump for DHW production switches on automatically and will only switch off when the temperature set on the heating controller has been reached.

The panel is set up to manage the modulating burners.

With this system configuration, the heat controller is capable of regulating:

- direct zone system; the control unit commands the

system pump. The room temperature is controlled by the programming curves set in the heating controller;

- one zone system with motorised mixer valve: the flow probe (downstream the mixer valve) must be fitted; the control unit commands the system pump and the mixer valve. The room temperature is controlled by the programming curves set in the heating controller;
- DHW production through storage tank;
- anti-legionella function with increase of water temperature in storage tank (function not enabled in factory, but can be enabled by customer)

For practical connections, both electrical and of the probes, see the diagrams supplied with the panel boards code 37892 and 37900).

Installation instructions

3.22 - DUAL-STAGE MASTER PANEL BOARD code 38778

The main switch [14] powers the board and the equipment connected to it.

The switches [18] and [19] control the burner and P1 pump if the boiler operates in cascade.

The switches [20] and [21] control the Z1 pump (direct) and Z2 pump (mixed).

The working temperature of the boiler is regulated by the heating controller: to achieve this, the thermostat must be placed at maximum full-scale pos. [33].

Modulation of the burner will be managed by heat control.

The electric power line of the boiler's control board must have a switch with protective fuses.

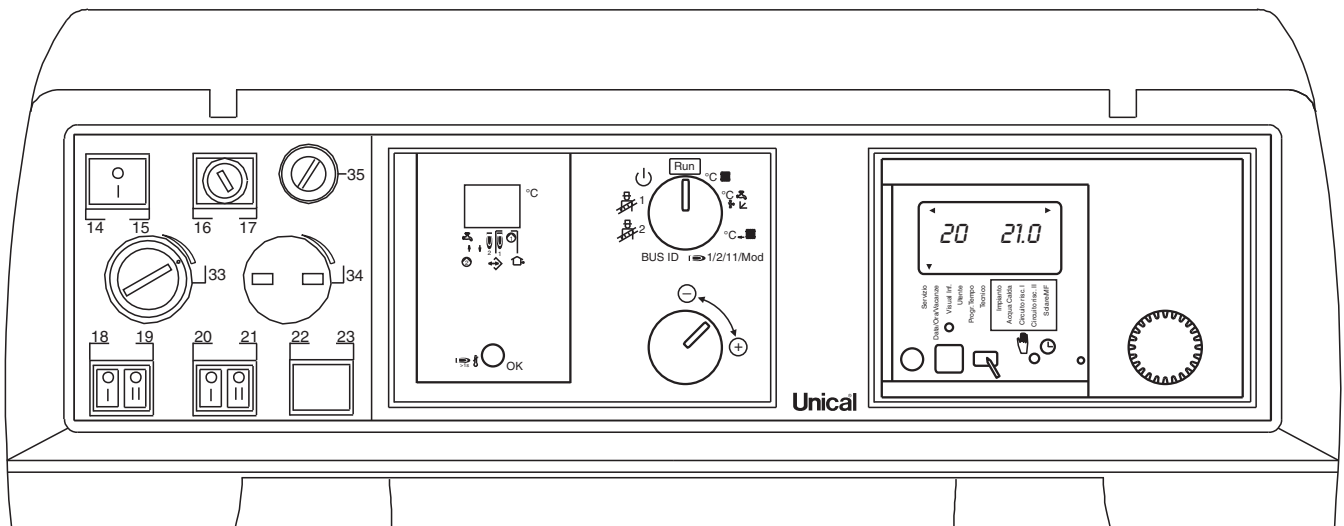

fig. 29

14 Main switch with indicator light

16 General fuse

18 Burner switch

19 P1 system pump switch (cascade)

20 Pz1 direct zone system pump switch

21 Pz2 mixed zone system pump switch

33 Working thermostat

35 Safety thermostat

For use of the panel board, see the system manager instruction booklet

As far as the practical connection and operating diagrams are concerned, see the documentation supplied inside the panel board code 38778

The heating controller probes (boiler, storage tank, external, flow) are included in the supply; the ambient probes 1 and 2 are optional; the mixer valve and relative control motor are not included in the supply.

Should ambient probes be mounted (optional), the room tem-

perature will only be determined with the boiler curve set by the program.

Should 2 boilers in cascade be mounted, see chapters 3.25, 3.26, 3.27.

3.23 - PROGRAMMING HEATING CONTROLLERS WITH SINGLE BOILER

For that which concerns adjustment and programming of the heating modules, see the instruction booklets attached to the individual heating controller.

The following are the default parameters which "cannot be

modified".

As far as parameters which can be programmed by the user according to his requirements, see the system manager instruction book.

PARAMETERS PROGRAMMABLE BY TECHNICIAN AND PROTECTED BY ACCESS CODE FOR HEATING CONTROLLER type E8.5064

INSTALLATION			
Description	Value range	Default	Individual values
CODE NUMBER	0000 - 9999	ENTRY	
CODE NUMBER (adjustment)	0000 - 9999	0000	
BOILER BUS ID, 01 - 08	----	
BUS ID 1	(00), 01 - 015	01	
BUS ID 2	(00), 01 - 016	02	
AF SUPPLY	00,01 (disins/ins)	01 (ON)	
BUS CONNECTION	0,01	01	
BUS SUPPLY	00,01 (disins/ins)	01 (ON)	
TEMPERATURE MASTER	00, 01 (OFF / ON)	01 (ON)	
MAX-T HS1 MAX T-HEADER	30 °C - 110 °C	85 °C	
MIN-T HS1 MIN T-HEADER	10 °C - 80 °C	10 °C	
MAX-T HS2	30 °C - 110 °C	85 °C	
MIN-T HS2	10 °C - 80 °C	10 °C	
VOLTAGE CURVE	0 - 11	11	
CURVE 11-U2	0,00-10,00V	0V	
CURVE 11-U2	0,00-10,00V	10V	
CURVE 11-T1	00 - 120 °C	0 °C	
CURVE 11-T2	00 - 120 °C	100 °C	
CURVE 11-UA	0,00-10,00V	0V	
T-WARM-UP	10 °C - 85 °C	10	
MINIMUM LIMIT	00, 01, 02	00	
HYSTERESIS	2K - 20K	5	
HYSTERESIS TIME	00 - 30 min	00 min	
BOILER DETECTED	DISPLAY ONLY		
OUTPUT LEVEL	00 - 1000kW	* see note	
NEW CONFIGURATION	00,01 (disins/ins)		
MINIMUM MODULATION CASCADE	00 - 100	00	
DHW LEVELS	00 - 08	00	
CONTROL VARIANCE	(K)	DISPLAY	
NOMINAL OUTPUT INDEX	0 - 100%	DISPLAY	
SWITCH VALUE	(-99) - 0 - (99)	DISPLAY	
BLOCK TIME	REMAINING (min)	DISPLAY	
MAXIMUM BOILER TEMPERATURE	50 - 110 °C	85	
BOILER DYNAMICS UPWARD	20 - 500K	30K	
BOILER DYNAMICS DOWNWARD	20 - 500K	20K	
RESET TIME	5 - 500	50	
MODULATION MAX	0% - 100%	80%	
MODULATION MIN	0% - 100%	50%	
MIN MODULATION HS	0% - 100%	0%	
MODULATION DHW	40% - 100%	80%	
BOILER SEQUENCE 1	----	12345678	
BOILER SEQUENCE 2	----	87654321	

Installation instructions

Description	Value range	Default	Individual values
SEQUENCE MODE	01 - 06	01	
SEQUENCE CHANGE	10 - 800 HOURS	200 HOURS	
CYCLE BLOCK	00 min - 30 min	00 min	
HYSTERESIS BURNER 2	2K - 20K	2K	
BOILER COOLING FUNCTION	00 - 01	00	
BOILER COOLING TEMPERATURE	30°C - 120°C	95	
HS 1 TYPE	00 - 06	05	
HS 1 BUS	00 - 04	04	
HS 2 TYPE	00 - 05	00	
HS 2 STORAGE TANK	01 - 03	00	
BUFFER	01 - 01 - 02	00	
SCREED	00, 01 (OFF - ON)	00 OFF	
SCREED PROGRAM	** see note		

* Set value of first stage of first boiler at 1, in the second leave dashes.
All other boiler stages must be disabled.

** See E8.5064 heating controller instruction book

DOMESTIC HOT WATER PRODUCTION			
Description	Value range	Default	Individual values
CHARGE PUMP	00 - 01 (OFF / ON)	01 (ON)	
PARALLEL PUMP RUNNING	00 , 01, 02, 03	01	
T DHW	00K - 50K	20K	
DHW HYSTERESIS	5K - 30K	5 degrees	
DHW FOLLOWUP	00 min - 30 min	00 min	
THERMOSTAT INPUT	00, 01 (OFF / ON)	00 OFF	
THERMOSTAT FUNCTIONING	00, 01 (OFF / ON)	00 OFF	
LOAD THROUGH	00, 01 (OFF / ON)	00 OFF	
RETURN	Exit level using		

HEATING CIRCUIT 1			
Description	Value range	Default	Individual values
HEATING CIRCUIT FUNCTION	00 - 04	0	
PUMP MODE	00 - 03	0	
MIXER OPEN	5 - 25	----	
MIXER CLOSED	5 - 25	----	
MAX FLOW TEMPERATURE	20 °C - 110 °C	80 °C	
MIN FLOW TEMPERATURE	10 °C - 110 °C	30 °C	
FROST PROTECTION TEMP	(-15)°C - (5)°C	0 °C	
OUTSIDE TEMP DELAY	0:00 - 24:00	0.00	
HEATING SLOPE DISTANCE	00K - 50K	5 °C	
B-HEAT SINK	00 - 01 (OFF / ON)	01	
RETURN	Exit level using		

HEATING CIRCUIT 2			
Description	Value range	Default	Individual values
HEATING CIRCUIT FUNCTION	00 - 04	0	
PUMP MODE	00 - 03	0	
MIXER OPEN	5 - 25	----	
MIXER CLOSED	5 - 25	----	
MAX FLOW TEMPERATURE	20 °C - 110 °C	45 °C	
MIN FLOW TEMPERATURE	10 °C - 110 °C	10 °C	
FROST PROTECTION TEMP	(-15)°C - (5)°C	0 °C	
OUTSIDE TEMP DELAY	0:00 - 24:00	0.00	
HEATING SLOPE DISTANCE	00K - 50K	5 °C	
B-HEAT SINK	00 - 01 (OFF / ON)	01	
RETURN	Exit level using 		

SOLAR M/F			
Description	Value range	Default	Individual values
MF (1-4) FUNCTION	00 - 26	00,00,01,02	
MF (1-4) T- NOM	00 - 03	30 °C	
MF (1 - 4) HYSTERESIS	5 - 25	5 °C	
F 15 FUNCTION	5 - 25	0	
RETURN	Exit level using 		

PARAMETERS PROGRAMMABLE BY TECHNICIAN FOR HEATING CONTROLLER

Lago Basic 0201 RV 1

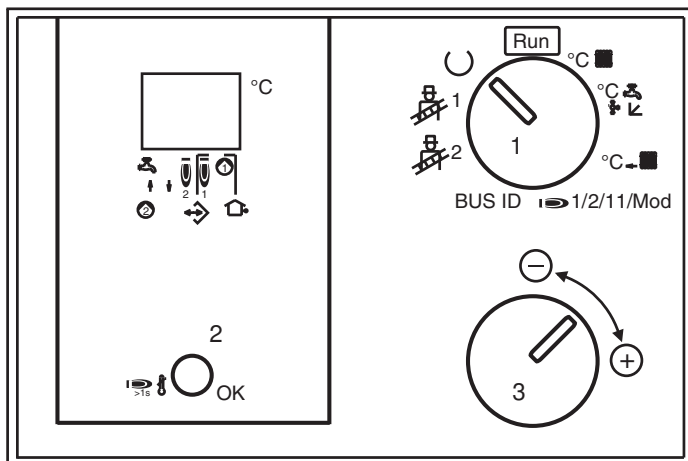

fig. 30

- 1**
 - 1) Switch selector to burner (1)
 - 2) Press OK (2)
 - 3) Turn the knob (3) until 2 appears on the display (dual-stage burner)
 - 4) Press OK (2)
- 2**
 - 1) Switch the selector (1) to the symbol of the mixer valve
 - 2) Press OK (2)
 - 3) Turn the knob (3) until the number 15 appears on the display
 - 4) Press OK (2)
- 3**
 - 1) Switch the selector (1) to BUS ID
 - 2) Press OK (2)
 - 3) Turn the knob (3) until the number 1 appears on the display (boiler ID)
 - 4) Press OK (2). Turn the knob 1 back to pos. RUN.

Installation instructions

3.24- HYDRAULIC AND ELECTRIC SYSTEM CONNECTION WITH PANEL BOARD code 38778

Fig. 31 shows the typical layout of the connection of the boiler to the heating system consisting in 1 direct high temperature zone + 1 low temperature zone controlled by a motorised mixer valve + domestic hot water production.

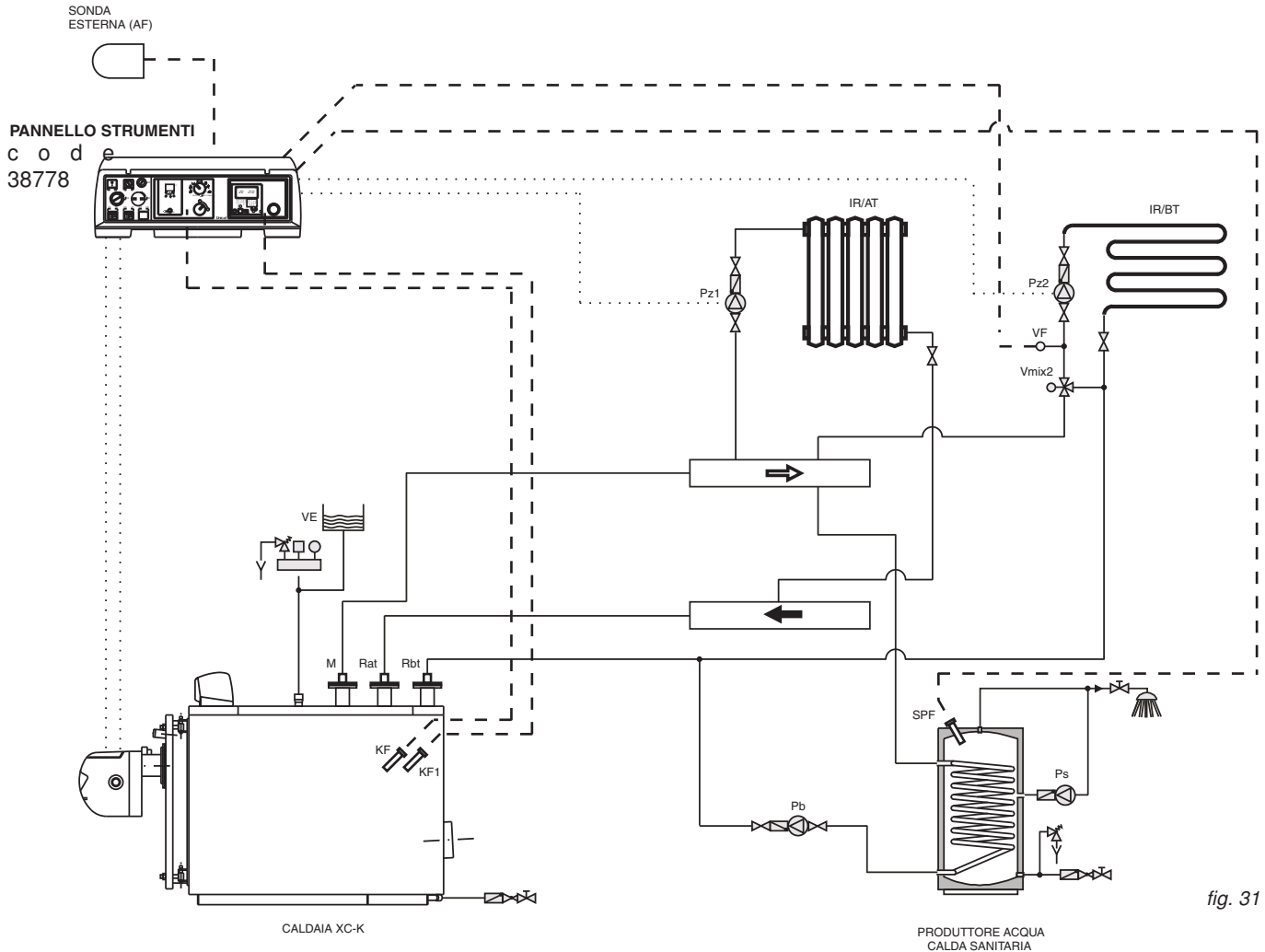

fig. 31

IMPORTANT NOTE: when there is only one zone (high or low temperature) always insert the system return pipe in the lower rear connection.

Key:

- Vmix2* = zone mixer valve (motorised)
- Pz1* = HIGH TEMPERATURE zone heating system pump
- Pz2* = LOW TEMPERATURE zone heating system pump
- VE* = expansion vessel
- IR/AT* = HIGH TEMPERATURE heating system distribution
- IR/BT* = LOW TEMPERATURE heating system distribution
- Ps* = DHW recirculation pump
- Pb* = DHW production charge pump
- SPF* = storage tank probe
- KF* = E8.5064 heat control boiler probe
- KF 1* = Lago Basic 0201 RV 1 heat control boiler probe
- VF* = flow probe
- AF* = external probe

For practical connections, both electrical and of the probes, see the diagrams supplied with the panel boards code 38778.

The panel board of the XC-K boiler automatically switches the burner off when the temperature in the boiler reaches the value set on the heating controller.

It also manages the pump to fill a storage tank for DHW production.

The heating systems are managed automatically based on the data detected by the boiler, external, ambient and flow probes.

The high temperature zone system pump is made ready for operation by the control switch pos. 20, and will only switch off when the temperature set on the heating controller has been reached.

The low temperature zone system pump is made ready for operation by the control switch pos. 21, and will only switch off when the temperature set on the heating controller has been reached.

The storage tank charge pump for DHW production switches on automatically and will only switch off when the temperature set on the heating controller has been reached.

The panel is set up to manage the modulating burners.

With this system configuration, the heat controller is capable of regulating:

- direct zone system; the control unit commands the system pump. The room temperature is controlled by the programming curves set in the heating controller;
- one zone system with motorised mixer valve: the flow probe (downstream the mixer valve) must be fitted; the control unit commands the system pump and the mixer valve. The room temperature is controlled by the

programming curves set in the heating controller;

- DHW production through storage tank;
- anti-legionella function with increase of water temperature in storage tank (function not enabled in factory, but can be enabled by customer)

For practical connections, both electrical and of the probes, see the diagrams supplied with the panel boards code 38778.

Installation instructions

3.25 - PROGRAMMING HEATING CONTROLLERS WITH BOILER IN CASCADE

For that which concerns adjustment and programming of the heating modules, see the instruction booklets attached to the individual heating controller.

The following are the default parameters which “cannot be

modified”.

As far as parameters which can be programmed by the user according to his requirements, see the system manager instruction book.

PARAMETERS PROGRAMMABLE BY TECHNICIAN AND PROTECTED BY ACCESS CODE FOR HEATING CONTROLLER type E8.5064

INSTALLATION			
Description	Value range	Default	Individual values
CODE NUMBER	0000 - 9999	ENTRY	
CODE NUMBER (adjustment)	0000 - 9999	0000	
BOILER BUS ID, 01 - 08	----	
BUS ID 1	(00), 01 - 015	01	
BUS ID 2	(00), 01 - 016	02	
AF SUPPLY	00,01 (disins/ins)	01 (ON)	
BUS CONNECTION	0,01	01	
BUS SUPPLY	00,01 (disins/ins)	01 (ON)	
TEMPERATURE MASTER	00, 01 (OFF / ON)	01 (ON)	
MAX-T HS1 MAX T-HEADER	30 °C - 110 °C	85 °C	
MIN-T HS1 MIN T-HEADER	10 °C - 80 °C	10 °C	
MAX-T HS2	30 °C - 110 °C	85 °C	
MIN-T HS2	10 °C - 80 °C	10 °C	
VOLTAGE CURVE	0 - 11	11	
CURVE 11-U2	0,00-10,00V	0V	
CURVE 11-U2	0,00-10,00V	10V	
CURVE 11-T1	00 - 120 °C	0 °C	
CURVE 11-T2	00 - 120 °C	100 °C	
CURVE 11-UA	0,00-10,00V	0V	
T-WARM-UP	10 °C - 85 °C	10	
MINIMUM LIMIT	00, 01, 02	00	
HYSTERESIS	2K - 20K	5	
HYSTERESIS TIME	00 - 30 min	00 min	
BOILER DETECTED	DISPLAY ONLY		
OUTPUT LEVEL	00 - 100kW	* see note	
NEW CONFIGURATION	00,01 (disins/ins)		
MINIMUM MODULATION CASCADE	00 - 100	00	
DHW LEVELS	00 - 08	00	
CONTROL VARIANCE	(K)	DISPLAY	
NOMINAL OUTPUT INDEX	0 - 100%	DISPLAY	
SWITCH VALUE	(-99) - 0 - (99)	DISPLAY	
BLOCK TIME	REMAINING (min)	DISPLAY	
MAXIMUM BOILER TEMPERATURE	50 - 110 °C	85	
BOILER DYNAMICS UPWARD	20 - 500K	30K	

Installation instructions

Description	Value range	Default	Individual values
BOILER DYNAMICS DOWNWARD	20 - 500K	20K	
RESET TIME	5 - 500	50	
MODULATION MAX	0% - 100%	80%	
MODULATION MIN	0% - 100%	50%	
MIN MODULATION HS	0% - 100%	0%	
MODULATION DHW	40% - 100%	80%	
BOILER SEQUENCE 1	----	12345678	
BOILER SEQUENCE 2	----	87654321	
SEQUENCE MODE	01 - 06	01	
SEQUENCE CHANGE	10 - 800 HOURS	200 HOURS	
CYCLE BLOCK	00 min - 30 min	00 min	
HYSTERESIS BURNER 2	2K - 20K	2K	
BOILER COOLING FUNCTION	00 - 01	00	
BOILER COOLING TEMPERATURE	30°C - 120°C	95	
HS 1 TYPE	00 - 06	05	
HS 1 BUS	00 - 04	04	
HS 2 TYPE	00 - 05	00	
HS 2 STORAGE TANK	01 - 03	00	
BUFFER	01 - 01 - 02	00	
SCREED	00, 01 (OFF - ON)	00 OFF	
SCREED PROGRAM	** see note		

- * Set the value of the first stage and second stage of the first boiler at 1.
 Set the value of the first stage and second stage of the second boiler at 1.
 If there are more than 2 boilers in cascade, enable the first and second stages of the boilers in cascade.

** See E8.5064 heating controller instruction book

DOMESTIC HOT WATER PRODUCTION			
Description	Value range	Default	Individual values
CHARGE PUMP	00 - 01 (OFF / ON)	01 (ON)	
PARALLEL PUMP RUNNING	00 , 01, 02, 03	01	
T DHW	00K - 50K	20K	
DHW HYSTERESIS	5K - 30K	5 degrees	
DHW FOLLOWUP	00 min - 30 min	00 min	
THERMOSTAT INPUT	00, 01 (OFF / ON)	00 OFF	
THERMOSTAT FUNCTIONING	00, 01 (OFF / ON)	00 OFF	
LOAD THROUGH	00, 01 (OFF / ON)	00 OFF	
RETURN	Exit level using		

HEATING CIRCUIT 1			
Description	Value range	Default	Individual values
HEATING CIRCUIT FUNCTION	00 - 04	0	
PUMP MODE	00 - 03	0	
MIXER OPEN	5 - 25	----	
MIXER CLOSED	5 - 25	----	

Installation instructions

Description	Value range	Default	Individual values
MAX FLOW TEMPERATURE	20 °C - 110 °C	80 °C	
MIN FLOW TEMPERATURE	10 °C - 110 °C	30 °C	
FROST PROTECTION TEMP	(-15)°C - (5)°C	0 °C	
OUTSIDE TEMP DELAY	0:00 - 24:00	0.00	
HEATING SLOPE DISTANCE	00K - 50K	5 °C	
B-HEAT SINK	00 - 01 (OFF / ON)	01	
RETURN	Exit level using		

HEATING CIRCUIT 2			
Description	Value range	Default	Individual values
HEATING CIRCUIT FUNCTION	00 - 04	0	
PUMP MODE	00 - 03	0	
MIXER OPEN	5 - 25	18	
MIXER CLOSED	5 - 25	12	
MAX FLOW TEMPERATURE	20 °C - 110 °C	45 °C	
MIN FLOW TEMPERATURE	10 °C - 110 °C	10 °C	
FROST PROTECTION TEMP	(-15)°C - (5)°C	0 °C	
OUTSIDE TEMP DELAY	0:00 - 24:00	0.00	
HEATING SLOPE DISTANCE	00K - 50K	5 °C	
B-HEAT SINK	00 - 01 (OFF / ON)	01	
RETURN	Exit level using		

SOLAR M/F			
Description	Value range	Default	Individual values
MF (1-4) FUNCTION	00 - 26	00,00,01,02	
MF (1-4) T- NOM	00 - 03	30°C	
MF (1 - 4) HYSTERESIS	5 - 25	5°C	
F 15 FUNCTION	5 - 25	0	
RETURN	Exit level using		

PARAMETERS PROGRAMMABLE BY TECHNICIAN FOR HEATING CONTROLLER Lago Basic 0201 RV 1 ON BOILER N°1

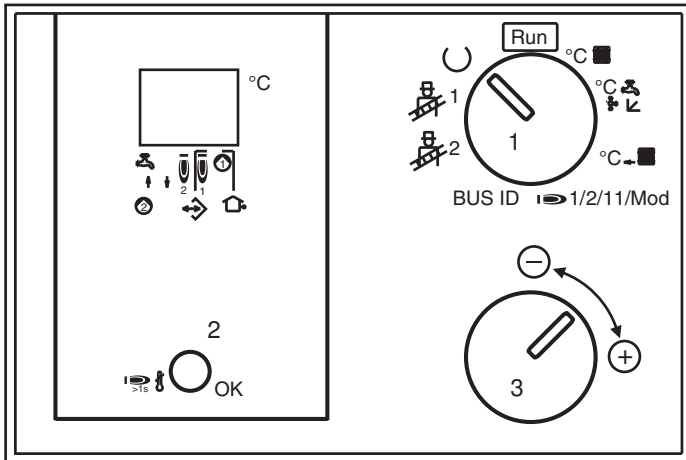

fig. 32

- 1**
 - 1) Switch selector to burner (1)
 - 2) Press OK (2)
 - 3) Turn the knob (3) until mm appears on the display
 - 4) Press OK (2)
- 2**
 - 1) Switch the selector (1) to the symbol of the mixer valve
 - 2) Press OK (2)
 - 3) Turn the knob (3) until the number 15 appears on the display (burner servomotor time)
 - 4) Press OK (2)
- 3**
 - 1) Switch the selector (1) to BUS ID
 - 2) Press OK (2)
 - 3) Turn the knob (3) until the number 1 appears on the display (boiler ID)
 - 4) Press OK (2). Turn the knob 1 back to RUN.

Installation instructions

3.25 - DUAL-STAGE CASCADE PANEL BOARD code 37901

The main switch [11] powers the board and the equipment connected to it.

The switches [12] and [13] control the burner and P1 pump if the boiler operates in cascade.

The working temperature of the boiler n°2 is regulated by the heating controller: to achieve this, the thermostat must be placed at maximum full-scale pos. [32].

Modulation of the burner will be managed by heat control.

The electric power line of the boiler's control board must have a switch with protective fuses.

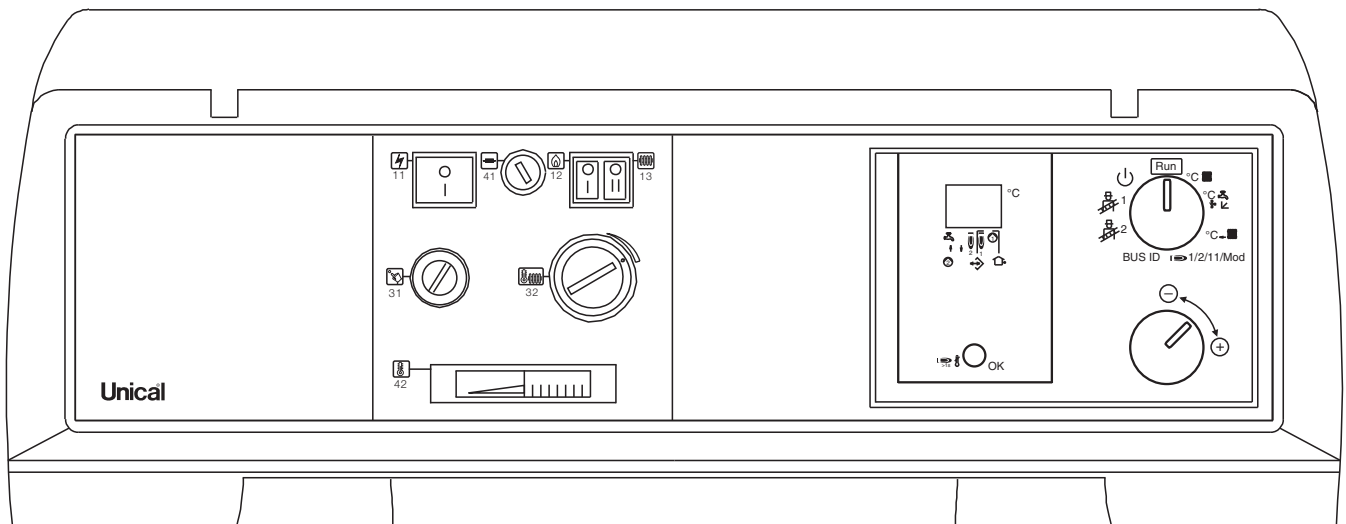

11 Main switch with indicator light
12 Burner switch
13 P1 system pump switch (cascade)
31 Safety thermostat

32 Working thermostat
41 General fuse
42 Thermometer

fig. 33

**For use of the panel board, see the system manager instruction booklet
As far as the practical connection and operating diagrams are concerned, see the
documentation supplied inside the panel board code 37901**

The boiler probe is included in the supply.

PARAMETERS PROGRAMMABLE BY TECHNICIAN FOR HEATING CONTROLLER Lago Basic 0201 RV 1 ON BOILER N°2

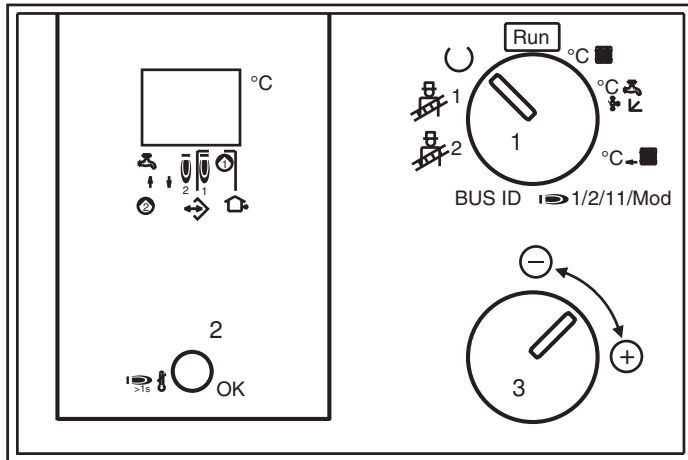

fig. 34

- 1**
 - 1) Switch selector to burner (1)
 - 2) Press OK (2)
 - 3) Turn the knob (3) until 2 appears on the display (dual-stage burner)
 - 4) Press OK (2)
- 2**
 - 1) Switch the selector (1) to the symbol of the mixer valve
 - 2) Press OK (2)
 - 3) Turn the knob (3) until the number 15 appears on the display
 - 4) Press OK (2)
- 3**
 - 1) Switch the selector (1) to BUS ID
 - 2) Press OK (2)
 - 3) Turn the knob (3) until the number 2 appears on the display (boiler ID)
 - 4) Press OK (2). Turn the knob 1 back to RUN.

3.27- HYDRAULIC AND ELECTRIC SYSTEM CONNECTION WITH BOILERS IN CASCADE PANEL BOARD code 38778 and code 37901

Fig. 35 shows the typical layout of the connection of the boiler to the heating system consisting in 2 boilers in cascade serving 1 high temperature zone + 1 low temperature zone controlled by a motorised mixer valve + domestic hot water production.

Boiler n° 1 is fitted with a panel board code 37892, boiler n° 2 is fitted with a panel board code 37900.

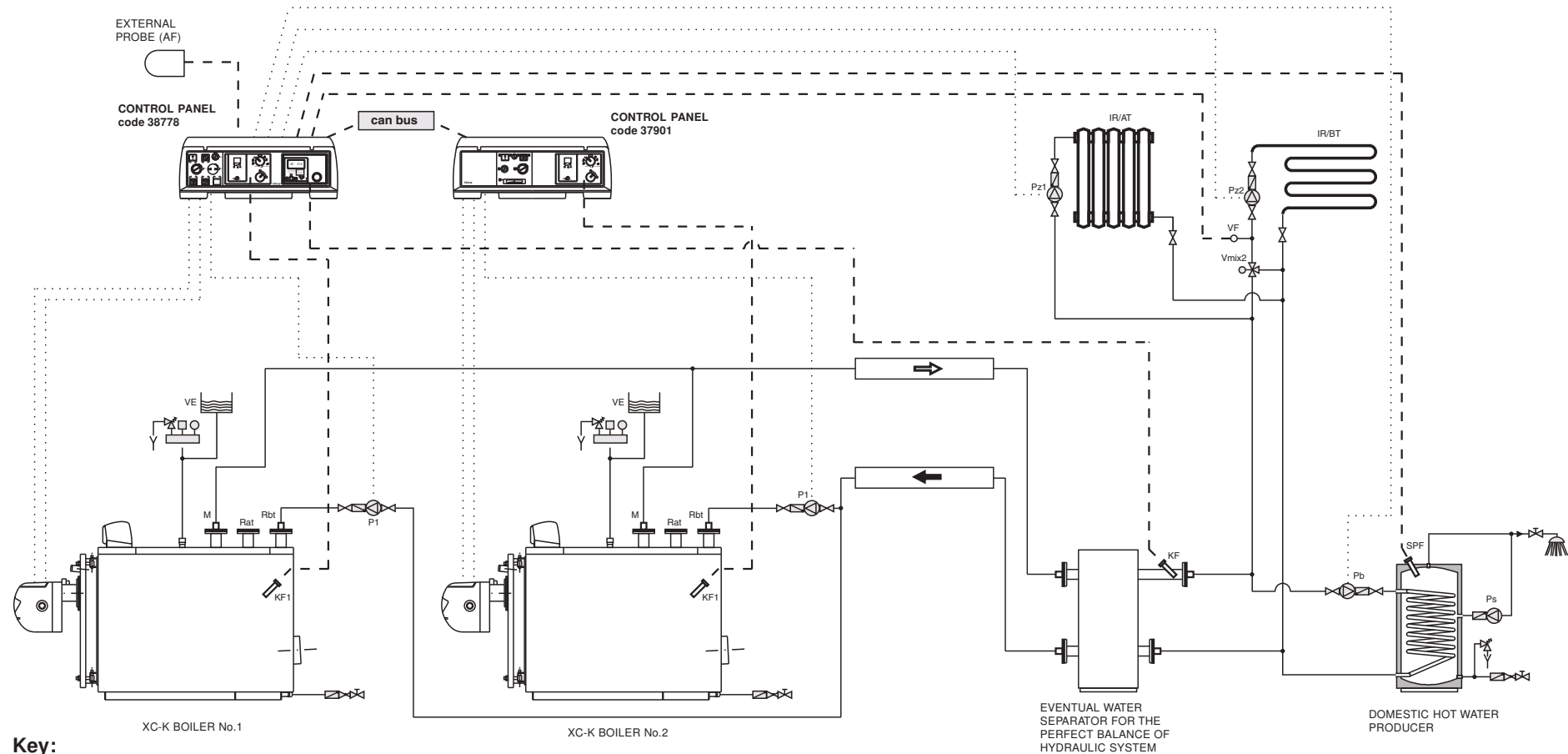

Key:

M = flow
Rat = HIGH temperature return (NOT USED)
Rbt = LOW temperature return
Vmix2 = zone mixer valve (motorised)
Pz1 = HIGH TEMPERATURE zone heating system pump
Pz2 = LOW TEMPERATURE zone heating system pump
VE = expansion vessel
IR/AT = HIGH TEMPERATURE heating system distribution
IR/BT = LOW TEMPERATURE heating system distribution

Ps = DHW recirculation pump
P1 = circulation pump
Pb = DHW production charge pump
SPF = storage tank probe
KF = E8.5064 heat control boiler probe
KF 1 = Lago Basic 0201 RV 1 heat control boiler probe
VF = flow probe
AF = external probe

fig. 35

The panel boards of the XC-K boilers (in cascade) automatically switch the burners off when the temperature in the boiler reaches the value set on the heating controller.

They also manage the pump to fill a storage tank for DHW production.

The heating systems are managed automatically based on the data detected by the boiler, external, ambient and flow probes.

The high temperature zone system pump is made ready for operation by the control switch pos. 20 of the MASTER board, and will only switch off when the temperature set on the heating controller has been reached.

The low temperature zone system pump is made ready for operation by the control switch pos. 21 of the MASTER board, and will only switch off when the temperature set on the heating controller has been reached.

The storage tank charge pump for DHW production switches on automatically and will only switch off when the temperature set on the heating controller has been reached.

The panel is set up to manage the modulating burners.

With this system configuration, the heat controller is capable of regulating:

- direct zone system; the control unit commands the system pump. The room temperature is controlled by the programming curves set in the heating controller;
- one zone system with motorised mixer valve: the flow

probe (downstream the mixer valve) must be fitted; the control unit commands the system pump and the mixer valve. The room temperature is controlled by the programming curves set in the heating controller;

- DHW production through storage tank;
- anti-legionella function with increase of water temperature in storage tank (function not enabled in factory, but can be enabled by customer)

For practical connections, both electrical and of the probes, see the diagrams supplied with the panel boards code 38778 and 37901.

3.28- COMMISSIONING

Preliminary checks



Commissioning must be done by professionally qualified personnel. Unical will not be held liable for damage to persons, animals or objects due to failure to comply with the instruction above.

Before commissioning the boiler, check that:

- installation complies with standards for the gas and electrical power;
- the adduction of combustion air and flue gas evacuation are performed correctly according to that laid down by standards in force;
- the fuel feed system is dimensioned according to the flow rate required for the boiler and is provided with all safety and control systems prescribed by current standards;
- the power supply of the boiler is 230V - 50Hz;
- the system is filled with water (approximately 1 bar pressure on the pressure gauge with the pump stopped);
- any system shut-off gate valves are open;
- the gas used corresponds to boiler calibration: if not, modify the boiler to use type of gas available; this operation must be carried out by qualified technical personnel according to standards in force;
- the gas feed valves are open;
- there is no gas leakage;
- the external main switch is connected;
- the system safety valves are not blocked and are connected to the sewer system drainage;
- there is no water leakage;
- ventilation conditions and minimum distances are guaranteed to perform maintenance should the boiler be enclosed between furniture or in a niche.

Switching boiler on and off

To switch the boiler on and off, see the “SYSTEM MANAGER OPERATING INSTRUCTIONS”.

Information for system manager

The system manager must be instructed concerning the use and operation of his heating system, in particular:

- Give the system manager the “SYSTEM MANAGER OPERATING INSTRUCTIONS”, as well as the other appliance documents inserted in the envelope inside the packaging. **The system manager must keep this documentation for future consultation.**
- Inform the system manager about the importance of the air vents and the flue gas exhaust system, highlighting their essential features and the absolute prohibition of modifying them.
- Inform the system manager concerning control of the system’s water pressure as well as operations to restore it.
- Inform the system manager concerning correct control of temperatures, control units/thermostats and radiators to save energy.
- Remember that the system must receive regular maintenance at least once a year and a combustion analysis must be performed in the timetable foreseen by standards in force.
- Should the appliance be sold or transferred to a new owner or if you move and leave the appliance, always make sure that the instruction booklet accompanies it in order to be consulted by the new owner and/or installer.

XC-K boilers are forced circulation boilers: It is therefore necessary to make sure that water circulates while the boiler is running.

Do not allow the burner to run without the system pump being activated; otherwise the safety thermostat could be triggered. Room temperature will be regulated by the mixture valve commanded by the heating controller.

When the burner switches on and off, slight sounds could be heard due to settling of the structure. Do not worry about this as expansions are foreseen during design.

3.29 - ADJUSTING THE BURNER



The following instructions are intended exclusively for **service personnel authorised by the manufacturer of the burner.**

Burner calibration and preliminary operations are provided in the burner's instruction booklet.

Gas-fired burners are equipped with a gas valve with which the flow rate can be determined: upon commissioning, **the actual** thermal flow rate must always be controlled by means of the counter on the main piping, making sure it is not below the minimum value on the data plate of the boiler.

When the burner is adjusted properly, the values measured on the chimney by the specific analyser should correspond to those on the table on page 11.

4

INSPECTIONS AND MAINTENANCE



Inspections and maintenance performed professionally and according to a regular schedule as well as the use of original spare parts are of the utmost importance for fault-free operation of the boiler and to guarantee its long life. Yearly maintenance of the appliance is mandatory in compliance with Laws in force.



Failure to perform Inspections and Maintenance can entail material and personal damage.

We therefore recommend stipulating an inspection or maintenance contract.

Inspections help to determine the actual status of the appliance and to compare it with the nominal status. This is done through measuring, controls and observation.

Maintenance is required to eliminate any differences between the actual status and the nominal status. This is normally done by cleaning, setting and replacing individual components subject to wear.

Maintenance intervals and their extent are determined by a specialist based on the status of the appliance ascertained through inspection.

Inspection and maintenance instructions



To assure long-term functioning of your appliance and to avoid altering its approved status, only original Unical spare parts must be used.

Before proceeding with maintenance, always perform the following operations:

- Disconnect the electric mains switch.
- Isolate the appliance from the electric mains by means of an isolated device with a contact opening of at least 3 mm (e.g. safety devices or power switches) and make sure that it cannot be re-connected accidentally.
- Close the gas shut-off valve upstream the boiler.
- Close any shut-off valves on the heating flow and return pipes.

After having completed all maintenance work, always perform the following operations:

- Open the heating flow and return pipes.
- If necessary, restore the heating system pressure until it reaches the static pressure relative to the highest point of the system.
- Open the gas shut-off valve.
- Reconnect the appliance to the electric mains and engage the switch.
- Make sure the appliance is gas tight and watertight.
- Vent the heating system and restore pressure if necessary.

Should you decide to temporarily deactivate the boiler, you must:

- a) shut off the various supplies: electric, water and fuel;
- b) empty the water system if antifreeze is not used.

Inspections and maintenance

Boiler body maintenance



Danger!
Before performing any maintenance, make sure the boiler and its components have cooled off.

Disconnect the boiler from the electric mains and shut the gas supply to the appliance.



Attention!
Before cleaning the boiler body, protect the panel board against any water sprays.

Once a year, at the end of the heating season, the boiler must receive a general cleaning.

Before performing any maintenance, make sure that all the precautions referred to in the previous point have been taken. To proceed with maintenance you must:

- disconnect power by acting on the main switch;
- remove the burner, which could be overhauled at the same time;
- open the furnace door to access the combustion chamber;
- make sure the internal parts are intact.

Checking gasket status



Check the status of the seal gaskets which must not show signs of deterioration; if so, they must be replaced, using only original spare parts.

Maintenance of burner

Burner maintenance must be carried out by personnel authorised by its manufacturer (or else the warranty shall be terminated).

Checking ignition electrode

Burner maintenance must be carried out by personnel authorised by its manufacturer (or else the warranty shall be terminated).

Components to check during yearly inspection

COMPONENT:	VERIFY:	CONTROL/INTERVENTION MEASURE:
Safety thermostat	Does the thermostat place the boiler in safety when overheating?	Bring the boiler to operating temperature with the pumps stopped.
System expansion vessel	Does the vessel contain the right amount of air?	Check the nitrogen pressure. Pressurise the boiler (open the pump bleeder). Open the heating circuit closing valves.
Door gaskets	Does smoke seep through the door gaskets?	Further tighten the door nuts. Replace the sealing gasket.
Smoke chamber gaskets	Does smoke seep through the smoke chamber gaskets?	Further tighten the smoke chamber nuts. Replace the sealing gaskets.

■ ***Inspections and maintenance***

Unical[®] AG S.P.A.

46033 Casteldario - Mantova - ITALIA - tel. ++39.0376.57001 - telefax ++39.0376.660556
www.unical.eu info@unical-ag.com

Unical will not be held responsible for possible inaccuracies if due to transcription or printing errors. It also reserves the right to modify its products as deemed necessary or useful, without jeopardising their essential features.