



TMW-ST sensors are used for measuring the temperature of heating and cooling water networks.

Type code	Meas. element	Meas. accuracy
TMW-121ST, TMW-201ST / NTC10	NTC10	± 0,2 °C (0-70 °C)
TMW-121ST, TMW-201ST / Pt1000	Pt1000	± 1 °C (0-70 °C)
TMW-121ST, TMW-201ST / Ni1000	Ni1000 LG	± 1 °C (0-70 °C)

Technical information

Materials

- Case	Cover PC, base PBT, seal PA
- Immersion pipe	HST
- Nipple	MS 362 (SKM)
Range of use	-50 °C...+130 °C

Protection class

(water, cooling liquids and aggressive water. Not suitable for water having a high chlorine content)

Seal

IP 54

Pressure class

M16 x 1,5

Time constant

PN 16

Thread

< 5 s

Wrench size

R 1/2"

Dimensions:

21 mm

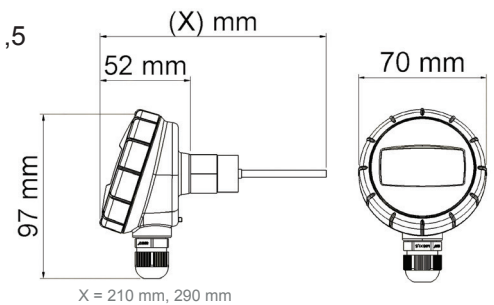

TMW-121ST:

Immersion sensor and 120 mm protection tube

ST-121:

120 mm protection tube

TMW-121:

The immersion sensor for a 120 mm protection tube

TMW-201ST:

Immersion sensor and 200 mm protection tube

ST-201:

200 mm protection tube

TMW-201:

The immersion sensor for a 200 mm protection tube

Installation and connection

Install the water sensor on the bend of the water-supply pipe so that the immersion sensor faces opposite the direction of flow.

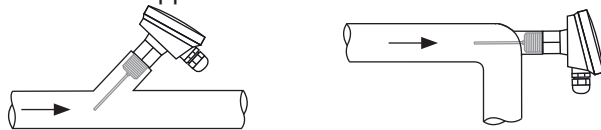

The sensor should be positioned at a place where the water is well mixed. With heating control install the supply water sensor approx. 1 m from the mixing point.

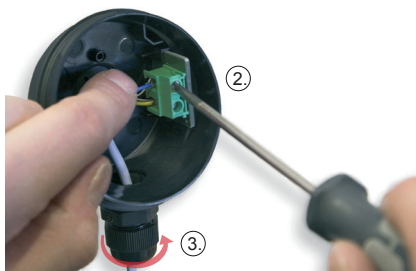

1. Screw the protective pocket on a welded pipe fitting or T-piece using proper sealing methods. Put the sensor in the protective sleeve so that the cable's bushing seal on the case goes down. Tighten the screw between the sensor and protective pocket.
2. Open the screw-off lid and connect the sensor to the controlling device as a two-wire connection using weak current cable. the polarity of the cable is irrelevant.
3. Tighten the bushing seal so that it acts as a seal and repels water.

NTC10

Tol. $\pm 0,2$ °C (0-70 °C)

Temperature/Resistance

°C	Ω
-50	672 600
-40	337 270
-30	177 210
-25	130 540
-20	97 140
-15	72 990
-10	55 350
-5	42 340
0	32 660
5	25 400
10	19 900
15	15 710
20	12 490
25	10 000
30	8 055
35	6 531
40	5 325
45	4 368
50	3 602
55	2 987
60	2 488
65	2 084
70	1 753
75	1 482
80	1 257
85	1 072
90	917,4
95	788,2
100	679,8
110	511,0
120	389,4
130	300,5
140	234,7

Ni 1000 LG

Tol. $\pm 0,4$ °C (0 °C)
DIN EN43760
tcr 5000 ppm / K

Temperature/Resistance

°C	Ω
-50	790,9
-40	830,8
-30	871,7
-25	892,5
-20	913,5
-15	934,7
-10	956,2
-5	978,0
0	1000,0
5	1022,3
10	1044,8
15	1067,6
20	1090,7
25	1114,0
30	1137,6
35	1161,5
40	1185,7
45	1210,2
50	1235,0
55	1260,1
60	1285,4
65	1311,1
70	1337,1
75	1363,5
80	1390,1
85	1417,1
90	1444,4
95	1472,0
100	1500,0
110	1557,0
120	1615,4
130	1675,2
140	1736,5

Pt 1000

Tol. $\pm 0,3$ °C (0 °C)
DIN EN60751 B
tcr 3850 ppm / K

Temperature/Resistance

°C	Ω
-50	803,1
-40	842,7
-30	882,2
-25	901,9
-20	921,6
-15	941,2
-10	960,9
-5	980,4
0	1000,0
5	1019,5
10	1039,0
15	1058,5
20	1077,9
25	1097,3
30	1116,7
35	1136,1
40	1155,4
45	1174,7
50	1194,0
55	1213,2
60	1232,4
65	1251,6
70	1270,8
75	1289,9
80	1309,0
85	1328,0
90	1347,1
95	1366,1
100	1385,1
110	1422,9
120	1460,7
130	1498,3
140	1535,8

2 x 0,5 mm² (Cu)

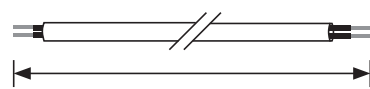

50 m	100 m
3,36 Ω	6,72 Ω

ΔT [K] Tolerance Ni 1000 LG

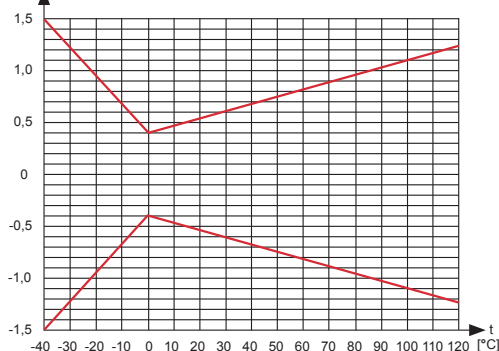

ΔT [K] Tolerance Pt 1000

