

Data sheet

Analog inputs 2 x 4...20 mA / 0...10 V

MULTICAL® 603

MULTICAL® 803

- Two analog inputs, selectable as 4...20 mA / 0...10 V
- Individual scaling of measuring ranges
- Individual setup of measuring unit and decimal point
- Selectable update interval from 1 second to 1 hour
- An external 24 VAC/VDC supply for the sensors is required



Contents

Description	2
Cable connections	3
Technical data	4
Ordering	4
Configuration	5
Display readings	6

Description

HC-003-41 is an all-round analog input module for use in the MULTICAL® 603 and MULTICAL® 803 energy meters. The analog signals can come from sensors, which are often used in industry, or from sensors that are used in building automation, e.g. temperature, pressure, air velocity, air energy content and air humidity sensors. Typically, sensors emit 4...20 mA or 0...10 V signals. The module writes the values of the analog signals to the P1 and P2 registers of the meter. The analog signals can be read from the meter display, and at the same time, they are logged in the memory of the meter. The analog signals can also be remotely read via the many various communication modules that are available for MULTICAL® 603 and MULTICAL® 803. In addition to the scaling of the min. value, max value and decimal position of the signal inputs, various measuring units can also be allocated, e.g. bar, m/s, %RH, etc. The reading speed of the analog inputs can be selected between a number of intervals ranging from 1 second to 1 hour. A quick reading enables the analog signals to be used for control and regulation purposes. The analog inputs are galvanically sepa-

rated from the meter. The module supplies the connected sensors via an isolated power supply, which also supplies the module itself.

Applications

The module can be used at places where there is a need for connecting 1 or 2 external sensors and where you want to read their measuring values in the meter display or remotely read the values via wired communication modules such as M-Bus, Modbus, BACnet and LON or wirelessly via wireless M-Bus and Kamstrup Low Power Radio and Kamstrup High Power RadioRouter.

Installation

The module is installed in the meter's module slot. If there is a need for adjusting the module's configuration, this can be done by using METERTOOL HCW via the optical read-out head or by using a module programming cable.

Note: There can only be 1 analog input module in the meter.

Cable connections

Terminals

Max cable size 1.5 mm²



Analog inputs

Terminal 60: + supply In 1, In 2

Terminal 58: Signal In 1

Terminal 59: Signal In 2

Terminal 57: - supply In 1, In 2

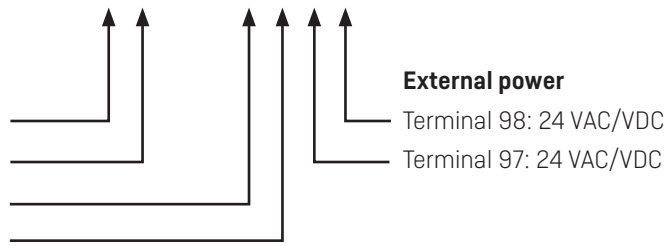

Examples of connection of sensors to input 1.

Depending on sensor type, there may be a difference in how to connect them to the terminals of the module.

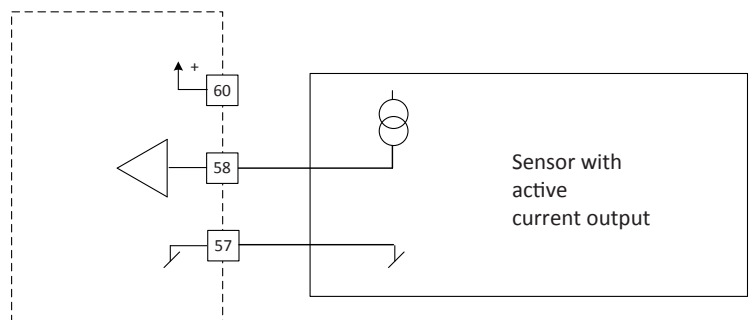
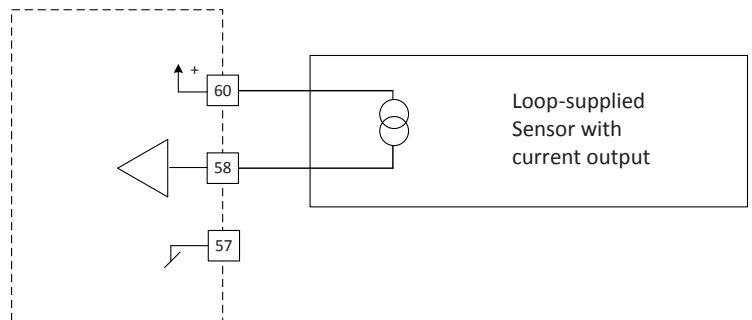
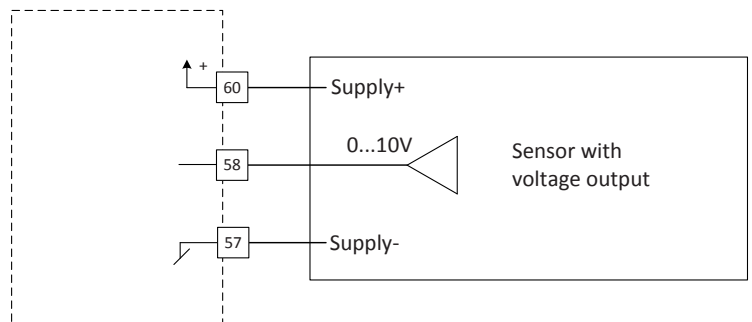

Technical data

Physical

For installation in MULTICAL® 603 and MULTICAL® 803.

Mechanical data

Dimensions [L x W x D] 90 x 35 x 14 mm
Weight < 45g.

MULTICAL® Supply

 AC supply

Analog inputs

Measuring ranges 4...20 mA / 0...10 V
Measuring accuracy < 0.1 %
Supply voltage In 1, In 2 15 VDC ±5 %
Current for In 1, In 2 ≤ 50 mA
Galvanic isolation > 2kV

External power

Voltage 24 VAC/VDC ±30 %
Recommended current ≥ 100 mA

Environment

Operational temperature 5 °C – 55 °C
Humidity 25 – 85 % RH non-condensing

Markings/approvals

CE, MID together with the type approval of MULTICAL® 603 and MULTICAL® 803.

Programming

Configuration/Firmware Via the optical readout head or the multipole connector on the module using METERTOOL HCW

Ordering

Order no.

HC-003-41
6699-403
6699-035
6699 -099
www.kamstrup.com

Description

Analog inputs 2 x 4...20 mA / 0...10 V
Transformer 230/24 VAC
USB configuration cable for H/C modules
Infrared optical readout head w/USB A plug
METERTOOL HCW

Configuration

Configuration of the module can be done when ordering or via METERTOOL HCW.

	XX	YY	ZZZ
Module type			
Analog inputs 2 x 4...20 mA / 0...10 V	41	00	100
Input 1 and Input 2 signal type			
4...20 mA		00	
0...10 V		10	

Parameters

The following parameters can be adapted to input 1 and input 2:

0 % value

The value of the signal when the current is 4 mA or the voltage is 0 V

100 % value

The value of the signal when the current is 20 mA or the voltage is 10 V

Decimal

It is possible to select between 3, 2, 1 or none decimals

Measuring unit

The following units are selectable:

Measuring unit	Description
Bar	Pressure
°C	Temperature
%RH	Relative humidity
g/kg	Absolute humidity
O ₂ %	Oxygen %
m/s	Velocity (air)
kJ/kg	Enthalpy, energy content of air
pH	pH, acidity
none	Numeric value

Reading speed

It is possible to choose between the following intervals, which are common to both inputs:





1 second	2 minutes
2 seconds	5 minutes
5 seconds	10 minutes
10 seconds	15 minutes
15 seconds	30 minutes
30 seconds	60 minutes
60 seconds	

Display readings

Current values

The current values can be read from the energy meter's display by choosing the TECH-loop.

Display examples:

Menu	Menu index	Information	Display example
2-004-2	P1	Current value of input 1 Example: Pressure with 2 decimals	
2-004-2	P1	Current value of input 1 Example: Temperature with 1 decimal	
2-005-2	P2	Current value of input 2 Example: O ₂ % with 2 decimals Note that unit is not displayed.	
2-005-2	P2	Current value of input 2 Example: pH with 3 decimals Note that unit is not displayed.	

Display readings

Module information

The module information can be read by choosing the TECH-loop on the MULTICAL® meter.



Module placed in module slot 1: Choose menu 2-101 in the TECH-loop

Module placed in module slot 2: Choose menu 2-201 in the TECH-loop

Module placed in module slot 3: Choose menu 2-301 in the TECH-loop

Module placed in module slot 4: Choose menu 2-401 in the TECH-loop

The following module information is available:

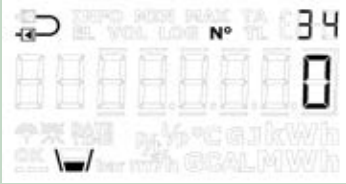
Menu	Menu index	Information	Display example
2-x01	31	Module configuration	
2-x01-1	32	Module firmware and revision	
2-x01-2	33	Module serial number	
2-x01-3	49	Module status * 0: Ok 1: No configuration 2: Internal error 4: No 24 V supply	

* There are 3 sources of errors that are weighted with each of their values. The sum of these 3 error values is shown in Module status. If Module status shows other values than 0 and 4, the module must be sent in for repair.

Analog inputs 2 x 4...20 mA / 0...10 V

MULTICAL® 603
MULTICAL® 803

Kamstrup A/S

Industrivej 28, Stilling
DK-8660 Skanderborg
T: +45 89 93 10 00
F: +45 89 93 10 01
info@kamstrup.com
kamstrup.com